



USER GUIDE & INSTALLATION INSTRUCTIONS

Professional+ / Classic FX 90 Dual Fuel

U111274-03b

Contents

1. Before you start...	1	5. Cooking tips	18
Personal safety	1	6. Cooking table	19
Electrical connection safety	2	7. Cleaning your cooker	20
If you smell gas	3	8. Troubleshooting	23
Peculiar smells	3	9. Installation	25
Cooling fan	3	Location of cooker	25
Ventilation	3	Positioning the cooker	28
Maintenance	3	Moving the cooker	28
Cooker care	5	Lowering the two rear rollers	28
Cleaning	6	Completing the move	29
2. Overview	7	Levelling	29
Hotplate burners	8	Fitting the stability bracket or chain	29
Wok burner	9	Repositioning the cooker following connection	29
Wok cradle	9	Gas connection	30
Griddle	9	Electrical connection	31
Multifunction oven	10	10. Final checks and fittings	32
Energy saving panel	12	Fitting the drawer	33
Operating the oven	12	Removing the drawer	33
Accessories	13	11. Circuit diagram	34
3. Rotary clock	14	12. Technical data	35
4. 3 button clock	16		

1. Before you start...

Your cooker should give you many years of trouble-free cooking if installed and operated correctly. It is important that you read this section before you start.

This User Guide covers a number of different models. Although some of the illustrations will look different to your particular model the functions will be the same. We hope the meaning is clear.

Personal safety

This appliance is for cooking purposes only. It must not be used for other purposes, for example heating a room. Using it for any other purpose could invalidate any warranty or liability claim. Besides invalidating claims this wastes fuel and may overheat the control knobs.

This cooker must be installed in accordance with the relevant instructions in this booklet and with the national and local regulations as well as the local gas and electricity supply companies' requirements.

- This appliance can be used by children aged from 8 years and above and persons with reduced physical, sensory or mental capabilities or lack of experience and knowledge if they have been given supervision or instruction concerning use of the appliance in a safe way and understand the hazards involved.
- **WARNING:** Children **less** than 8 years of age should be kept away unless continuously supervised. Children shall not play with the appliance. Cleaning and user maintenance shall not be made by children without supervision.
- The cooker should not be placed on a base.
- This appliance is designed for domestic cooking only. Use for any other purpose could invalidate any warranty or liability claim.
- Before operating the oven(s) please refer to the oven shelf installation, in the Accessories section.
- **WARNING:** The appliance and its accessible parts become hot during use and will retain heat even after you have stopped cooking. Care should be taken to avoid touching heating elements. Children less than 8 years of age shall be kept away unless continuously supervised.
- **CAUTION:** A long term cooking process has to be supervised from time to time. A short term cooking process has to be supervised continuously.
- At the risk of fire **DO NOT** store items on the cooking surfaces.
- To avoid overheating, **DO NOT** install the cooker behind a decorative door.
- **WARNING:** Accessible parts will become hot during use and will retain heat even after you have stopped cooking. Keep babies and children away from the cooker and never wear loose-fitting or hanging clothes when using the appliance.
- **DO NOT** use a steam cleaner on your cooker.
- Always keep combustible materials, e.g. curtains, and flammable liquids a safe distance away from the cooker.
- **DO NOT** spray aerosols in the vicinity of the cooker while it is on.

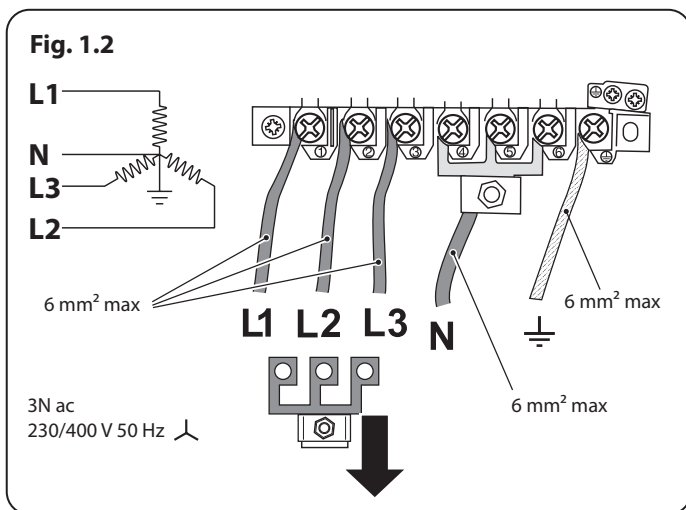
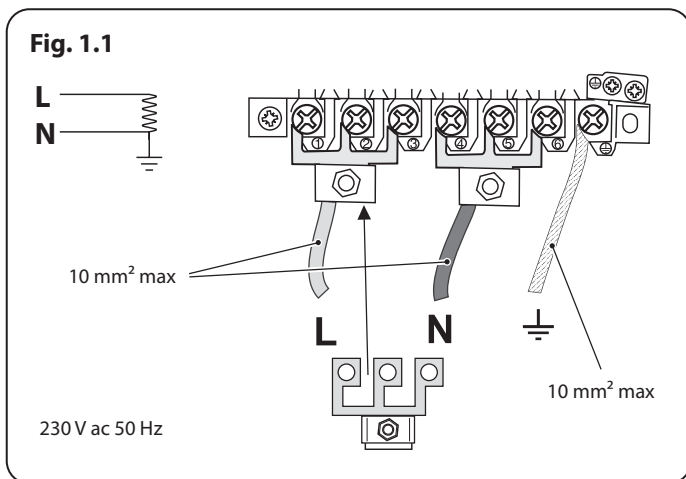

Electrical connection safety

⚠ WARNING: THE APPLIANCE MUST BE EARTHED.

Note: The cooker must be connected to the correct electrical supply as stated on the voltage label on the cooker, through a suitable cooker control unit incorporating a double-pole switch, having a contact separation of at least 3 mm in all poles.

⚠ The cooker MUST NOT be connected to an ordinary domestic power point.

Access to the mains terminal is gained by removing the electrical terminal cover box on the back panel. Connect the mains cable to the correct terminals for your electrical supply type (**Fig. 1.1** and **Fig. 1.2**). Check that the links are correctly fitted and that the terminal screws are tight. Secure the mains cable using the cable clamp.

Minimum temperature rating T105.

Read the instructions before installing or using this appliance.

Gas connection safety

- This cooker is a Class 2 Subclass 1 appliance.
- This appliance can be converted for use on another gas.
- Before installation, make sure that the cooker is suitable for your gas type and supply voltage. See the data badge.
- **DO NOT** use reconditioned or unauthorised gas controls.
- Disconnect from the electricity and gas supply before servicing.
- When servicing or replacing gas-carrying components disconnect from the gas supply before starting operation. Check the appliance is gas sound after completion.

- Make sure that the gas supply is turned on and that the cooker is wired in and switched on.
- In your own interest and that of safety, it is law that all gas appliances be installed by a qualified person(s).
- An appliance for use on LPG must not be installed in a room or internal space below ground level, e.g. in a basement.

If you smell gas

- **DO NOT** turn electric switches on or off
- **DO NOT** smoke
- **DO NOT** use naked flames
- Turn off the gas at the meter or cylinder
- Open doors and windows to get rid of the gas
- Keep people away from the area affected
- Call your gas supplier

Peculiar smells

When you first use your cooker it may give off an odour. This should stop after use.

Before using for the first time, make sure that all packing materials have been removed and then, to dispel manufacturing odours, turn the ovens to 200 °C and run for at least an hour.

Make sure the room is well ventilated to the outside air (see 'Ventilation' below). People with respiratory or allergy problems should vacate the area for this brief period.

Cooling fan

This appliance has a cooling fan. When the oven is in operation the fan will run to cool the fascia and control knobs.

Ventilation

The use of a cooking appliance results in the production of heat and moisture in the room in which it is installed. Therefore, make sure that the kitchen is well ventilated: keep natural ventilation holes open or install a powered cookerhood that vents outside. If you have several hotplates/burners on, or use the cooker for a long time, open a window or turn on an extractor fan

Maintenance

- It is recommended that this appliance is serviced annually.
- **WARNING:** Before removing the existing bulb, turn off the power supply and make sure that the oven and bulb have cooled.
- **DO NOT** use cooking vessels on the hotplate that overlap the edges.
- Unless specified otherwise in this guide, always allow the cooker to cool and then switch it off at the mains before cleaning or carrying out any maintenance work.
- **DO NOT** use the control knobs to manoeuvre the cooker.
- **NEVER** operate the cooker with wet hands.
- **DO NOT** use a towel or other bulky cloth in place of a glove – it might catch fire if brought into contact with a hot surface.
- **DO NOT** use hotplate protectors, foil or hotplate covers of any description. These may affect the safe use of your hotplate burners and are potentially hazardous to health.
- **NEVER** heat unopened food containers. Pressure build up may make the containers burst and cause injury.
- **WARNING:** Use only hob guards designed by the manufacturer of the cooking appliance or indicated by the manufacturer of the appliance in the instructions for use

as suitable or hob guards incorporated in the appliance. The use of inappropriate guards can cause accidents.

- **DO NOT** use unstable saucepans. Always make sure that you position the handles away from the edge of the hotplate.
- **NEVER** leave the hotplate unattended at high heat settings. Pans boiling over can cause smoking, and greasy spills may catch on fire. Use a deep fat thermometer whenever possible to prevent fat overheating beyond the smoking point.

⚠ WARNING: Unattended cooking on a hob with fat or oil can be dangerous and may result in fire.

- **NEVER** try to extinguish a fire with water, but switch off the appliance and then cover the flame e.g. with a lid or a fire blank
- **NEVER** leave a chip pan unattended. Always heat fat slowly, and watch as it heats. Deep fry pans should be only one third full of fat.
- **WARNING: Danger of fire: do not store items on the cooking surfaces.**
- **NEVER** try to move a pan of hot fat, especially a deep fat fryer. Wait until the fat is cool. Filling the pan too full of fat can cause spill over when food is added. If you use a combination of oils or fats in frying, stir them together before heating, or as the fats melt.
- Foods for frying should be as dry as possible. Frost on frozen foods or moisture on fresh foods can cause hot fat to bubble up and over the sides of the pan. Carefully watch for spills or overheating of foods when frying at high or medium high temperatures.
- **DO NOT** use the top of the flue (the slot along the back of the cooker) for warming plates, dishes, drying tea towels or softening butter.

- **DO NOT** use water on grease fires and never pick up a flaming pan. Turn the controls off and then smother a flaming pan on a surface unit by covering the pan completely with a well fitting lid or baking tray. If available, use a multi-purpose dry chemical or foam-type fire extinguisher.
- **DO NOT** modify this appliance. This appliance is not intended to be operated by means of external timer or separated remote-control system.
- If flammable materials are stored in the drawer, oven(s) or grill(s) it may explode and result in fire or property damage.

Oven Care

- When the oven is not in use and before attempting to clean the cooker always be certain that the control knobs are in the **OFF** position.
- Use oven gloves to protect your hand from potential burns.
- Cooking high moisture content foods can create a 'steam burst' when the oven door is opened (**Fig. 1.3**). When opening the oven, stand well back and allow any steam to disperse.
- The inside door face is constructed with toughened safety glass. Take care **NOT** to scratch the surface when cleaning the glass panel.
- Accidental damage may cause the door glass panel to fracture.
- Keep oven vent ducts unobstructed.
- **DO NOT** use harsh abrasive cleaners or sharp metal scrapers to clean the oven door glass since they can scratch the surface, which may result in shattering of the glass.
- Make sure the shelves are pushed firmly to the back of the oven. **DO NOT** close the door against the oven shelves.

- **DO NOT** use aluminium foil to cover shelves, linings or the oven roof.
- When the oven is on, **DO NOT** leave the oven door open for longer than necessary, otherwise the control knobs may become very hot.
- **DO NOT** use the timed oven if the adjoining oven is already warm.
- **DO NOT** place warm food in the oven to be timed.
- **DO NOT** use a timed oven that is already warm.
- Use dry oven gloves when applicable – using damp gloves might result in steam burns when you touch a hot surface.

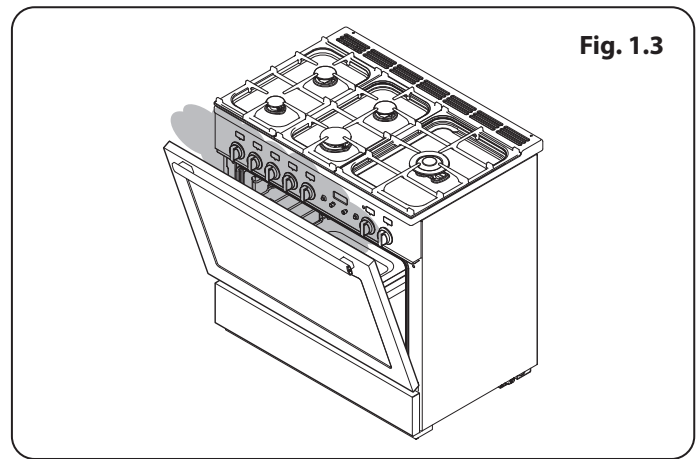

Fig. 1.3

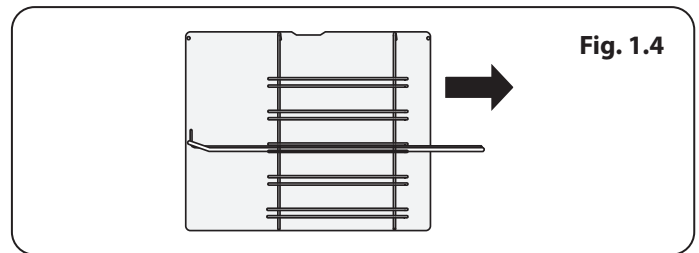

Fig. 1.4

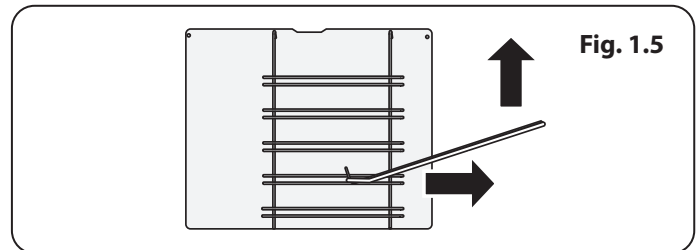

Fig. 1.5

Oven Shelves

To remove and refit the shelves. Pull the shelf forwards until the back of the shelf is stopped by the shelf support (**Fig. 1.4**). Lift up the front of the shelf so the back of the shelf will pass between the supports and then pull the shelf forward (**Fig. 1.5**).

Refit in the reverse order, making sure to push it fully back.

Cooker care

As steam can condense to water droplets on the cool outer trim of the oven, it may be necessary during cooking to wipe away any moisture with a soft cloth. This will also help to prevent soiling and discolouration of the oven exterior by cooking vapours.

Cleaning

- **WARNING:** Using the self-cleaning function results in higher temperatures than those for normal cooking. Under such conditions the surfaces may get hotter than usual so children should be kept away.
- Isolate the electricity supply before carrying out any thorough cleaning. Allow the cooker to cool.
- In the interests of hygiene and safety, the cooker should be kept clean at all times as a build up in fats and other food stuff could result in a fire.
- Clean only the parts listed in this guide.
- Clean with caution. If a wet sponge or cloth is used to wipe spills on a hot surface, be careful to avoid steam burns. Some cleaners can produce noxious fumes if applied to a hot surface.
- Pre-clean any areas that are not reached by the self-clean cycle, such as the outer edges of the oven door. Wipe up any excess fat or liquids.
- Remove all cookware, shelves and the shelf supports from the oven before using the self-clean function.
- **NEVER** use paint solvents, washing soda, caustic cleaners, biological powders, bleach, chlorine based bleach cleaners, coarse abrasives or salt.
- **DO NOT** mix different cleaning products – they may react together with hazardous results.
- All parts of the cooker can be cleaned with hot soapy water.
- Take care that no water seeps into the appliance.
- Before you remove any of the grill parts for cleaning, make sure that they are cool or use oven gloves.
- **DO NOT** use any abrasive substances on the grill and grill parts.
- **DO NOT** put the side runners in a dishwasher.
- **DO NOT** put the burner heads in a dishwasher.
- **NEVER** use caustic or abrasive cleaners as these will damage the surface.
- **DO NOT** use steel wool, oven cleaning pads or any other materials that will scratch the surface.
- **NEVER** store flammable materials in the drawer. This includes paper, plastic and cloth items, such as cookbooks, plastic ware and towels, as well as flammable liquids.
- **DO NOT** store explosives, such as aerosol cans, on or near the appliance.
- **DO NOT** use steel wool, oven cleaning pads, or any other materials that will scratch the surface.
- **DO NOT** attempt to disassemble or clean around any burner while another burner is on, otherwise an electric shock could result.

2. Overview

Fig. 2.1

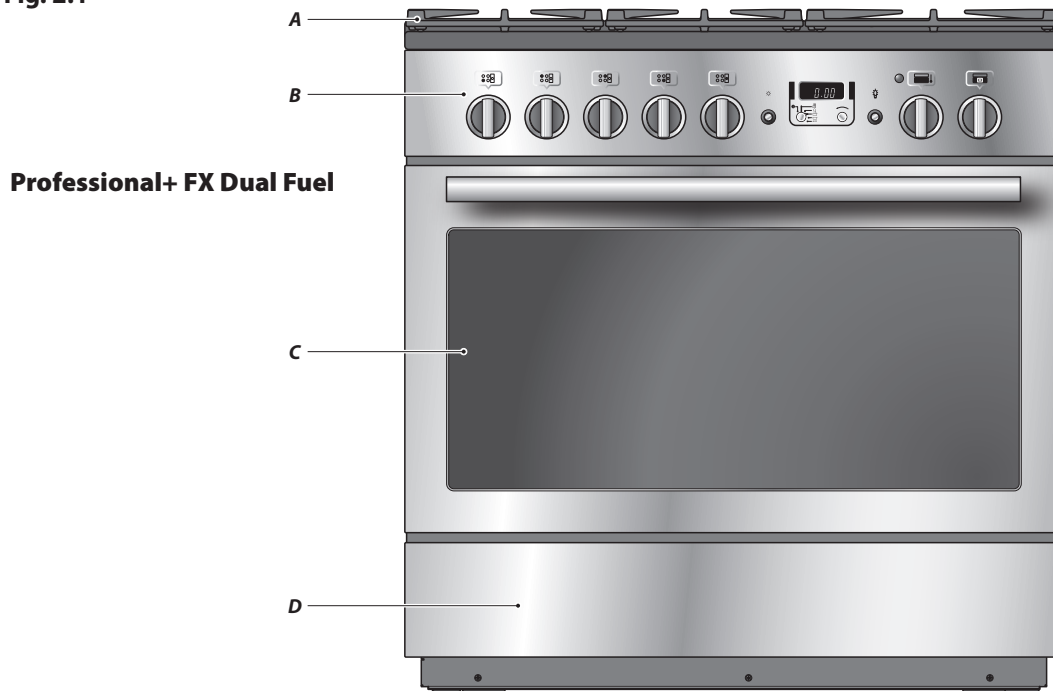
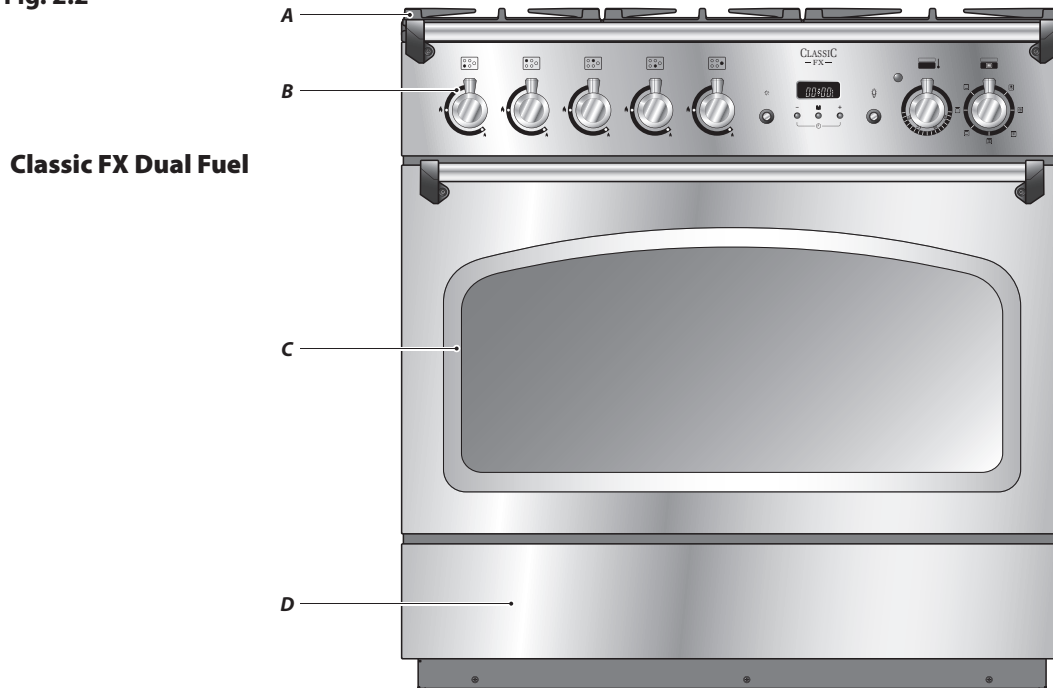

Fig. 2.2



The dual fuel single cavity cookers have the following features:

- A. 5 hotplate burners including a wok burner
- B. Control panel incorporating a timer
- C. Multifunction oven
- D. Storage drawer

Hotplate burners

The drawing by each of the central knobs indicates which burner that knob controls.

Each burner has a Flame Supervision Device (FSD) that prevents the flow of gas if the flame goes out.

When the igniter button is pressed in, sparks will be made at every burner – this is normal. Do not attempt to disassemble or clean around any burner while another burner is on, otherwise an electric shock could result.

To light a burner, press the igniter button, and push in and turn the associated control knob to the high position as indicated by the large flame symbol (🔥), (Fig. 2.3).

The igniter should spark and light the gas. Keep holding the knob pressed in to let the gas through to the burner for about ten seconds.

If, when you let go of the control knob, the burner goes out, then the FSD has not been bypassed. Turn the control knob to the OFF position and wait for one minute before you try again, this time making sure to hold in the control knob for slightly longer.

Adjust the flame height to suit by turning the control knob counter-clockwise (Fig. 2.4).

If a burner flame goes out, turn off the control knob and leave it for one minute before relighting it.

Make sure that the flames are under the pans. For safety reasons, adjust the flames so that they do not extend beyond the edge of the cooking utensil. Using a lid will help the contents boil more quickly (Fig. 2.5).

Large pans should be spaced well apart.

Pans and kettles with concave bases or down-turned base rims should not be used (Fig. 2.6).

Simmering aids, such as asbestos or mesh mats, are NOT recommended (Fig. 2.7). They will reduce burner performance and could damage the pan supports.

You should also avoid using unstable and misshapen pans that may tilt easily, and pans with a very small base diameter, e.g. milk pans, single egg poachers (Fig. 2.8).

The minimum recommended pan diameter is 120 mm. The maximum allowable pan base diameter is 260 mm.

DO NOT use cooking vessels on the hotplate that overlap the edges.

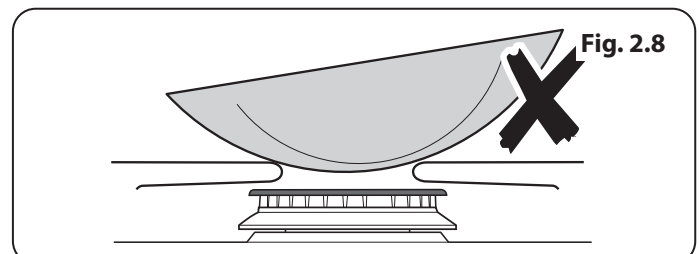
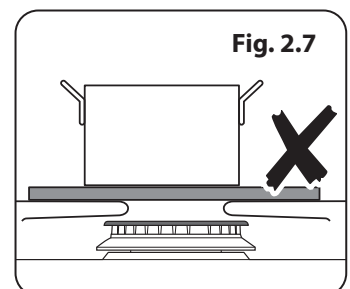
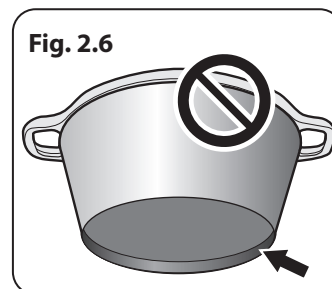
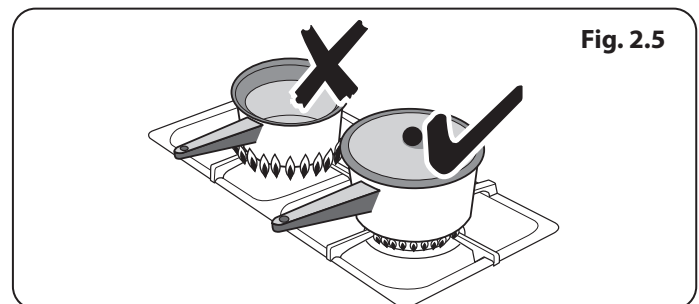
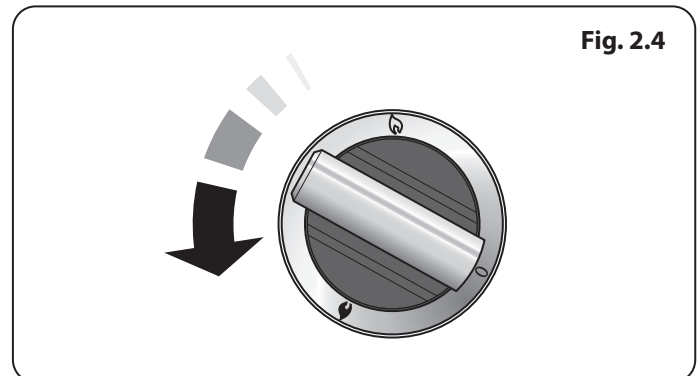
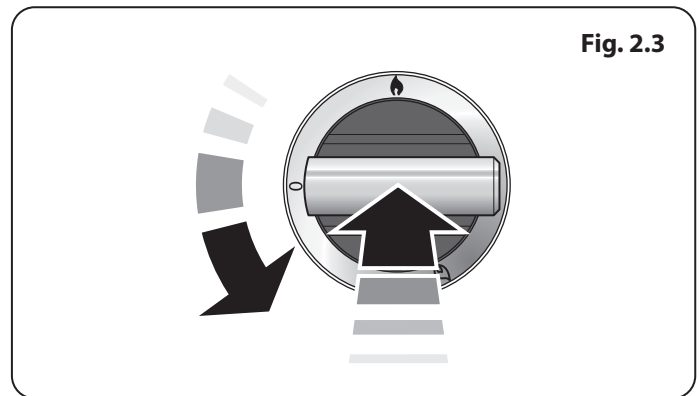
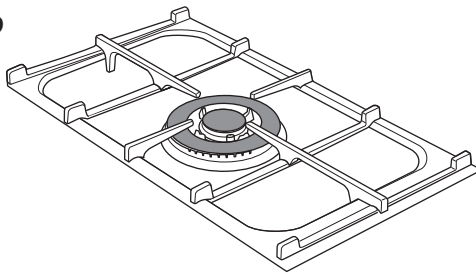

Fig. 2.9



Wok burner

The wok burner is designed to provide even heat over a large area. It is ideal for large pans and stir-frying (**Fig. 2.9**).

For heating smaller pans, the aforementioned hotplate burners may be more efficient.

You should wipe the enamel top surface of the cooker around the hotplate burners as soon as possible after spills occur. Try to wipe them off while the enamel is still warm.

Note: The use of aluminium pans may cause metallic marking of the pan supports. This does not affect the durability of the enamel and may be cleaned off with an appropriate metal cleaner.

Fig. 2.10

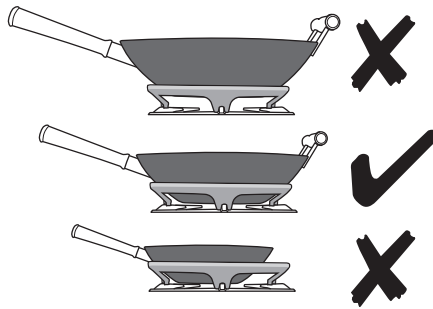

Wok cradle

The wok cradle is designed to fit a 35 cm wok. If you use a different wok, make sure that it fits the cradle. Woks vary very widely in size and shape. It is important that the wok sits down on the pan support – however, if the wok is too small, the cradle will not support it properly (**Fig. 2.10**).

The cradle should be used on the wok burner only. When you fit the cradle, check that it is properly located and that the wok is supported properly on a pan support (**Fig. 2.11**).

The cradle will get very hot in use – allow plenty of time for it to cool before you pick it up.

Fig. 2.11

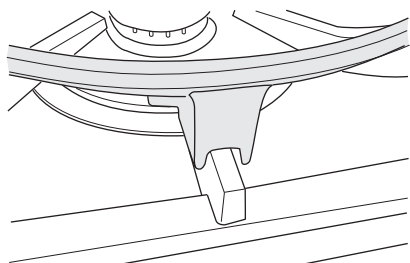
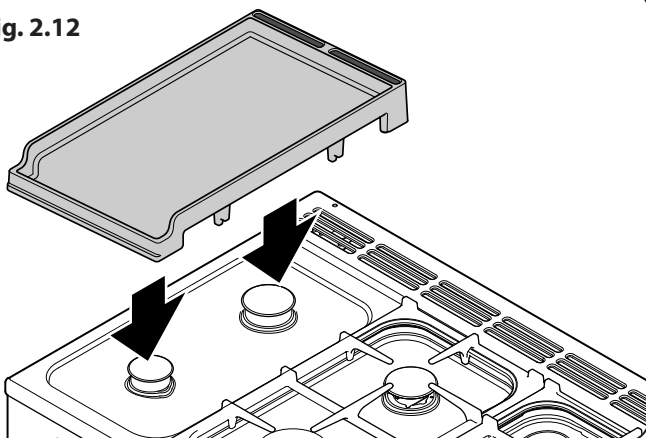

Fig. 2.12



Griddle

The griddle fits the left-hand well, front to back (**Fig. 2.12**). It is designed for cooking food on directly. **DO NOT** use pans of any kind on it. The griddle surface is non-stick and metal cooking utensils (e.g. spatulas) will damage the surface. Use heat resistant plastic or wooden utensils.

⚠ Do not put it crossways – it will not fit properly and will be unstable.

⚠ Do not put it on any other burner – it is not designed to fit in any of the other cooker wells.

Remove the left-hand pan support. Position the griddle over the well. Check that it is securely located.

The griddle can be lightly brushed with cooking oil before use. Light the hotplate burners. Adjust the flame heights to suit.

Preheat the griddle for a **maximum of 5 minutes** before adding food. Leaving it longer may cause damage. Turn the control knobs towards the low position, marked with the small flame symbol, to reduce the burner flames.

Always leave space around the griddle for the gases to escape.

After cooking, allow the griddle to cool before cleaning.

If the griddle is washed in a dishwasher then some dishwasher residue may appear on the back. This is normal and will not affect the performance of your griddle.

Fig. 2.13

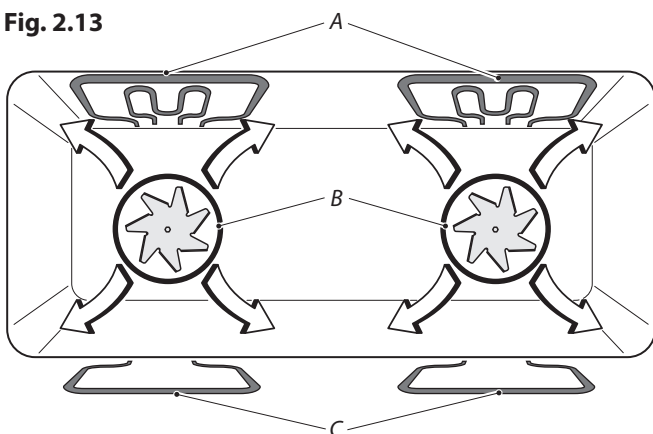

A – Grill elements, B – Convection element, C – Base heat elements

Multifunction oven

The oven is a multifunction oven (Fig. 2.13). In addition to convection elements around the fans, it is fitted with extra heating elements, in the top of the oven and under the oven base. Take care to avoid touching the top elements when placing or removing items from the oven.

The multi-function oven has 3 main cooking functions: **fan**, **fan assisted** and **conventional cooking**. These functions should be used to complete most of your cooking.

The **browning element** and **base heat** can be used in the latter part of the cooking process to fine tune the results to your particular requirements.

Use **fanned grilling** for all your grilling needs and **defrost** to safely thaw small items of frozen food.

Table 2.1 gives a summary of the multifunction modes.

The multifunction oven has many varied uses. We suggest you keep a careful eye on your cooking until you are familiar with each function. Remember, not all functions will be suitable for all food types.

Multifunction oven modes

(Fig. 2.14 Professional & Fig. 2.15 Classic)

Defrost



This function operates the fan(s) to circulate cold air only. Make sure the temperature control is at 0°C and that no heat is applied. This enables small items such as desserts, cream cakes and pieces of meat, fish and poultry to be defrosted.

Defrosting in this way speeds up the process and protects the food from contamination. Pieces of meat, fish and poultry should be placed on a shelf, over a tray to catch any drips. Be sure to wash the shelf and tray after defrosting.

Defrost with the oven door closed. Defrosting should not be carried out in a warm oven. Large items, such as whole chickens and meat roasts should not be defrosted in this way. We recommend this be carried out in a refrigerator.

Make sure that dairy foods, meat and poultry are completely defrosted before cooking.

Fan oven



This function operates the fans and the heating element around them. An even heat is produced throughout the oven, allowing you to cook large amounts quickly.

Fan oven cooking is particularly suitable for multi-shelf cooking and is a good 'all-round' function. It may be necessary to reduce the temperature by approximately 10°C for recipes previously cooked in a conventional oven.

If you wish to preheat the oven, wait until the indicator light has gone out before inserting the food.

Function	Use
Defrost	To thaw small items in the oven without heat
Fan oven	A full cooking function, even heat throughout, great for baking
Fanned grilling	Grilling meat and fish with the door closed
Fan assisted	A full cooking function good for roasting and baking
Conventional oven	A full cooking function for roasting and baking in the lower half of the oven
Browning element	To brown and crisp cheese topped dishes
Base heat	To crisp up the bases of quiche, pizza or pastry

Table 2.1

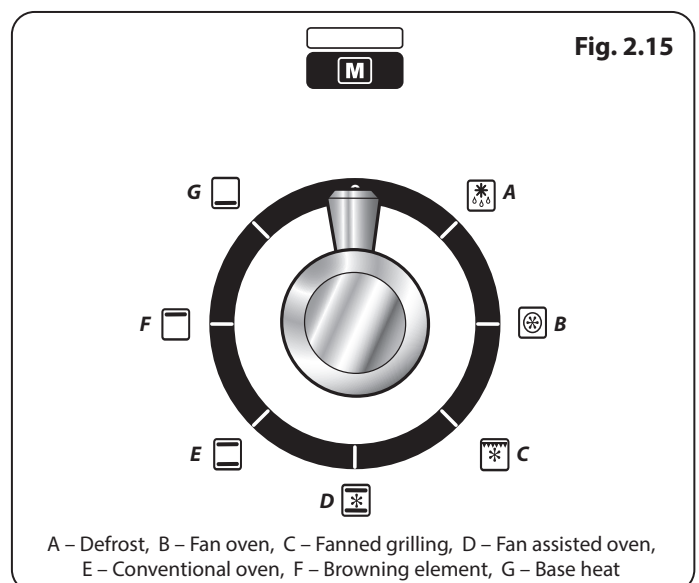
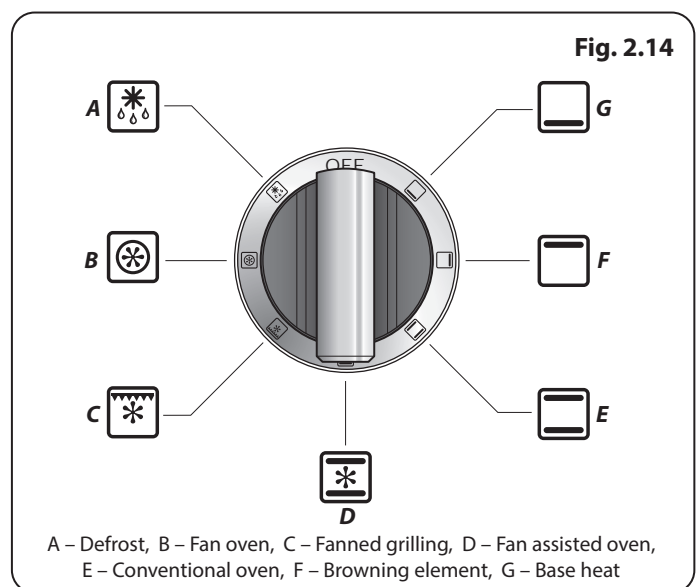

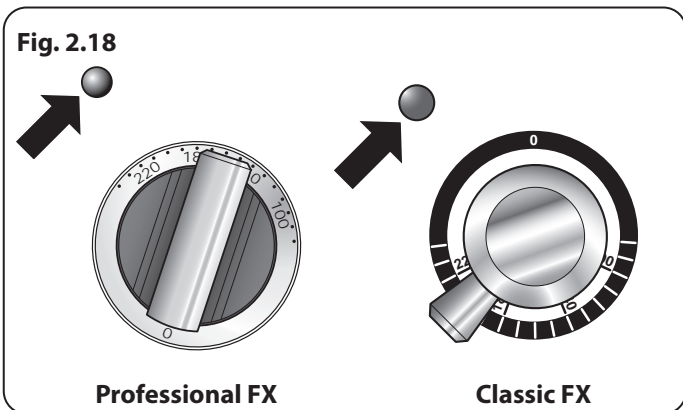
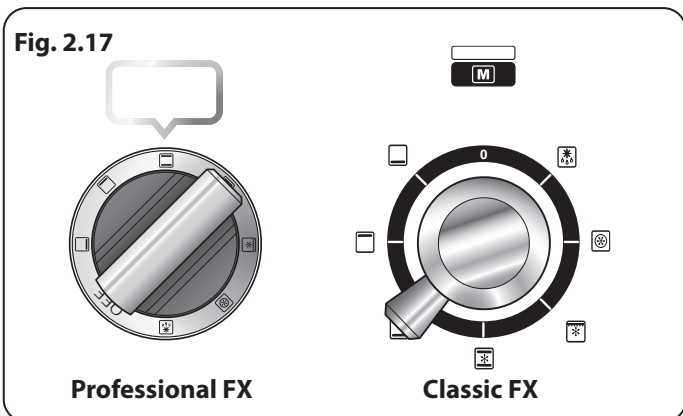
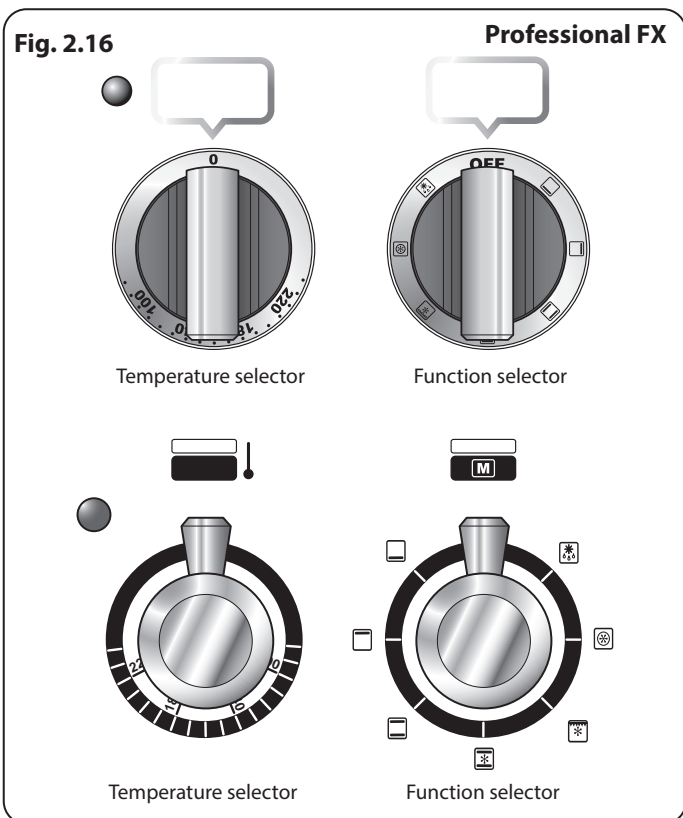

Fanned grilling



This function operates the fan while the top element is on. It produces a more even, less fierce heat than a conventional grill. For best results place the food to be grilled on the pan provided. Thick pieces of meat or fish are ideal for cooking in this way, as the circulated air reduces the fierceness of the heat from the grill. The oven door should be kept closed while cooking is in progress, so saving energy. You will also find that the food needs to be watched and turned less than for normal grilling. Preheat this function before cooking.

Note: When grilling full width, to allow sufficient access for tending foods we recommend placing the grill pan tray support on the second from top level.

Fan assisted oven



This function operates the fans, circulating air heated by the elements at the top and the base of the oven. The combination of fan and conventional cooking (Top and Base Heat) makes this function ideal for cooking large items that need thorough cooking, such as a large meat roast. It is also possible to bake on two shelves at one time, although they will need to be changed over during the cooking time, as the heat at the top of the oven is greater than at the base, when using this function.

This is a fast intensive form of cooking; keep an eye on the food cooking until you are familiar with this function.

Conventional oven (Top and Base Heat)



This function combines the heat from the top and base elements. It is particularly suitable for roasting and baking pastry, cakes and biscuits.

Food cooked on the top shelf will brown and crisp faster than on the lower shelf, because the heat is greater at the top of the oven than at the base, as in 'Fan Assisted Oven' function. Similar items being cooked will need to be swapped around for even cooking. This means that foods requiring different temperatures can be cooked together, using the cooler zone in the lower half of the oven and hotter area to the top.

The exposed top element may cook some foods too quickly, so we recommend that the food be positioned in the lower half of the oven to cook. The oven temperature may also need to be lowered.

Browning element



This function uses the element in the top of the oven only. It is a useful function for the browning or finishing of pasta dishes, vegetables in sauce and lasagne, the item to be browned being already hot before switching to the top element.

Base heat



This function uses the base element only. It will crisp up your pizza or quiche base or finish off cooking the base of a pastry case on a lower shelf. It is also a gentle heat, good for slow cooking of casseroles in the middle of the oven or for plate warming.

The Browning and Base Heat functions are useful additions to your oven, giving you flexibility to finish off items to perfection. With use, you will soon realise how these functions can combine to extend your cooking skills.

Operating the oven

The multifunction oven has two controls: a function selector and a temperature setting knob (Fig. 2.16).

Turn the function selector control to a cooking function. Fig. 2.17 shows the control set for convectional oven cooking.

Turn the oven temperature knob to the temperature you need. The oven heating light will glow until the oven has reached the temperature you selected. It will then cycle on and off during cooking as the oven maintains the selected temperature (Fig. 2.18).

Oven light

Press the button to turn on the oven lights (Fig. 2.19).

If one of the oven lights fail, turn off the cooker power supply before you change the bulb. See the 'Troubleshooting' section for details on how to change an oven light bulb.

Energy saving panel

The oven has a divider feature (Fig. 2.20). With this in place only one half of the oven is heated and only the right-hand side elements are used. This saves energy and is ideal for cooking most foods. When using the divider, condensation may appear in the left-hand oven – this is normal.

For very large loads, or large dishes for special occasions then the divider can be removed. This brings into use the elements on the left-hand side as well as those on the right when a function is selected.

All oven functions are available in full and divided forms and shelves are provided for use in both forms.

Warning!
Take great care when removing the divider not to scratch the inner glass door surface. Scratches in the glass can cause stress and may cause the door to fail.

Removing the divider

Warning!
Make sure the cooker is cool before attempting to remove the divider.

Fully open the door and remove the oven shelves. When removing the divider, tilt it slightly upwards and grip the underside to prevent the metal base making contact with the door glass (Fig. 2.21 and Fig. 2.22).

We recommend that you place a tea towel or similar on the door glass before removing the divider. This should prevent the door inner from scratching.

DO NOT place or slide metallic objects, including cookware, on the door glass as this may cause scratching and subsequent failure to occur.

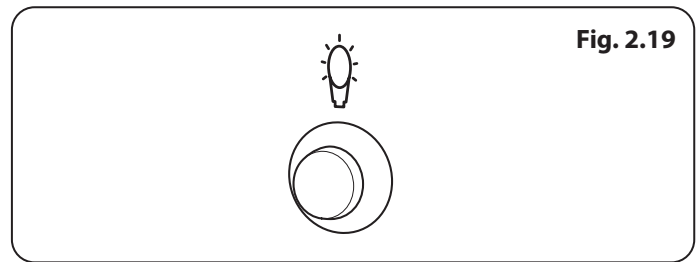

Fig. 2.19

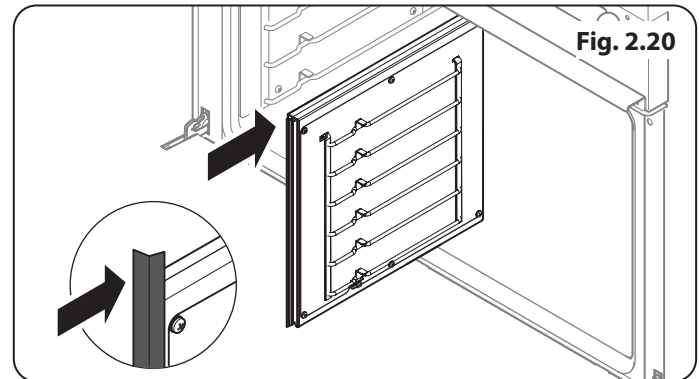

Fig. 2.20

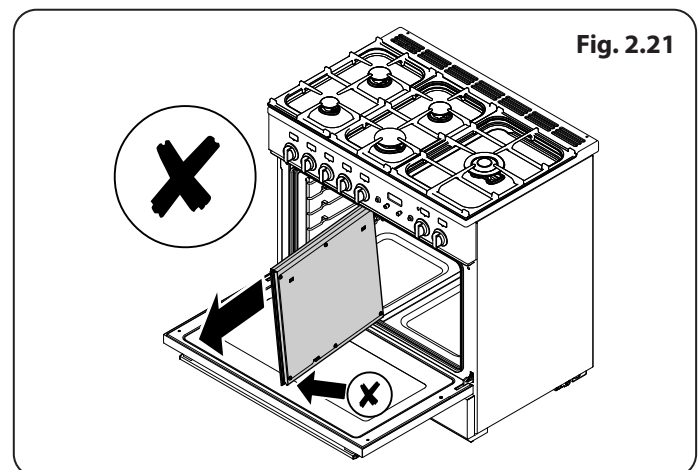

Fig. 2.21

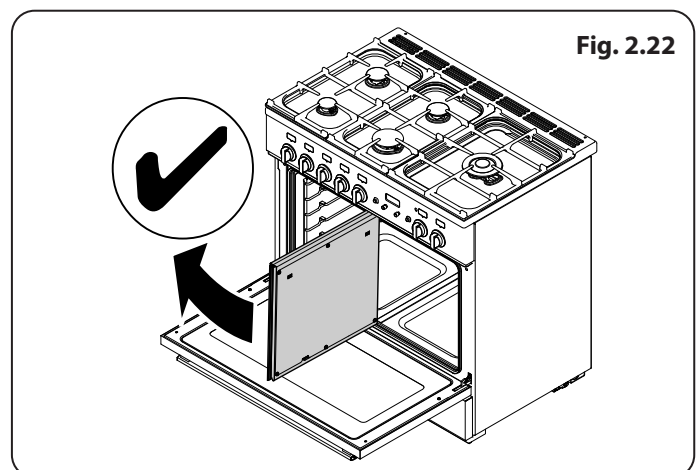
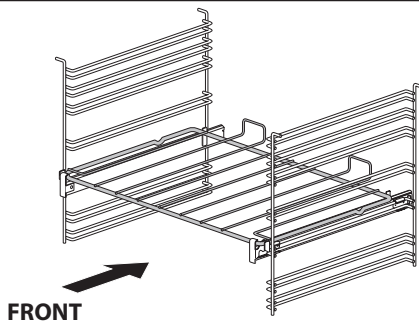

Fig. 2.22

Fig. 2.23



Accessories *refer to page 26*

Telescopic runners *(Left-hand oven)*

A glide-out oven shelf is available for the left-hand oven (**Fig. 2.23**).

Note: The Handyrack must be removed before fitting the glide-out shelf.

The rungs on the shelf supports are in pairs. The glide-out shelf runners can be fitted to any pair except the top.

To fit the glide-out shelf runners

Hook the rear of the runner over the top rung of a pair of shelf supports. Then hook the front of the runner onto the same rung. Push to clip under the bottom rung (**Fig. 2.24**).

The front of the shelf runners can be identified by the bracket (**Fig. 2.26**).

Ensure that the shelf runners are fitted in the same position on each side (**Fig. 2.25**).

To fit the glide-out shelf

Check the shelf runners are secure before fitting the glide-out shelf.

Hook the front of the glide-out oven shelf onto the runners as shown (**Fig. 2.26**). The rear of the shelf should rest on the runners, in front of the rear stop (**Fig. 2.26**).

Ensure that the shelf sits flat once in position.

⚠ DO NOT put the glide-out shelf runners in a dishwasher

Storage

The bottom drawer is for storing oven trays and other cooking utensils. The drawer can be removed completely for cleaning, etc.

⚠ It can get very warm, so do not store anything in it that may melt or catch fire.

⚠ Never store flammable materials in the drawer. This includes paper, plastic and cloth items, such as cookbooks, plastic ware and towels, as well as flammable liquids.

⚠ Do not store explosives, such as aerosol cans, on or near the appliance.

⚠ Flammable materials may explode and result in fire or property damage.

Fig. 2.24

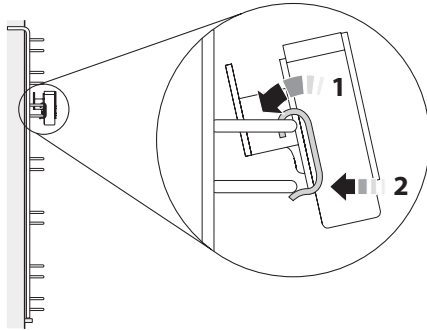

Fig. 2.25

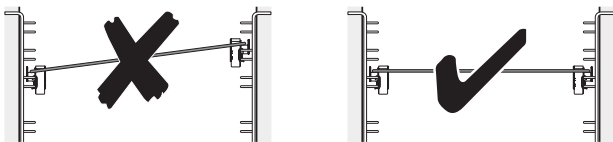
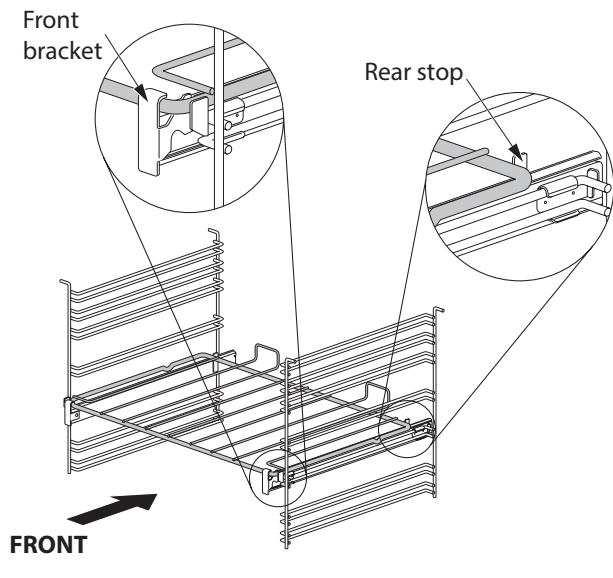
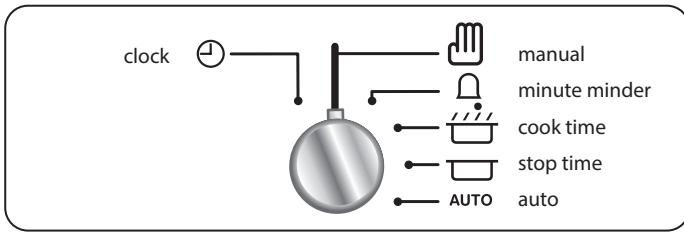

Fig. 2.26



3. Rotary clock

Symbol key



Setting the time

The clock must be set to the time of day before the oven will work

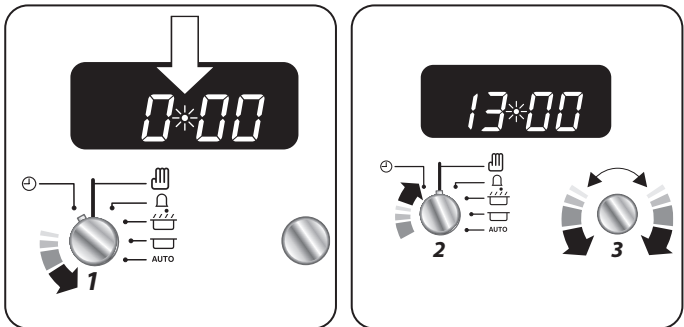

Setting the minute minder

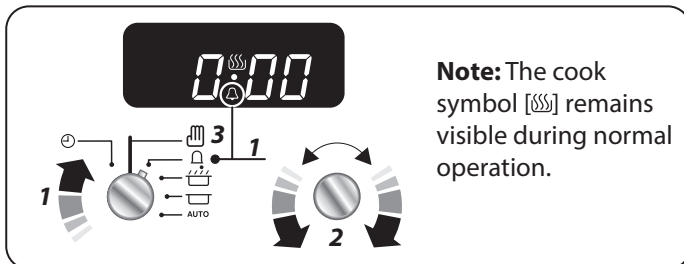

Cancel the timer alarm

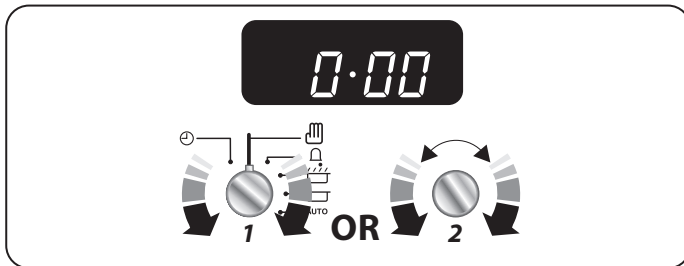

NOTE

When the Minute Minder is active the clock will not dim between the hours of 10 pm and 6 am

Beeper tone adjustment

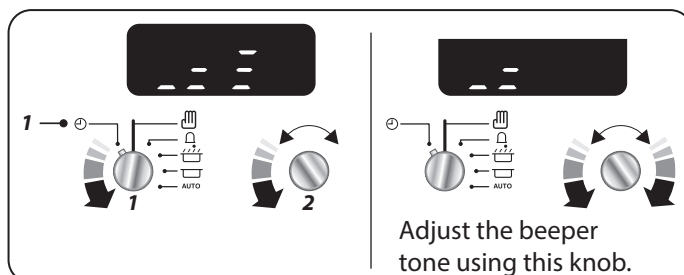

To stop the oven at a specific time of day (main oven only)

You have set the required temperature and function mode and you would like the oven to automatically stop.

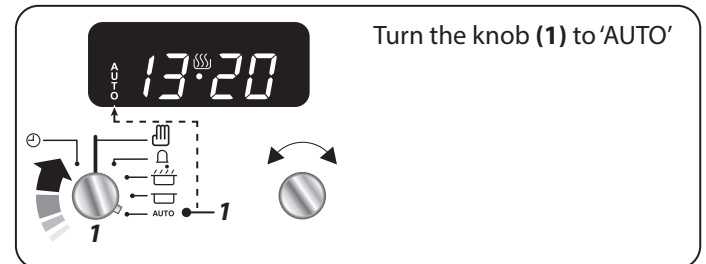
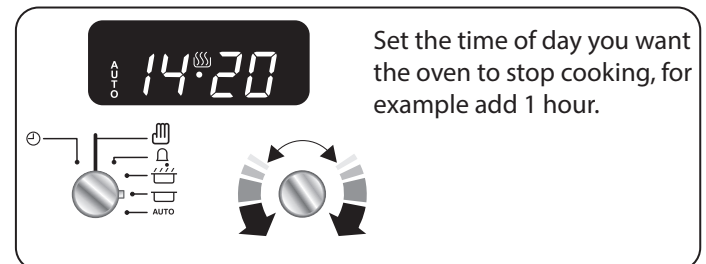
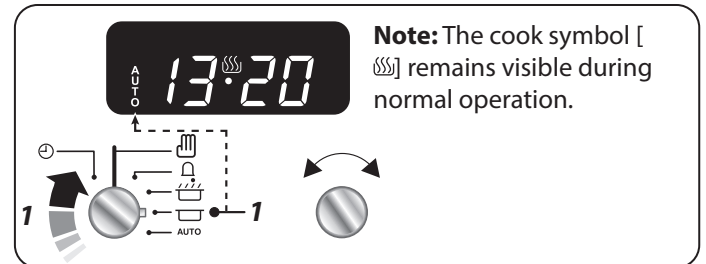

Check how much time you have left

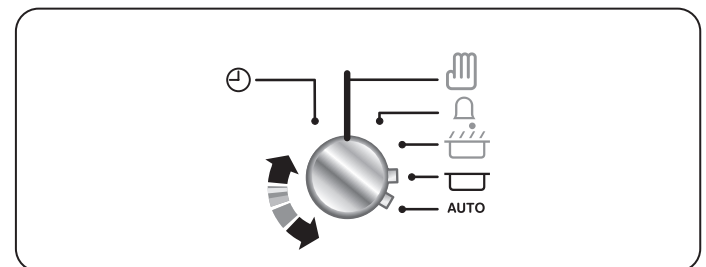

Alarm will sound when cooking has finished, to cancel follow this step.

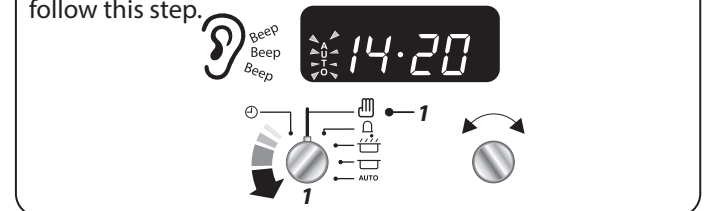

REMEMBER Turn the oven control knob (s) to 0.

NOTE

If the alarm is not manually switched off it will stop after approximately 2 minutes.

4. 3 button clock

Setting the time

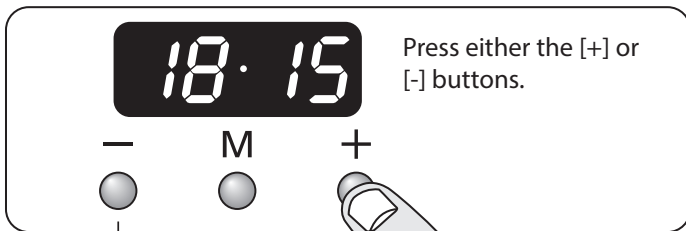
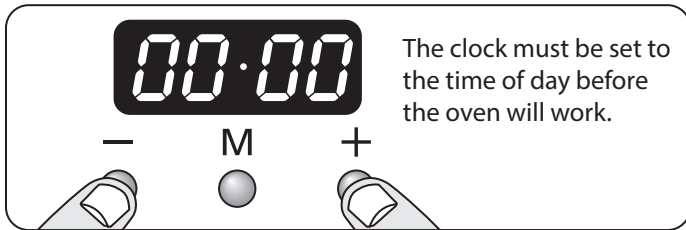

Minute Minder

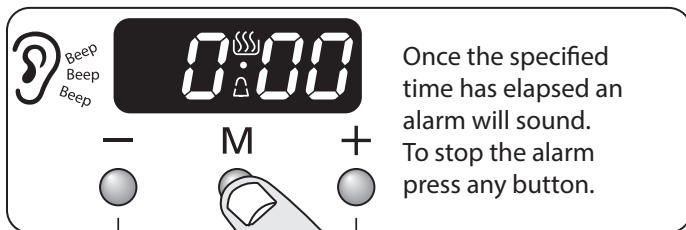
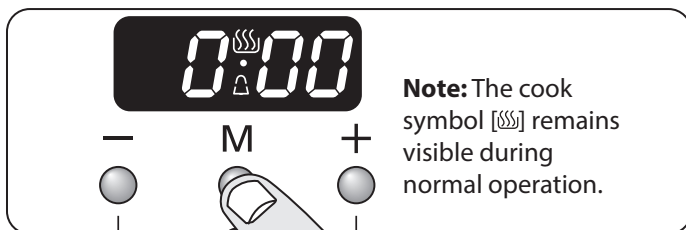

Reset the minute minder

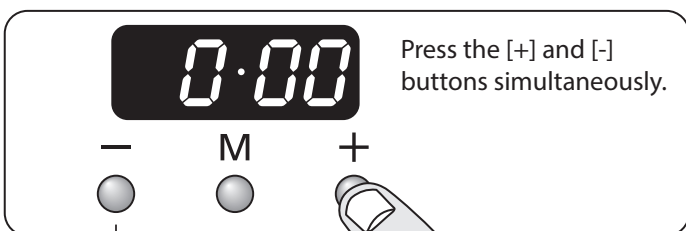
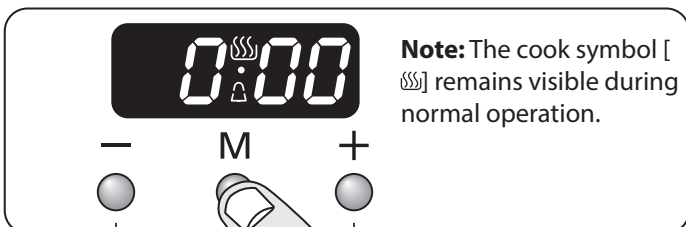

To stop the oven at a specific time of day

(*main oven only*) You have set the required temperature and function mode and you would like the oven to automatically stop.

Note: The cook symbol [flames] remains visible during normal operation.

Set the time of day you want the oven to stop cooking, for example add 1 hour.

Alarm will sound when cooking has finished, press any button to stop the alarm.

To start and stop the oven automatically

(main oven only)

Changing the frequency of the alarm

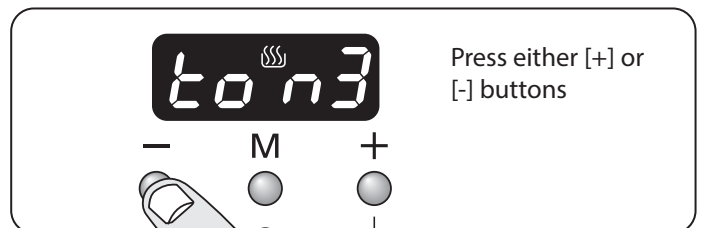
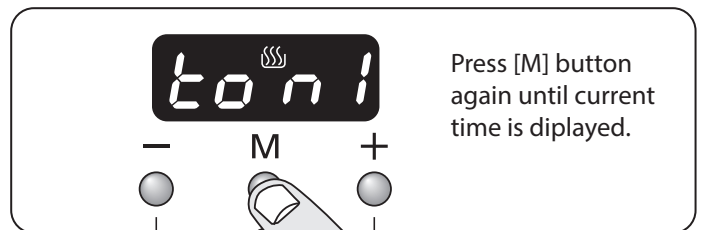

if the alarm is not stopped, it will stop automatically after 7 minutes.

5. Cooking tips

Cooking with a multifunction oven

Remember: not all modes are suitable for all food types. The oven cooking times given are intended for a guide only.

Tips on cooking with the timer

If you want to cook more than one dish, choose dishes that require approximately the same cooking time. However, dishes can be 'slowed down' slightly by using small containers and covering them with aluminium foil, or 'speeded up' slightly by cooking smaller quantities or placing them in larger containers.

Very perishable foods such as pork or fish should be avoided if a long delay period is planned, especially in hot weather.

⚠ DO NOT place warm food in the oven to be timed.

⚠ DO NOT use a timed oven that is already warm.

Whole poultry must be thoroughly defrosted before being placed in the oven. Check that meat and poultry are fully cooked before serving.

General oven tips

The wire shelves should always be pushed firmly to the back of the oven.

Baking trays with food cooking on them should be placed level with the front edge of the oven's wire shelves. Other containers should be placed centrally. Keep all trays and containers away from the back of the oven, as overbrowning of the food may occur.

When the oven is on, do not leave the door open for longer than necessary, otherwise the knobs may get very hot.

- Always leave a "finger's width" between dishes on the same shelf. This allows the heat to circulate freely around them.
- To reduce fat splashing when you add vegetables to hot fat around a roast, dry them thoroughly or brush lightly with cooking oil.
- Where dishes may boil and spill over during cooking, place them on a baking tray.
- Sufficient heat rises out of the right-hand oven while cooking to warm plates in the left-hand oven.
- If you want to brown the base of a pastry dish, preheat the baking tray for 15 minutes before placing the dish in the centre of the tray.

6. Cooking table

The oven control settings and cooking times given in the table below are intended to be used as **a guide only**. Individual tastes may require the temperature to be altered to provide a preferred result.

Food is cooked at lower temperature in a fan oven than in a conventional oven. When using recipes, reduce the fan oven temperature by 10°C and the cooking time by 5-10 minutes. The temperature in the fan oven does not vary with height in the oven so you can use any shelf.

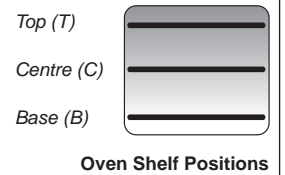

Food	Conventional Oven		Fan Oven	Approximate Cooking Time	
	Temperature °C & (Shelf Position)	Temperature °C	Temperature °C		
Meat					
Beef (no bone)	160 (C)	150	30-35 minutes per 500g +30-35 minutes.	<i>Thoroughly thaw frozen joints before cooking. Meat may be roasted at 220°C (210°C for fan oven) and the cooking time adjusted accordingly. For stuffed and rolled meats, add approximately 10 minutes per 500g, or cook at 200°C (190°C) for 20 minutes then 160°C (150°C) for the remainder.</i>	
	200 (C)	190	20-25 minutes per 500g +20-25 minutes.		
Lamb	160 (C)	150	30-35 minutes per 500g +30-35 minutes.		
	200 (C)	190	25-30 minutes per 500g +25-30 minutes.		
Pork	160 (C)	150	35-40 minutes per 500g +35-40 minutes.		
	200 (C)	190	25-30 minutes per 500g +25-30 minutes.		
Poultry					
Chicken	160 (C)	150	20-25 minutes per 500g +20-25 minutes.	<i>For stuffed poultry, you could cook at 200°C (190°C) for 20 minutes then 160°C (150°C) for remainder. Do not forget to include the weight of the stuffing. For fresh or frozen prepacked poultry, follow instructions on the pack. Thoroughly thaw frozen poultry before cooking.</i>	
	200 (C)	190	15-20 minutes per 500g +15-20 minutes.		
Turkey	160 (C)	150	20 minutes per 500g +20 minutes.		
	200 (C)	190	15 minutes per 500g +15 minutes.		
Duck	160 (C)	150	25-30 minutes per 500g.		
	200 (C)	190	20 minutes per 500g.		
Casserole	140-150 (C)	130-140	2-4 hours according to recipe.		
Yorkshire pudding	220 (C)	210	Large tins 30-35 minutes; individual 10-20 minutes.		
Fish					
Fillet	190 (C/B)	180	15-20 minutes.		
Whole	190 (C/B)	180	15-20 minutes per 500g.		
Steak	190 (C/B)	180	Steaks according to thickness.		
Cake					
Very rich fruit - Christmas, wedding, etc.	140 (C/B)	130	45-50 minutes per 500g of mixture.	<i>Using the conventional oven: when two tier cooking leave at least one runner space between shelves. Position the baking tray with the front edge along the front of the oven shelf.</i>	
Fruit 180 mm tin	150 (C/B)	140	2-2½ hours.		
Fruit 230 mm tin	150 (C/B)	140	Up to 3½ hours.		
Madeira 180 mm	160 (C/B)	150	80-90 minutes.	<i>If cooking a two tier load, the trays should be interchanged approximately halfway through the cooking time.</i>	
Queen cakes	190 (C/B)	180	15-25 minutes.		
Scones	220 (C/B)	210	10-15 minutes.		
Victoria sandwich				<i>Up to three tiers can be cooked in a fan oven at the same time but make sure to leave at least one runner space between each shelf being cooked on.</i>	
180 mm tin	180 (C/B)	170	20-30 minutes.		
210 mm tin	180 (C/B)	170	30-40 minutes.		
Desserts					
Shortcrust tarts	200 (C/B)	190	20-30 minutes on a preheated tray.		
Fruit pies	200 (C/B)	190	35-45 minutes.		
Tartlets	200 (C/B)	190	10-20 minutes according to size.		
Puff pastry	230 (C/B)	220	20-40 minutes according to size.		
Meringues	100 (C/B)	90	2-3 hours.		
Baked egg custard	160 (C/B)	150	45-60 minutes.		
Baked sponge pudding	190 (C/B)	180	40-45 minutes.		
Milk pudding	140-150 (C/B)	130-140	2 to 3 hours.		
Bread	220 (C)	210	20-30 minutes.		

7. Cleaning your cooker

Fig. 7.1

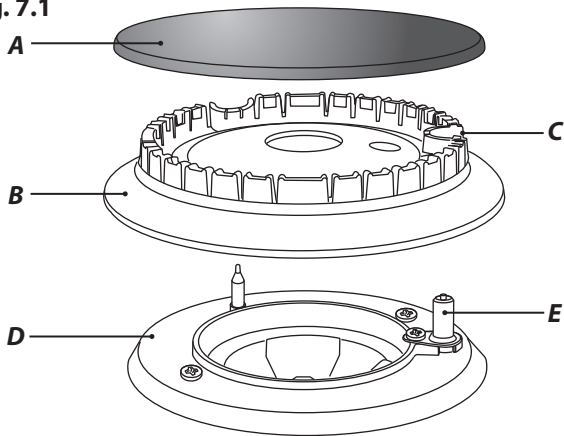

A – Cap, B – Head, C – Notch, D – Base, E – Electrode

Fig. 7.2

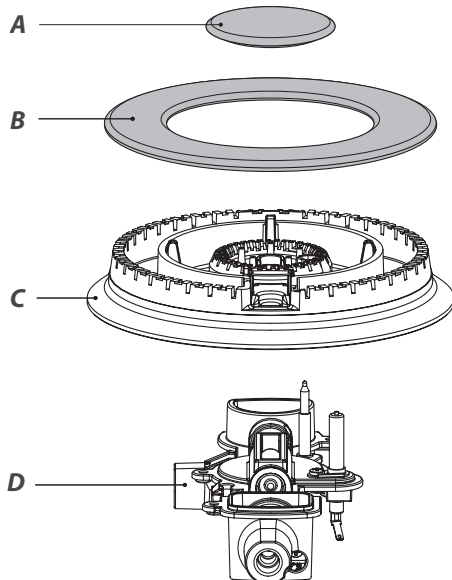

A – inner burner cap, B – outer burner cap,
C – burner head, D – wok burner base

Fig. 7.3

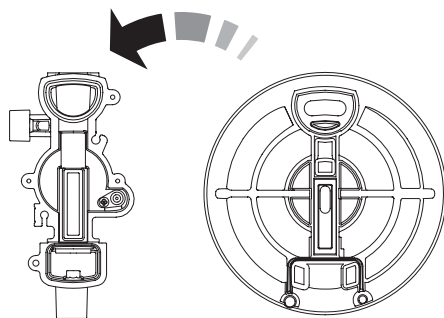

Isolate the electricity supply before carrying out any major cleaning. Allow the cooker to cool.

⚠ NEVER use paint solvents, washing soda, caustic cleaners, biological powders, bleach, chlorine based bleach cleaners, coarse abrasives or salt.

⚠ DO NOT mix different cleaning products – they may react together with hazardous results.

All parts of the cooker can be cleaned with hot soapy water – **but take care that no surplus water seeps into the appliance.**

Remember to switch the electricity supply back on and reset the clock before reusing the cooker.

Daily care

Cleaning the cooker is not a welcomed chore, but it has to be done to maintain efficiency and appearance. Remember it is better to wipe up any spills as they occur, this will prevent them burning on and becoming more difficult to remove later.

⚠ Make sure the flow of combustion and ventilation air to the cooker is unobstructed – for example by build-up of fats or grease.

On Natural gas the burners flames should be a bluish colour with, at most, a slight yellowish fringe.

On LP gas the flames may be “softer”. The cooktop burner flames may have a slight yellowish tip.

If the flame burns with a long white tip you should call for service.

Cleaning for spills

For spills and boil-overs that occur while cooking, turn off the burner as soon as possible and allow it to cool. Do not clean until the area is completely cooled down. Wipe up spills as soon as possible.

DO NOT allow surplus water to seep into the cooker.

Hotplate burners

The burner heads and caps can be removed for cleaning.

⚠ DO NOT put the burner heads in a dishwasher.

Make sure they are absolutely dry before replacing.

The single ring burners

When refitting the burner head, make sure that the notch lines up with the electrode or hole in the base. Check that the burner head is level and that the cap is fitted centrally on the burner head (Fig. 7.1).

The wok burner

When reassembling the wok burner (Fig. 7.2) turn over the large base ring and find the ‘D’ shaped area (Fig. 7.3). Turn the head until the ‘D’ matches the one on the burner base. Flip the burner over once again and place it on the burner base.

Check the burner slots are not blocked. If a blockage occurs, remove stubborn particles using a toothbrush (**Fig. 7.4**).

Now fit the two burner caps, making sure that they are seated properly.

Check the burner ports are not blocked. If a blockage occurs, remove stubborn particles using a piece of fuse wire.

Griddle

Always clean the griddle after use. Allow it to cool completely before removing. Immerse the griddle plate in hot soapy water. Use a soft cloth or, for stubborn stains, a nylon washing up brush.

If the griddle is washed in a dishwasher then some dishwasher residue may appear on the back. This is normal and will not affect the performance of your griddle.

The wok cradle

Recommended cleaning materials are hot soapy water, a moistened soap pad, cream cleaner or nylon scourer.

Oven and divider

Clean the oven and divider with a proprietary oven cleaner, suitable for enamel.

! **IMPORTANT: Before cleaning the divider make sure to remove the silicon sealing strip from the front edge – some oven cleaners can damage the seal. Remove the strip by gently pulling both ends to release the hooks holding it in place.**

Control panel and oven doors

Avoid using any abrasive cleaners including cream cleaners. For best results use liquid detergents.

The control panel and control knobs should only be cleaned with a soft cloth wrung out in clean hot soapy water – but take care that no surplus water seeps into the appliance.

Wipe with a clean dampened cloth then polish with a dry cloth. The oven doors should only be cleaned with a soft cloth wrung out in clean hot soapy water.

Removing the oven door outer panel

The outer door panel can be removed so that the inside of the glass can be cleaned. Open the door and remove the 2 screws in the inside face (**Fig. 7.5**). With the door closed, remove the 3 screws in the underside of the door.

Using the handle, carefully lift the door away.

Refit in reverse.

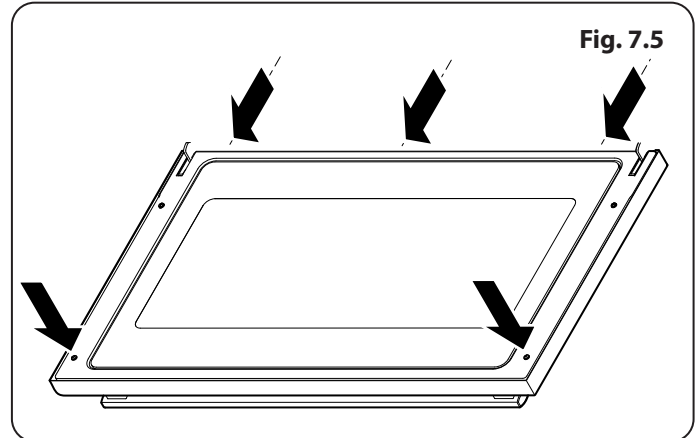
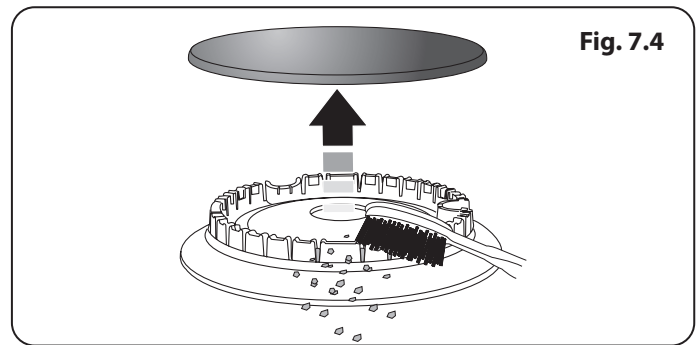

Cleaning table

Cleaners listed (**Table 7.1**) are available from supermarkets or electrical retailers as stated.

For enamelled surfaces use a cleaner that is approved for use on vitreous enamel.

Regular cleaning is recommended. For easier cleaning, wipe up any spillages immediately.

Hotplate		
Part	Finish	Recommended Cleaning Method
Hob top (including burner heads and caps)	Enamel, stainless steel, aluminium	Hot soapy water, soft cloth. Any stubborn stains remove gently with a nylon scourer.
Ceramic/induction hob	Toughened glass	Hot soapy water; cream cleaner/scourer if necessary.
Griddle plate (some models only)	Non-stick surface	Allow to cool. Wash in hot soapy water. Do not use abrasive cleaners/scourers. Dishwasher.
Warming zone (some models only)	Toughened glass	Hot soapy water, cream cleaner/scourer if necessary.
Outside of Cooker		
Part	Finish	Recommended Cleaning Method
Door, door surround and Storage drawer exterior	Enamel or paint	Hot soapy water, soft cloth. Any stubborn stains, remove gently with a liquid detergent.
	Stainless steel	E-cloth (electrical retailers) or microfibre all-purpose cloth (supermarket).
Sides and plinth	Painted surface	Hot soapy water, soft cloth.
Splashback/rear grille	Enamel or stainless steel	Hot soapy water, soft cloth. Cream cleaner, with care, if necessary.
Control panel	Paint, enamel or stainless steel	Warm soapy water. Do not use abrasive cleaners on lettering.
Control knobs/handles & trims	Plastic/chrome, copper or lacquered brass	Warm soapy water, soft cloth.
	Brass	Brass polish.
Oven door glass/glass lid	Toughened glass	Hot soapy water, cream cleaner/scourer if necessary.
Oven and Grill		
Part	Finish	Recommended Cleaning Method
Sides, floor & roof of oven NOT 'COOK & CLEAN' OVEN PANELS (see below)	Enamel	Any proprietary oven cleaner that is suitable for enamel. CAUTION: CORROSIVE/CAUSTIC OVEN CLEANERS: FOLLOW MANUFACTURER'S INSTRUCTIONS. Do not allow contact with the oven elements.
'Cook & Clean' oven panels (some models only)	Special enamel that partly cleans itself	This surface cleans itself at 200°C and above, or the panels can be removed and washed with hot soapy water and a nylon brush.
Oven shelves, Handyrack, grill trivet, Handygrill rack (some models only)	Chrome	An oven interior cleaner that is suitable for chrome. Soap filled pad. Dishwasher.
Grill pan/meat tin (some models only)	Enamel	Hot soapy water. Soap filled pad. Dishwasher.

Table 7.1

8. Troubleshooting

Hotplate/Cooktop ignition or hotplate burners faulty

Is the power on? Is the clock illuminated?

If not, there maybe something wrong with the power supply.

Are the sparker (ignition electrode) or burner slots blocked by debris? See (Fig. 8.1 and Fig. 8.2).

Are the burner trim and caps correctly located? See the section on 'Cleaning'.

Hotplate/Cooktop burners will not light

Make sure that the burner parts have been replaced correctly after wiping or removing for cleaning.

Check that there is not a problem with your gas supply. You can do this by making sure that other gas appliances you may have are working.

Do the burners spark when you push the button?

If not, verify that the power is on by checking that the clock is illuminated.

Steam is coming from the oven

When cooking foods with high water content (e.g. oven fries) there may be some steam visible at the rear grille.

Take care when opening the oven door, as there may be a momentary puff of steam when the oven door is opened. Stand well back and allow any steam to disperse.

What cleaning materials are recommended for the cooker?

See the 'Cleaning' section for recommended cleaning materials.

 **Never use caustic or abrasive cleaners as these will damage the surface.**

An oven fan is noisy

The note of the oven fan may change as the oven heats up – this is perfectly normal.

If there is an installation problem and I don't get my original installer to come back to fix it who pays?

You do. Service organizations will charge for their call outs if they are correcting work carried out by your original installer. It is in your interest to track down your original installer.

Power failure

In the event of a failure in the electrical supply, remember to reset the clock to make sure that the timed oven continues to operate.

Food is cooking too slowly, too quickly, or burning

Cooking times may differ from your previous oven.

Check that you are using the recommended temperatures and shelf positions – see the oven cooking guide. The oven control settings and cooking times are intended to be used **only** as a guide.

Individual tastes may require the temperature to be altered either way, to get the results you want.

The oven is not cooking evenly

Do not use a baking tray with dimensions larger than those specified in the section on 'General Oven Tips'.

If you are cooking a large item, be prepared to turn it round during cooking.

If two shelves are used, check that space has been left for the heat to circulate. When a baking tray is put into the oven, make sure that it is placed centrally on the shelf.

Check that the door seal is not damaged and that the door catch is adjusted so that the door is held firmly against the seal.

A dish of water when placed on the shelf should be the same depth all over. (For example, if it is deeper at the back, then the back of the cooker should be raised up or the front lowered.) If the cooker is not level, arrange for your supplier to level it for you.

Oven not coming on

Is the power on? Is the clock illuminated? If not, there may be something wrong with the power supply.

Is the cooker supply on at the isolator switch? Has the time of day been set?

The timed oven is not coming on when automatic cooking

Has the oven knob been left in the OFF position by mistake?

Oven temperature getting hotter as the cooker gets older

If turning the temperature down using the oven control knob has not worked, or has only worked for a short time, then you may need a new thermostat. This should be fitted by a qualified service person.

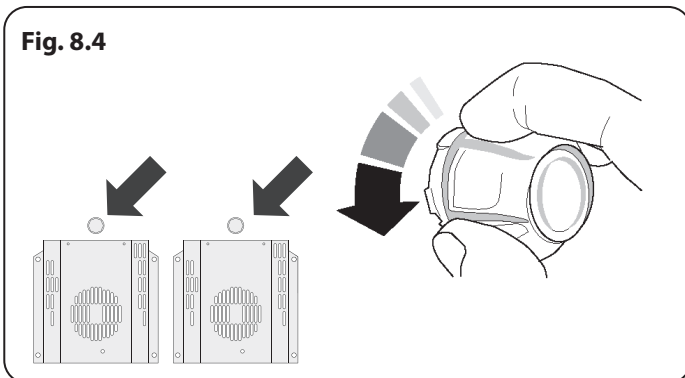
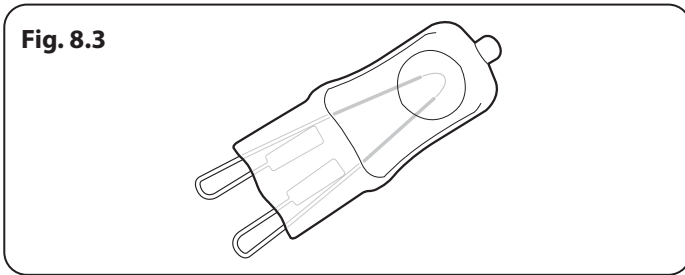
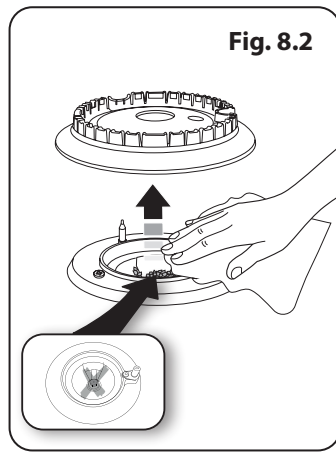
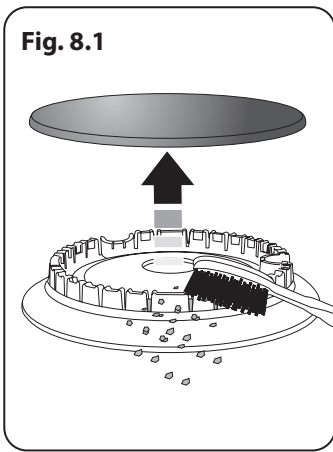

Oven light is not working

The bulb has probably burnt out. You can buy a replacement bulb (which is not covered under the warranty) from a good electrical shop. Ask for a 40 W – 230 V halogen lamp (G9) (**Fig. 8.3**).

Turn off the power at the circuit breaker.

Before removing the existing bulb, turn off the power supply and make sure that the oven is cool. Open the oven door and remove the oven shelves.

Unscrew the bulb cover by turning counter-clockwise. It may be very stiff (**Fig. 8.4**).

Pull the existing bulb to remove it. When handling the replacement bulb, avoid touching the glass with your fingers, as oils from your hands can cause premature failure. Push, click in the replacement bulb.

Replace the bulb cover by turning it a quarter turn, clockwise.

The fascia gets hot when I use the oven

The cooker is cooled by a fan. If the fascia becomes excessively hot when the cooker is in use then the cooling fan may have failed. Should this occur please contact your installer, a qualified repair engineer or Customer Service to arrange for its repair.

INSTALLATION

Check the appliance is electrically safe and gas sound when you have finished.







9. Installation

Dear Installer

Before you start your installation, please complete the details below, so that, if your customer has a problem relating to your installation, they will be able to contact you easily.

Installer's Name
Installer's Company
Installer's Telephone Number
Appliance Serial Number

Safety requirements and regulations

-  This cooker must be installed in accordance with the relevant instructions in this booklet, with the relevant national and local regulations, and with the local gas and electricity supply companies' requirements.
-  This cooker is a Class 2 Subclass 1 appliance.
-  Before installation, make sure that the cooker is suitable for your gas type and supply voltage. See the data badge.
-  The appliance must be installed in accordance with the regulations in force and only in a well ventilated space.
-  Read the instructions before installing or using this appliance.
-  In your own interest and that of safety, it is law that all gas appliances be installed by competent persons. Failure to install the appliance correctly could invalidate any warranty or liability claims and lead to prosecution.
-  This appliance can be converted for use on another gas.

Provision of ventilation

This appliance is not connected to a combustion products evacuation device. Particular attention shall be given to the relevant requirements regarding ventilation.

All rooms require a window that can be opened, or equivalent, while some rooms require a permanent vent in addition to the window.

Location of cooker

The cooker may be installed in a kitchen/kitchen diner but **NOT** in a room containing a bath or shower.

This appliance is designed for domestic cooking only. Use for any other purpose could invalidate any warranty or liability claim.

NOTE: An appliance for use on LPG must not be installed in a room or internal space below ground level, e.g. in a basement.

Conversion

A conversion kit for another gas is available for the cooker.

If the appliance is to be converted to another gas we recommend that this is carried out before installation.

-  **We recommend an overpressure shut-off device or pressure relief valve be used in any LPG installation to prevent exposure of downstream fittings / appliances to excessive pressure (over 75mbar) in event of regulator failure.**

After converting the appliance, please attach the Gas Conversion sticker over the appropriate area of the data badge – this will identify the gas type for which the appliance is now set.

INSTALLATION

Check the appliance is electrically safe and gas sound when you have finished.

You will need the following equipment to complete the cooker installation satisfactorily:

- Stability bracket: If the cooker is to be supplied with gas through a flexible hose, a stability bracket or chain **MUST** be fitted. **These are not supplied with the cooker** but are available at most builders' merchants.
- Gas pressure tester/manometer.
- Flexible gas hose: Must be in accordance with the relevant standards.
- Multimeter: For electrical checks.

You will also need the following tools:

1. Electric drill
2. Masonry drill bit (only required if fitting the cooker on a stone or concrete floor)
3. Wall plugs (only required if fitting the cooker on a stone or concrete floor)
4. Steel tape measure
5. Cross head screwdriver
6. Flat head screwdriver
7. 4 mm & 3 mm Allen keys
8. Spirit level
9. Pencil
10. Adjustable spanner
11. Screws for fitting stability bracket
12. 13 mm spanner or socket wrench

INSTALLATION

Check the appliance is electrically safe and gas sound when you have finished.

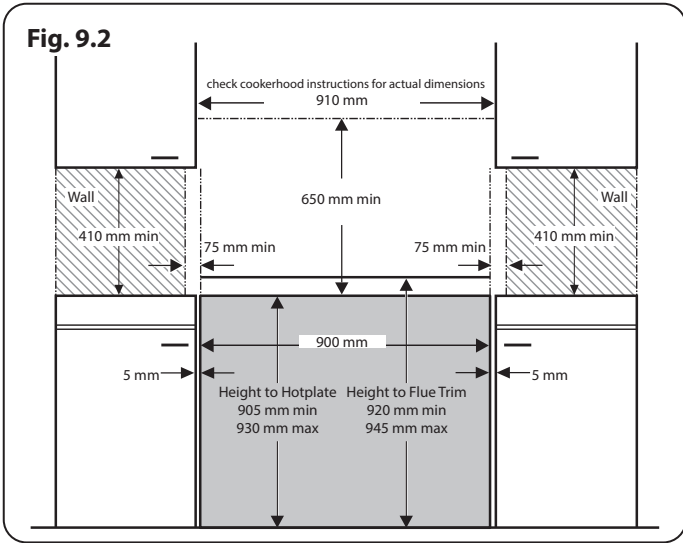
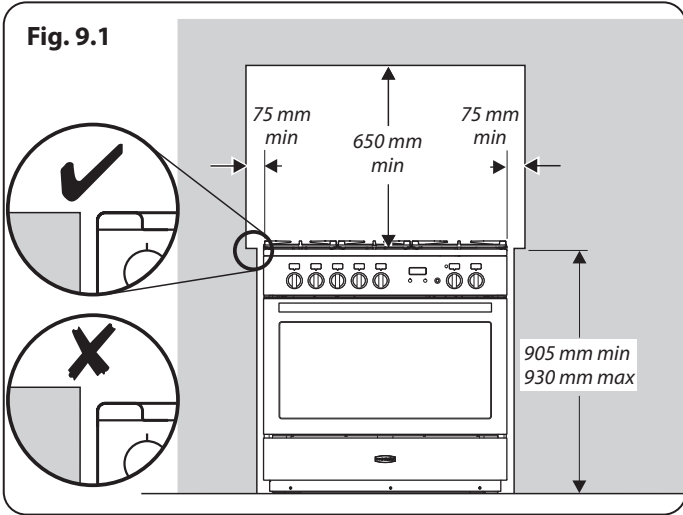

Checking the parts:

Pan supports	Teppanyaki (supplied)
Griddle (optional)	Wok cradle
Full capacity shelf	Grill pan tray support
2 grill pans & trivets	Divider
4 ladder side supports	3 energy saving shelves
Plinth	Splashback (Classic only)
Towel rail & handle (Classic only)	

INSTALLATION

Check the appliance is electrically safe and gas sound when you have finished.

Positioning the cooker

Fig. 9.1 and **Fig. 9.2** show the minimum recommended distance from the cooker to nearby surfaces.

The cooker should not be placed on a base.

Fig. 9.1 and **Fig. 9.2** Cookers installed into recess: The cooker must have side clearance **ABOVE** hob level of 75mm up to a height of 410mm. This can be reduced to 25mm if the surface of the side wall is non-combustible.

A minimum space of 650 mm is required between the top of the hob and a horizontal combustible surface.

*Any cookerhood should be installed in accordance with the hood manufacturer's instructions.

**Any splashback must be fitted in accordance with the manufacturers instructions. Allowance should be made for the additional height of the flue trim, which is fitted to the cooker hob.

Surfaces of furniture and walls at the sides and rear of the appliance should be heat, splash and steam resistant. Certain types of vinyl or laminate kitchen furniture are particularly prone to heat damage and discolouration. We cannot accept responsibility for damage caused by normal use of the cooker to any material that de-laminates or discolours at temperatures less than 65°C above room temperature.

DO NOT box the cooker in – it must be possible to move the cooker in and out for cleaning and servicing.

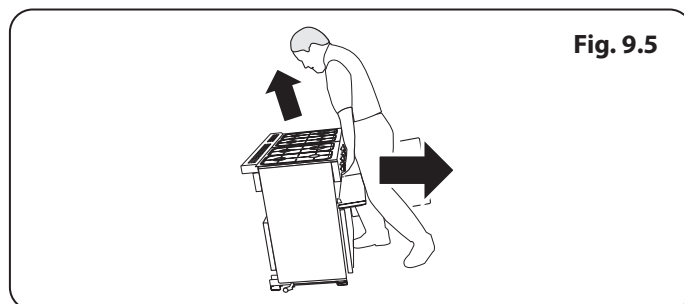
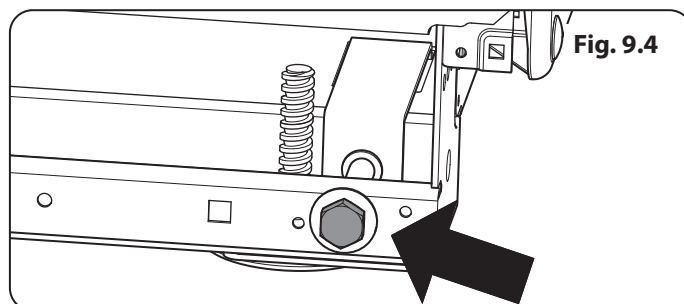
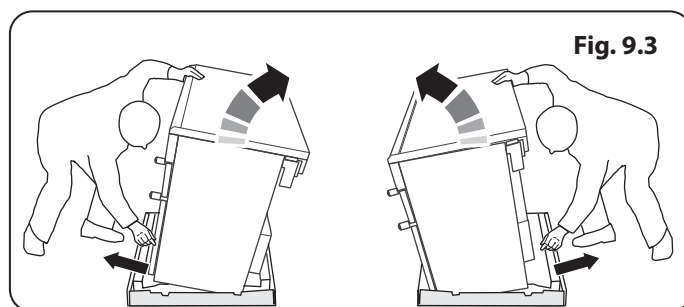

Moving the cooker

⚠ On no account try and move the cooker while it is plugged into the electricity supply.

⚠ The cooker is very heavy, so take extra care.

We recommend that two people manoeuvre the cooker. Make sure that the floor covering is firmly fixed, or removed, to prevent it being disturbed when moving the cooker around.

To help you, there are two levelling rollers at the back, and two screw-down levelling feet at the front.

Remove the polystyrene base pack. From the front, tilt the cooker backwards and remove the front half of the polystyrene base (**Fig. 9.3**).

Repeat from the back and remove the rear half of the polystyrene base.

Lowering the two rear rollers

To adjust the height of the rear of the cooker, first fit a 13 mm spanner or socket wrench onto the hexagonal adjusting nut (**Fig. 9.4**). Rotate the nut – clockwise to raise – counter-clockwise to lower.

Make 10 complete (360°) turns clockwise.

Make sure you lower **BOTH REAR ROLLERS**.

INSTALLATION

Check the appliance is electrically safe and gas sound when you have finished.

Fig. 9.6

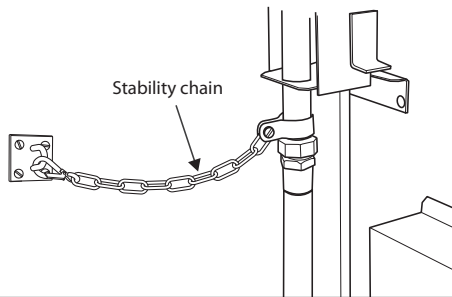

Completing the move

Unfold the rear edge of the cardboard base tray. Open the oven door(s) so that you can get a good grip on the bottom of the fascia panel as you move the oven (Fig. 9.5).

Carefully push the cooker backwards off the base tray. Remove the base tray.

Position the cooker close to its final position, leaving just enough space to get behind it.

⚠ DO NOT use the door handles or control knobs to manoeuvre the cooker.

Fig. 9.7

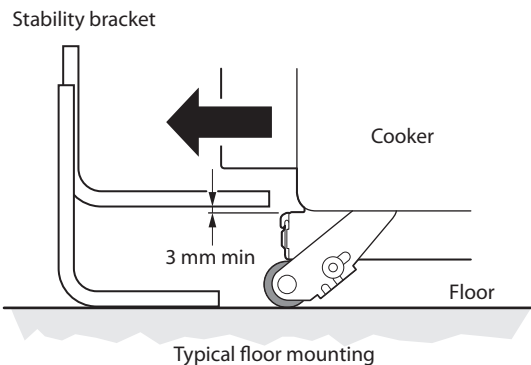

Levelling

You are recommended to use a spirit level on a shelf in one of the ovens to check for level.

Place the cooker in its intended position, taking care not to twist it within the gap between the kitchen units as damage may occur to the cooker or the units.

The front feet and rear rollers can be adjusted to level the cooker. To adjust the height of the rear of the cooker turn the adjusting nuts at the front bottom corners of the cooker. To set the front feet turn the bases to raise or lower.

Fig. 9.8

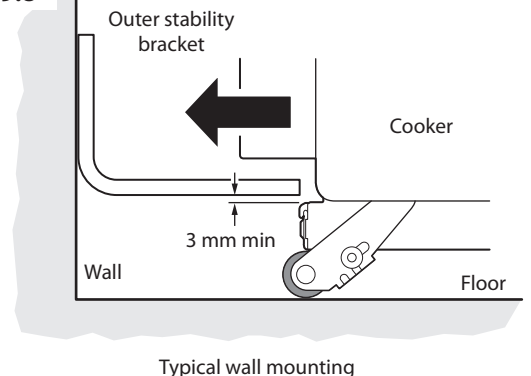

Fitting the stability bracket or chain

Unless otherwise stated, a cooker using a flexible gas connector must be secured with a suitable stability device.

Suitable stability devices are shown in Fig. 9.6, Fig. 9.7 and Fig. 9.8.

If you are using a stability chain (Fig. 9.6) then the chain should be kept as short as is practicable and fixed firmly to the rear of the cooker.

If you are using a stability bracket (Fig. 9.7 and Fig. 9.8), then adjust the bracket to give the smallest practicable clearance between the bracket and the engagement slot in the rear of the cooker.

Fit the bracket so that it engages as far as possible over the chassis of the cooker.

Repositioning the cooker following connection

If you need to move the cooker once it has been connected then you need to unplug it and, having gripped under the fascia panel and lifted the front of the cooker slightly (Fig. 9.5), you need to check behind the cooker to make sure that the gas hose is not caught.

As you progress, make sure that both the electricity cable and gas hose always have sufficient slack to allow the cooker to move.

INSTALLATION

Check the appliance is electrically safe and gas sound when you have finished.

With a stability chain fitted, release it as you ease the cooker out. **DO NOT** forget to refit it when you replace the cooker.

When you replace the cooker, again check behind to make sure that the electricity cable and gas hose are not caught or trapped.

Gas connection

This must be in accordance with the relevant standards.

The flexible hose (not supplied with the cooker) must be in accordance with the relevant standards. Hoses may be purchased at most builders' merchants.

The connector is located just below the hotplate level at the rear of the cooker. If in doubt contact your supplier.

The rear cover boxes limit the position of the supply point.

Because the height of the cooker can be adjusted and each connection is different, it is difficult to give precise dimensions.

Although a 900 mm hose can be used, a 1250 mm hose will allow slightly more flexibility in the positioning of the bayonet and make moving the cooker easier.

The hose should be fitted so that both inlet and outlet connections are vertical so that the hose hangs downwards in a 'U' shape.

Ideally the hose supply connection should be within the shaded area 'A' (Fig. 9.9).

For Natural Gas, the flexible hose must be in accordance with local codes and regulations. For LP Gas, it should be capable of 50 mbar pressure, 70 °C temperature rise, and carry a red stripe, band or label. If in doubt contact your supplier.

Screw connect the threaded end of the hose into the gas inlet.

After completing the gas connection, make sure that the cooker is gas sound with a pressure test.

Pressure testing

The gas pressure can be measured at one of the hotplate burner injectors (not a wok burner).

Lift off a burner head. Fit the pressure gauge to the injector. Turn on and light one of the other hotplate burners.

Turn on the control knob for the burner with the pressure gauge fitted to let gas through.

See the data badge for test pressures.

Turn off the burners. Make sure that you reassemble the burner top in the correct way on the burner body.

Fig. 9.10

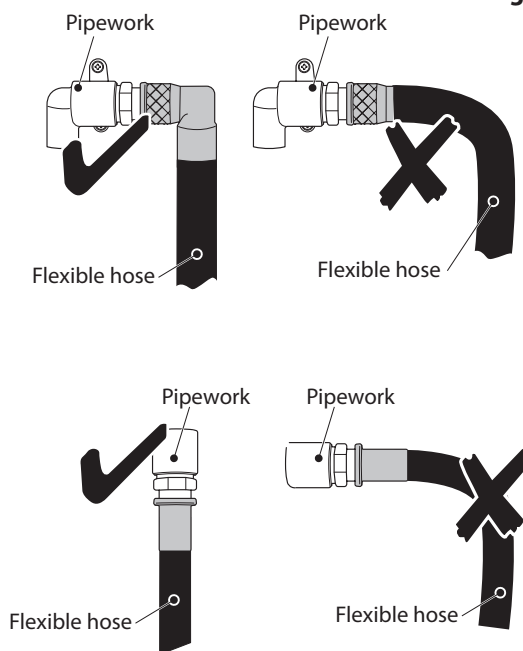
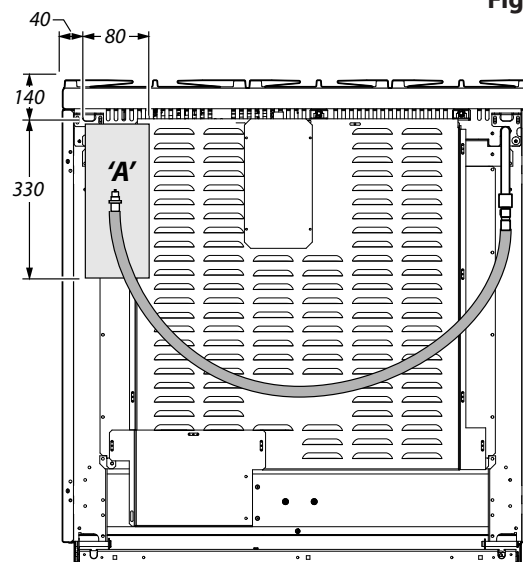

Fig. 9.9



All dimensions in millimetres

INSTALLATION

Check the appliance is electrically safe and gas sound when you have finished.

Current Operated Earth Leakage Breakers

The combined use of your cooker and other domestic appliances may cause nuisance tripping, so we recommend that the cooker is protected on an individual RCD (Residual Current Device) or RCBO (Residual Current Breaker with Overload).

IF IN DOUBT, PLEASE CONSULT A SUITABLY QUALIFIED ELECTRICIAN.

Fig. 9.11

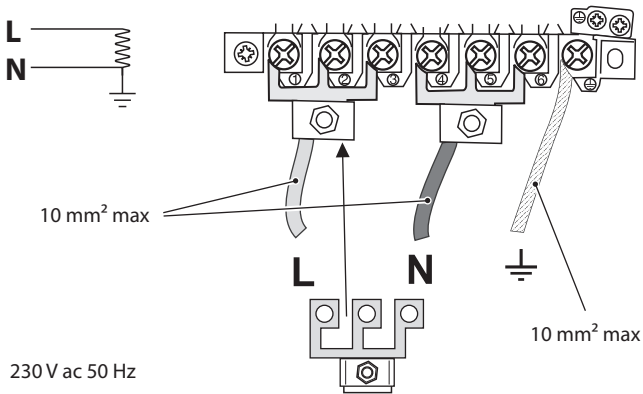
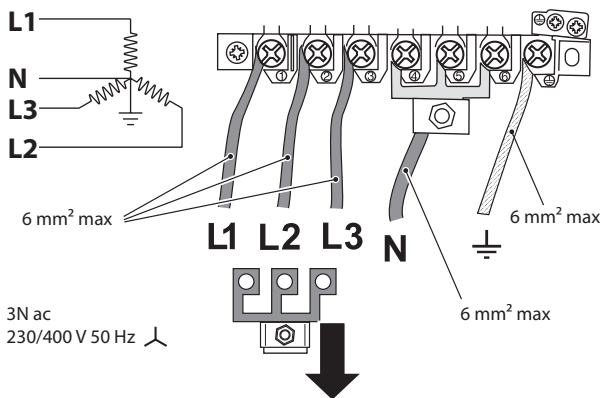

Fig. 9.12



Electrical connection

The cooker must be installed by a suitably qualified electrician to comply with the relevant electrical regulations, and also the local electricity supply company requirements.

⚠ WARNING: THE APPLIANCE MUST BE EARTHED.

Note: The cooker must be connected to the correct electrical supply as stated on the voltage label on the cooker, through a suitable cooker control unit incorporating a double-pole switch, having a contact separation of at least 3 mm in all poles.

⚠ The cooker MUST NOT be connected to an ordinary domestic power point.

Access to the mains terminal is gained by removing the electrical terminal cover box on the back panel. Connect the mains cable to the correct terminals for your electrical supply type (**Fig. 9.11** and **Fig. 9.12**). Check that the links are correctly fitted and that the terminal screws are tight.

Secure the mains cable using the cable clamp.

INSTALLATION

Check the appliance is electrically safe and gas sound when you have finished.

10. Final checks and fittings

Hotplate check

Check each burner in turn. There is a flame supervision device (FSD) that stops the flow of gas to the burner if the flame goes out.

To light a burner, push in and turn the associated control knob to the high position indicated by the large flame symbol (🔥).

The igniter should spark and light the gas. Keep holding the knob pressed in to let the gas through to the burner for a few seconds.

If, when you let go of the control knob, the burner goes out, then the FSD has not been bypassed. Turn the control knob to the Off position and wait for one minute before you try again, this time making sure to hold in the control knob for slightly longer.

Oven check

Turn on the oven and check that it starts to heat up. Check that the oven lights are working. Turn off the oven.

Note: The oven light bulb is not included in the guarantee.

Fitting

Fitting the Handle and Handrail (Classic FX)

Remove the 4 mm Allen screws from the doors (**Fig. 10.1**). Fit the door handle and secure using the 4 mm screws.

⚠ The handle should be above the fixings.

Remove the 4 mm Allen screws from the top corners of the fascia (**Fig. 10.2**). Fit the front handrail in position and secure using the 4 mm screws.

Fitting the Splashback (Classic FX)

Position the splashback on the rear of the hotplate and secure with the screws supplied.

Removing the oven door

To remove the oven door, open the door fully. Swivel the locking 'U' clips forward to the locking position (**Fig. 10.3**). Grip the sides of the door, lift upwards and then slide the door forwards (**Fig. 10.4**).

Refitting the oven door

To refit the door, slide the hinges back into their slots. Rotate the locking 'U' clips back to fit onto the hinges.

Fitting the plinth

Remove the 3 screws for the plinth mounts along the front bottom edge of the range (**Fig. 10.5**). Fasten the plinth using these screws.

Customer care

Installer: Please complete your details in this guide, inform the user how to operate the cooker and hand over the instructions.

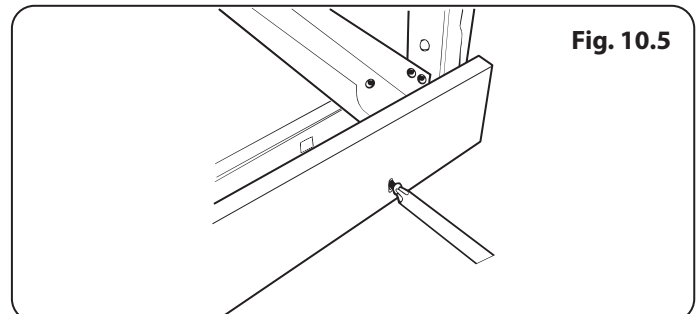
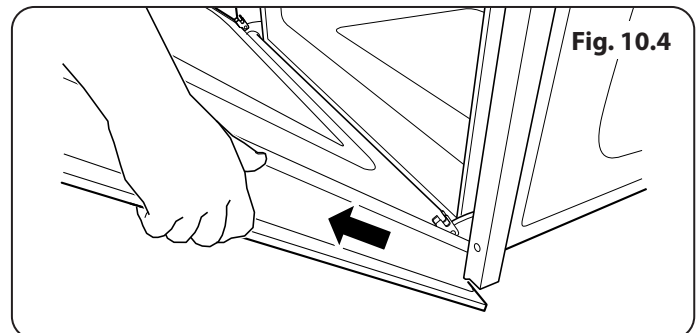
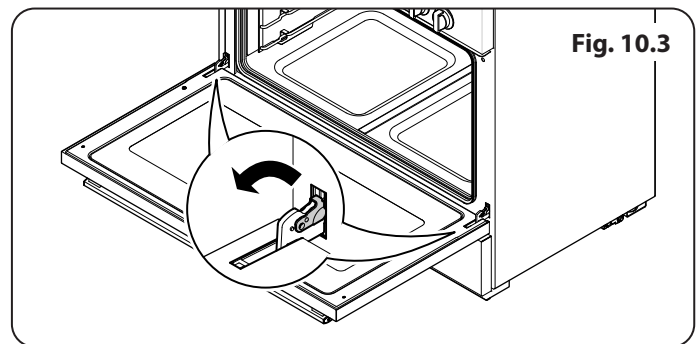
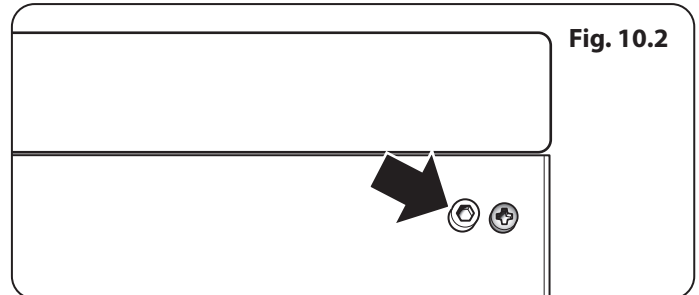
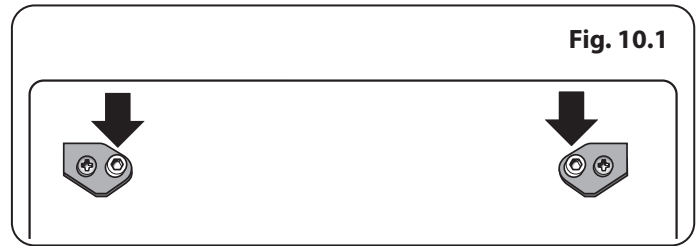

INSTALLATION

Check the appliance is electrically safe and gas sound when you have finished.

Fitting the drawer

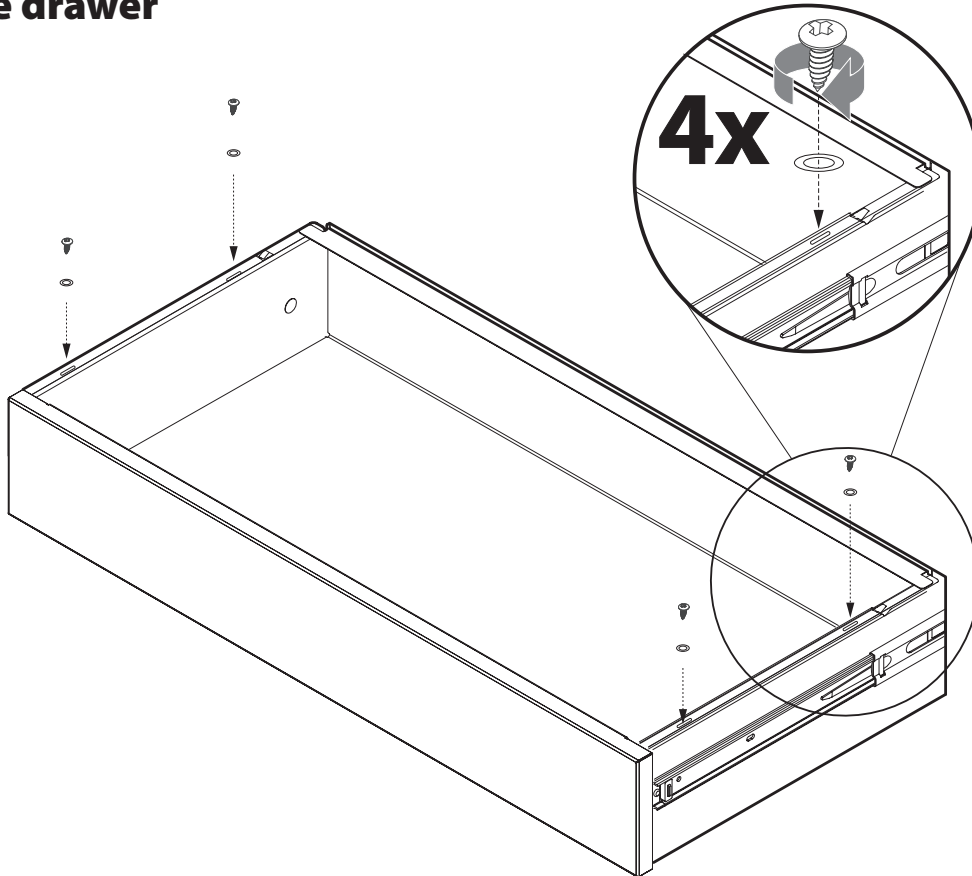

Removing the drawer

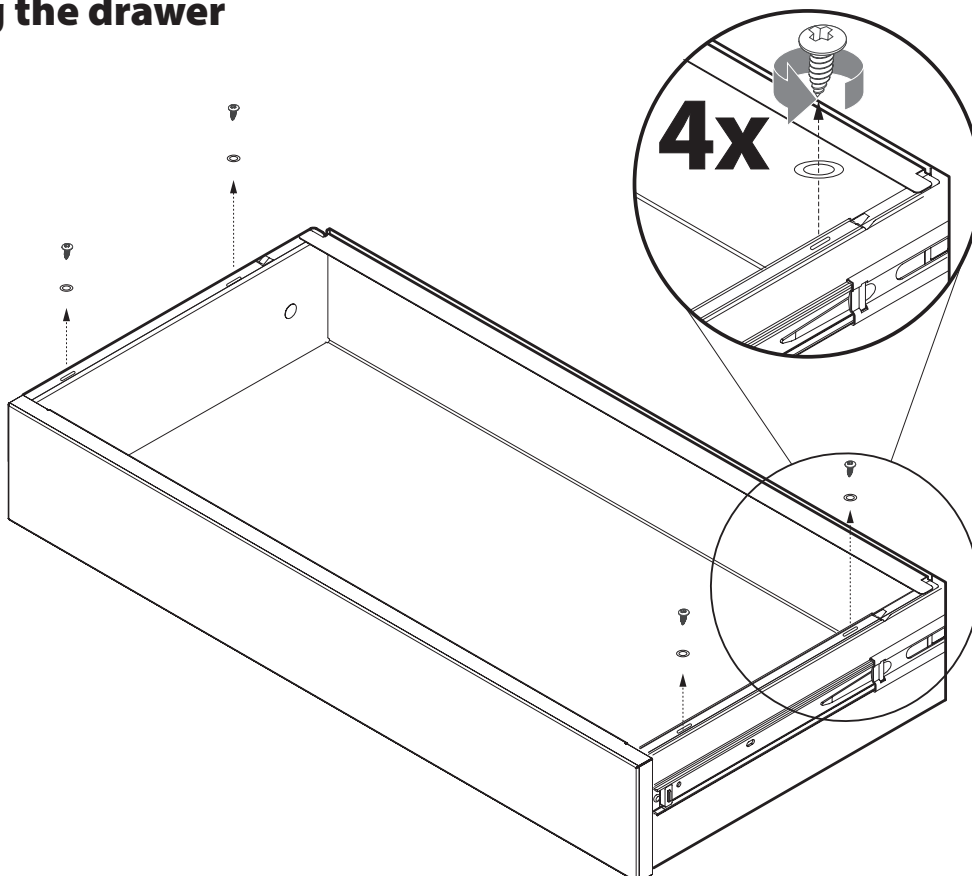

11. Circuit diagram

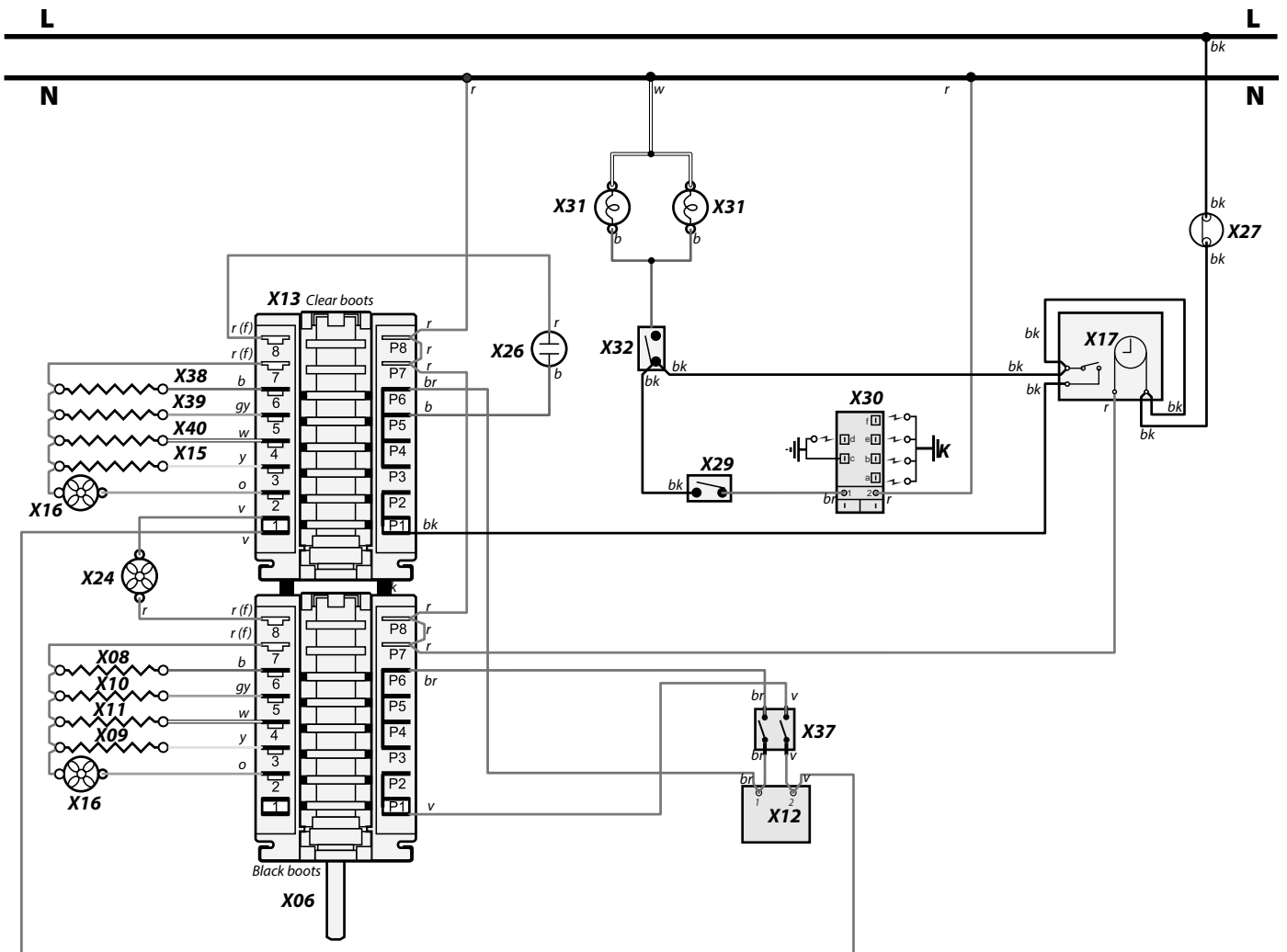

Key

The connections shown in the circuit diagram are for single-phase. The ratings are for 230V 50Hz.

Code	Description
X06	Left Hand Oven Multifunction Switch
X08	Left Hand Oven Base Element
X09	Left Hand Oven Fan Element
X10	Left Hand Oven Top Outer Element
X11	Left Hand Oven Top Inner Element
X12	Right Hand Oven Thermostat
X13	Right Hand Oven Multifunction Switch
X15	Right Hand Oven Fan Element
X16	Oven Fan
X17	Clock / Timer

Code	Description
X24	Cooling fan
X26	Neon
X27	Thermal cut out
X29	Ignition switch
X30	Spark generator
X31	Oven light
X32	Oven light switch
X37	Divider Switch
X38	Right-hand Oven Base Element
X39	Right-Hand Oven Top Outer Element
X40	Right-Hand Oven Top Inner Element

Code	Colour
b	Blue
br	Brown
bk	Black
or	Orange
r	Red
v	Violet
w	White
y	Yellow
g/y	Green/yellow
gr	Grey
r(f)	Red

12. Technical data

THE COOKER IS CATEGORY: Cat II_{2H3+}. It is supplied set for group H natural gas. A conversion kit from NG to LP is available for the cooker. **INSTALLER:** Please leave these instructions with the user. **DATA BADGE LOCATION:** Cooker back, serial number repeater badge below oven door opening. **COUNTRY OF DESTINATION:** GB, IE, FR, NL, DE, SE, IT, AT, CH, LU, BE.

Connections This appliance is supplied set for one of the gas categories listed in the table below, dependant on country of destination.

Category	Country	Natural Gas	L.P. Gas
Cat II _{2H3+}	GB, IE	G20 20mbar	G30 butane 29mbar G31 propane 37mbar
Cat II _{2E3B/P} Cat II _{2ELL3B/P}	DE	G20 20mbar G25 20mbar	G30 butane 29mbar G31 propane 29mbar G30 butane 50mbar G31 propane 50mbar
Cat II _{2E+3+}	FR, BE	G20 20/25mbar	G30 butane 29mbar G31 propane 37mbar
Cat II _{2H3B/P}	SE, CH	G20 20mbar	G30 butane 29mbar G31 propane 29mbar
Cat II _{2L3B/P}	NL	G25 25mbar	G30 butane 29mbar G31 propane 29mbar

Hotplate Ratings

See the data badge for information on the gas and pressure for which the appliance is set.

If a conversion is required follow the conversion instructions.

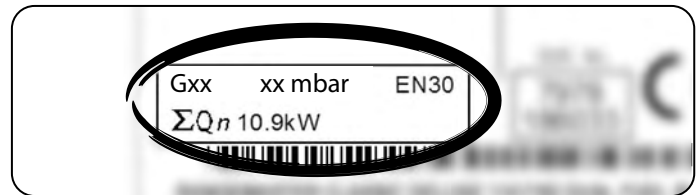

Hotplate ratings

Hotplate	Bypass Screw*	Natural Gas G20 20 mb		L.P. Gas 29/37 mb	
			Injector		Injector
Wok burner	62	4.0 kW	148	4.0 kW (291 g/h)	103
Rapide/ Large Burner	40	3 kW	134	3.0 kW (218 g/h)	87
Semi Rapide / Medium Burner	32	1.7 kW	109	1.7 kW (124 g/h)	68
Auxiliary / Small Burner	28	1 kW	75	1.0 kW (73 g/h)	51
Hotplate	Bypass Screw*	Natural Gas G25 25 mb		L.P. Gas 29 mb	
			Injector		Injector
Wok burner	62	4.0 kW	152	4.0 kW (291 g/h)	103
Rapide/ Large Burner	40	3 kW	135	3.0 kW (218 g/h)	87
Semi Rapide / Medium Burner	32	1.7 kW	105	1.7 kW (124 g/h)	68
Auxiliary / Small Burner	28	1 kW	76	1.0 kW (73 g/h)	51

Hotplate	Bypass Screw*	Natural Gas G25 20 mb		L.P. Gas 50 mb	
			Injector		Injector
Wok burner	62	4.0 kW	163	4.0 kW (291 g/h)	86
Rapide/ Large Burner	40	3 kW	141	3.0 kW (218 g/h)	81
Semi Rapide / Medium Burner	32	1.7 kW	113	1.7 kW (124 g/h)	60
Auxiliary / Small Burner	28	1 kW	85	1.0 kW (73 g/h)	46

* The valves in this cooker are fitted with adjustable bypass screws. The cooker is supplied with the bypass screws set for Natural Gas. For LPG conversion the bypass screws must be screwed all the way down.

Dimensions

Model	Professional+ FX 90 Dual Fuel	
Overall height	minimum 905 mm	maximum 930 mm
Overall width	900 mm	
Overall depth	608 mm excluding handles, 642 mm including handles	
Minimum height above the hotplate	650 mm	

Model	Classic FX 90 Dual Fuel	
Overall height	minimum 905 mm	maximum 930 mm
Overall width	900 mm	
Overall depth	608 mm excluding handles, 669 mm including handles	
Minimum height above the hotplate	650 mm	

Hotplate energy saving tips

- Use cookware with a flat base.
- Use the correct size cookware.
- Use cookware with a lid.
- Minimise the amount of liquid or fat.
- When liquid starts boiling, reduce the setting.
- Consumption is based on G30.

Oven energy saving tips

- Cook meals together, if possible.
- Keep the pre-heating time short.
- Do not lengthen cooking time.
- Do not open the oven door during the cooking period.
- Do not forget to turn the appliance off at the end of cooking.

Professional FX 90 Dual Fuel

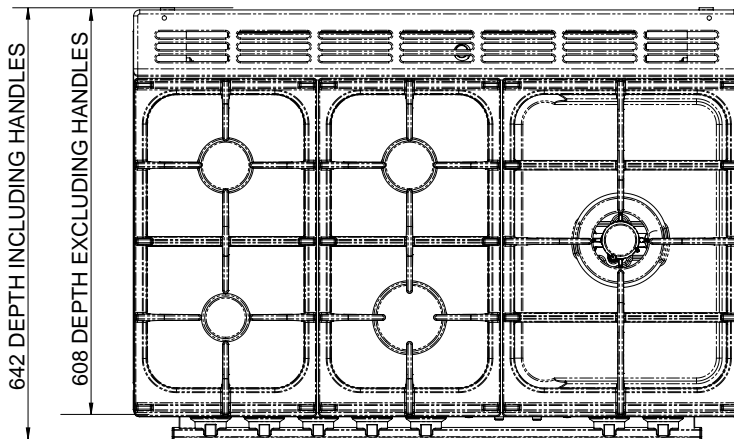
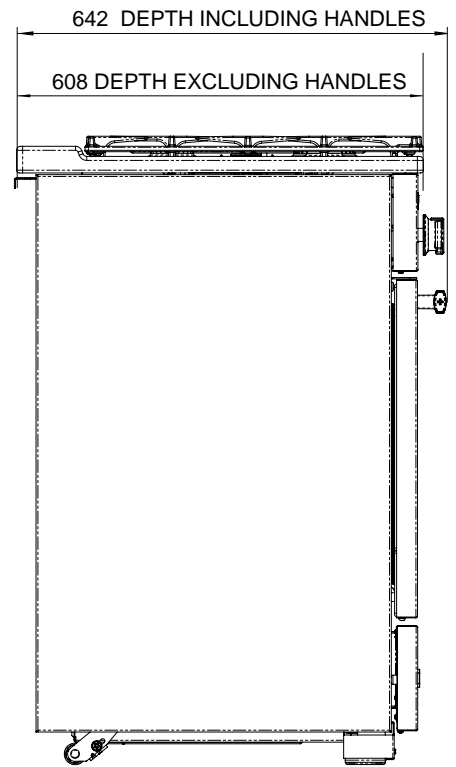
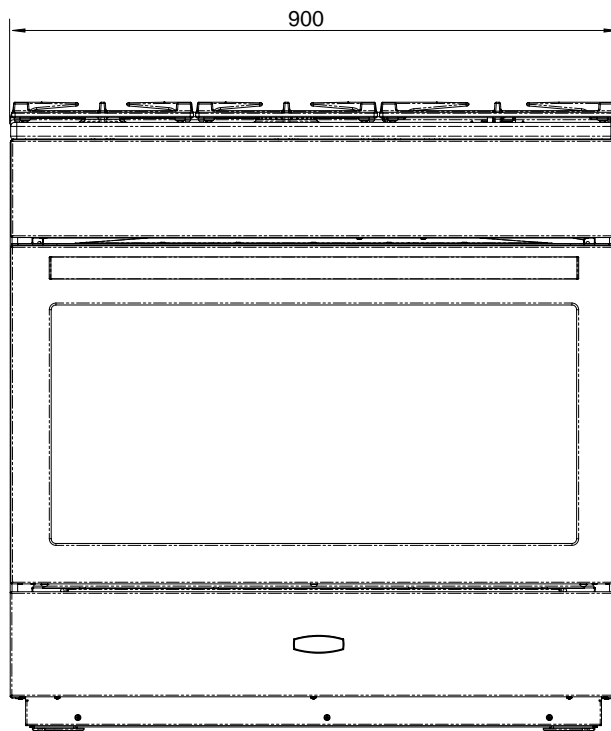

Classic FX 90 Dual Fuel

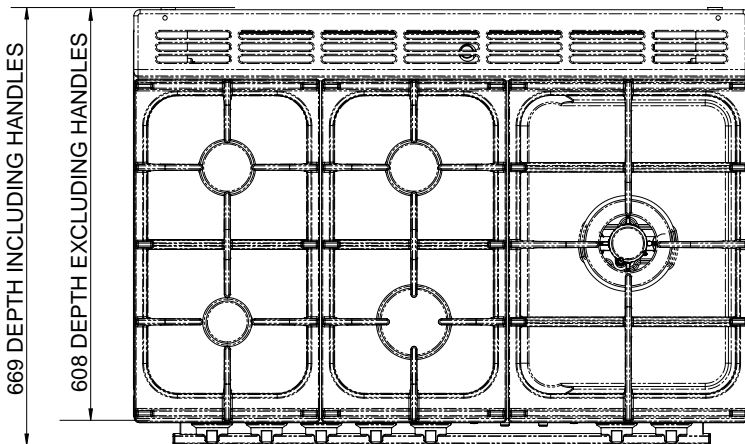
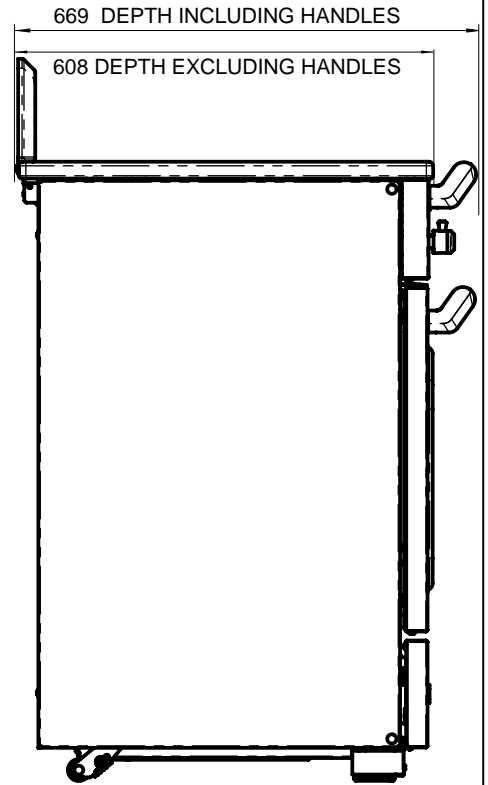
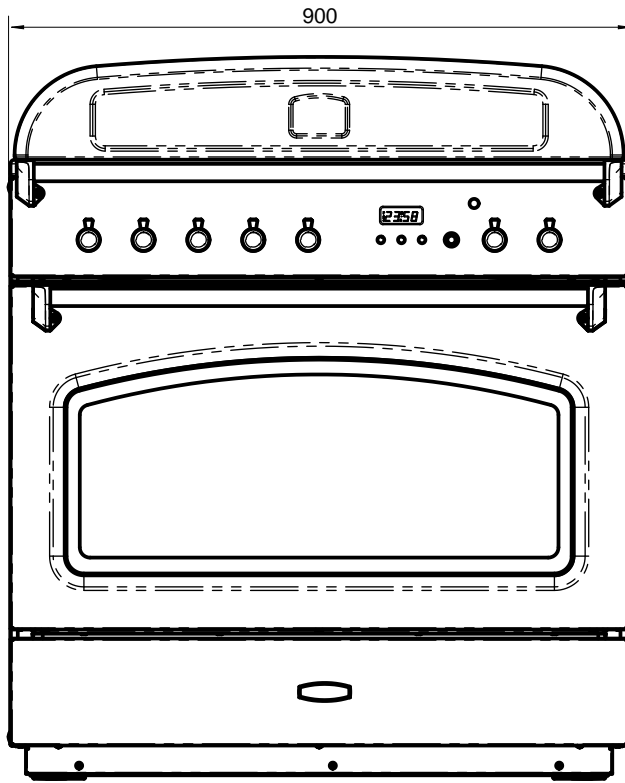

Hotplate efficiency

Brand	Falcon
Model Identification	Professional+ FX Classic FX
Size	90 Single Cavity
Type	Dual Fuel

Type of Hob	GAS
Number of gas burners	5
Auxiliary / Small Burner (EE gas burner)	-
Semi Rapide / Medium Burner (EE gas burner)	58%
Semi Rapide / Medium Burner (EE gas burner)	58%
Rapide / Large Burner (EE gas burner)	56%
Rapide / Large Burner (EE gas burner)	-
Wok (EE gas burner)	54%
Wok (EE gas burner)	-
Hotplate EE gas hob (*)	56%

Information marked thus (*) is not required with mixed fuel hobs

Oven data

Brand	Falcon	
Model identification	Professional+ FX Classic FX	
Type of oven	Electric	
Mass	kg	122
Number of cavities	1	
Single Cavity Efficiency		
Fuel type	Electric	
Cavity type *Drop Down Door	Multifunction*	
Power - conventional	2.75	
Power - forced air convection	3.3	
Volume	Litres	114
Energy consumption (electricity) - conventional	kWh / cycle	1.16
Energy consumption (electricity) - forced air convection	kWh / cycle	1.03
Energy efficiency index - conventional	112.8	
Energy efficiency index - forced air convection	93.9	
Energy class	A	

Additional Information		
The oven complies with EN 60350-1		
Maximum output @ 230V 50Hz	Full	Divided
Fan element	3.31 kW	1.65 kW
Top element	3.49 kW	1.75 kW
Browning element	2.11 kW	1.06 kW
Bottom element	1.38 kW	0.69 kW

Maximum total electrical load at 230 V (approximate total including hob, oven lights, oven fan, etc.)	3.60 kW
--	---------

Clarence Street, Royal Leamington Spa,
Warwickshire, CV31 2AD, England.
www.falconworld.com

CE
UK
RA