



# USER GUIDE & INSTALLATION INSTRUCTIONS

Nexus  
110 Dual Fuel / Steam

U111254-04s



# Contents

---

<b>1. Before You Start...</b>	<b>1</b>	<b>6. Cleaning Your Cooker</b>	<b>27</b>
Personal Safety	1	Essential Information	27
Electrical Connection Safety	1	Hotplate Burners	27
If You Smell Gas	3	Ceramic Hotplate	28
Peculiar Smells	3	The Griddle Plate	28
Cooling Fan	3	Grills	29
Ventilation	3	Multifunction Oven	30
Maintenance	3	Steam Cavity	31
Hob Care	6	Cleaning Table	32
Grill/Glide-out Grill™ Care	6	<b>7. Troubleshooting</b>	<b>33</b>
Cooker Care	6	<b>8. Installation</b>	<b>36</b>
Cleaning	7	Dear Installer	36
<b>2. Cooker Overview</b>	<b>8</b>	Safety Requirements and Regulations	36
Hotplate Burners	8	Provision of ventilation	36
Wok Burner	9	Location of cooker	36
The Wok Cradle	9	Conversion	36
The Ceramic Hotplate	10	Positioning the Cooker	38
The Griddle Plate	11	Moving the Cooker	38
The Glide-out Grill™ (Fig. 2.21)	11	Fitting the Stability Bracket or Chain	39
Bread Proving Drawer	12	Repositioning the Cooker Following Connection	39
Cleaning	13	Levelling	40
Telescopic runners ( <i>Left-hand oven</i> )	13	Gas Connection	40
<b>3. Using the Glide-out Grill™</b>	<b>14</b>	Electrical Connection	41
<b>4. The Multifunction Oven</b>	<b>15</b>	Final Checks	41
The Multifunction Oven ( <i>left-hand</i> )	15	Final Fitting	41
Operating the Multifunction Oven	15	Customer Care	41
Accessories	17	<b>9. Circuit Diagram</b>	<b>42</b>
The Handyrack ( <i>Optional extra</i> )	18	Power PCB	43
The Clock / Timer	18	<b>10. Technical Data</b>	<b>44</b>
Cooking Tips	20		
Cooking Table	21		
<b>5. The Steam Cavity</b>	<b>22</b>		
Operating the Steam Cavity	23		
Steam Cavity Functions	24		
Using the Steam Grill	24		
Program Modes	25		
The Clock / Timer	26		



# 1. Before You Start...

---

Your cooker should give you many years of trouble-free cooking if installed and operated correctly. It is important that you read this section before you start.

## Personal Safety

This appliance is for cooking purposes only. It must not be used for other purposes, for example heating a room. Using it for any other purpose could invalidate any warranty or liability claim. Besides invalidating claims this wastes fuel and may overheat the control knobs.

This cooker must be installed in accordance with the relevant instructions in this booklet and with the national and local regulations as well as the local gas and electricity supply companies' requirements.

- This appliance can be used by children aged from 8 years and above and persons with reduced physical, sensory or mental capabilities or lack of experience and knowledge if they have been given supervision or instruction concerning use of the appliance in a safe way and understand the hazards involved.
- **WARNING:** Children **less** than 8 years of age should be kept away unless continuously supervised. Children shall not play with the appliance. Cleaning and user maintenance shall not be made by children without supervision.
- The cooker should not be placed on a base.
- This appliance is designed for domestic cooking only. Use for any other purpose could invalidate any warranty or liability claim.
- Before operating the ovens please refer to the oven shelf installation, in the Accessories section.
- **WARNING:** The appliance and its accessible parts become hot during use and will retain heat even after you have stopped cooking. Care should be taken to avoid touching heating elements. Children less than 8 years of age shall be kept away unless continuously supervised.
- **CAUTION:** A long term cooking process has to be supervised from time to time. A short term cooking process has to be supervised continuously.
- At the risk of fire **DO NOT** store items on the cooking surfaces.
- To avoid overheating, **DO NOT** install the cooker behind a decorative door.
- **WARNING:** Accessible parts will become hot during use and will retain heat even after you have stopped cooking. Keep babies and children away from the cooker and never wear loose-fitting or hanging clothes when using the appliance.
- **DO NOT** use a steam cleaner on your cooker.
- Always keep combustible materials, e.g. curtains, and flammable liquids a safe distance away from the cooker.
- **DO NOT** spray aerosols in the vicinity of the cooker while it is on.

## Electrical Connection Safety

**⚠ WARNING: THE APPLIANCE MUST BE EARTHED.**

**Note:** The cooker must be connected to the correct electrical supply as stated on the voltage label on the cooker, through a suitable cooker control unit incorporating a double-pole switch, having a contact separation of at least 3 mm in all poles.

**⚠ The cooker MUST NOT be connected to an ordinary domestic power point.**

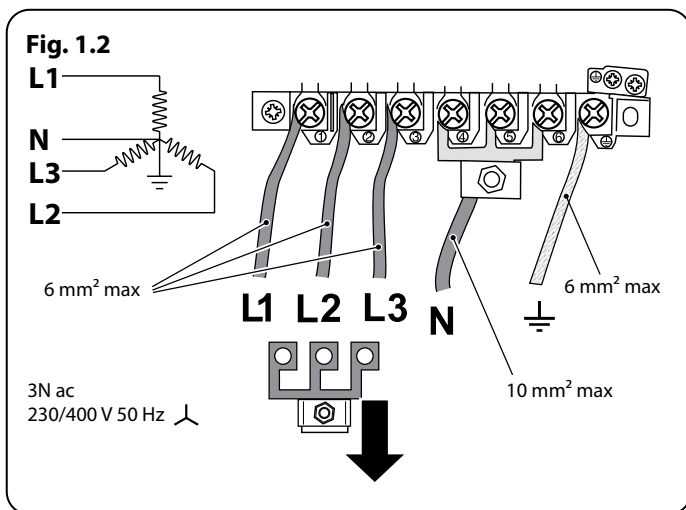
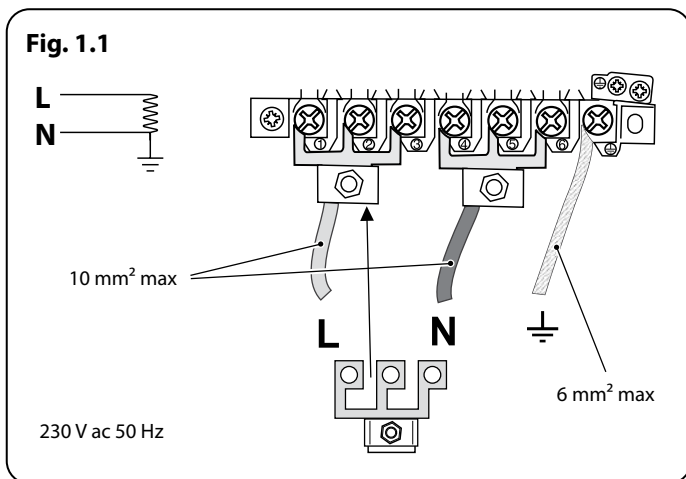

Access to the mains terminal is gained by removing the electrical terminal cover box on the back panel. Connect the mains cable to the correct terminals for your electrical supply type (**Fig. 1.1** and **Fig. 1.2**). Check that the links are correctly fitted and that the terminal screws are tight. Secure the mains cable using the cable clamp.

Minimum temperature rating T105. Read the instructions before installing or using this appliance.

## Gas Connection Safety

- This cooker is a Class 2 Subclass 1 appliance.
- This appliance can be converted for use on another gas.
- Before installation, make sure that the cooker is suitable for your gas type and supply voltage. See the data badge.
- DO NOT use reconditioned or unauthorised gas controls.
- Disconnect from the electricity and gas supply before servicing.
- When servicing or replacing gas-carrying components disconnect from the gas supply before starting operation. Check the appliance is gas sound after completion.
- Make sure that the gas supply is turned on and that the cooker is wired in and switched on.
- In your own interest and that of safety, it is law that all gas appliances be installed by a qualified person(s).
- An appliance for use on LPG must not be installed in a room or internal space below ground level, e.g. in a basement.

## If You Smell Gas

- **DO NOT** turn electric switches on or off
- **DO NOT** smoke
- **DO NOT** use naked flames
- Turn off the gas at the meter or cylinder
- Open doors and windows to get rid of the gas
- Keep people away from the area affected
- Call your gas supplier

## Peculiar Smells

When you first use your cooker it may give off an odour. This should stop after use.

Before using for the first time, make sure that all packing materials have been removed and then, to dispel manufacturing odours, turn the ovens to 200 °C and run for at least an hour.

Before using the grill for the first time you should also turn on the grill and run for 30 minutes with the grill pan in position, pushed fully back and the grill door open.

Make sure the room is well ventilated to the outside air (see 'Ventilation' below). People with respiratory or allergy problems should vacate the area for this brief period.

After the appliance has cooled, wipe down enamel and glass surfaces with a clean, lint free damp cloth.

## Cooling Fan

This appliance may have a cooling fan. When the grill or ovens are in operation the fan will run to cool the fascia and control knobs.

## Ventilation

The use of a cooking appliance results in the production of heat and moisture in the room in which it is installed. Therefore, make sure that the kitchen is well ventilated: keep natural ventilation holes open or install a powered cookerhood that vents outside. If you have

several hotplates/burners on, or use the cooker for a long time, open a window or turn on an extractor fan

## Maintenance

- It is recommended that this appliance is serviced annually.
- **WARNING:** Before replacing the bulb, turn off the power supply and make sure that the oven is cool.
- **DO NOT** use cooking vessels on the hotplate that overlap the edges.
- Unless specified otherwise in this guide, always allow the cooker to cool and then switch it off at the mains before cleaning or carrying out any maintenance work.
- **DO NOT** use the control knobs to manoeuvre the cooker.
- **NEVER** operate the cooker with wet hands.
- **DO NOT** use a towel or other bulky cloth in place of a glove – it might catch fire if brought into contact with a hot surface.
- **DO NOT** use hotplate protectors, foil or hotplate covers of any description. These may affect the safe use of your hotplate burners and are potentially hazardous to health.
- **NEVER** heat unopened food containers. Pressure build up may make the containers burst and cause injury.
- **WARNING:** Use only hob guards designed by the manufacturer of the cooking appliance or indicated by the manufacturer of the appliance in the instructions for use as suitable or hob guards incorporated in the appliance. The use of inappropriate guards can cause accidents.
- **DO NOT** use unstable saucepans. Always make sure that you position the handles away from the edge of the hotplate.

- **NEVER** leave the hotplate unattended at high heat settings. Pans boiling over can cause smoking, and greasy spills may catch on fire. Use a deep fat thermometer whenever possible to prevent fat overheating beyond the smoking point.

**⚠ WARNING: Unattended cooking on a hob with fat or oil can be dangerous and may result in fire.**

- **NEVER** try to extinguish a fire with water, but switch off the appliance and then cover the flame e.g. with a lid or a fire blanket.
- **NEVER** leave a chip pan unattended. Always heat fat slowly, and watch as it heats. Deep fry pans should be only one third full of fat.
- **WARNING: Danger of fire: do not store items on the cooking surfaces.**
- **NEVER** try to move a pan of hot fat, especially a deep fat fryer. Wait until the fat is cool. Filling the pan too full of fat can cause spill over when food is added. If you use a combination of oils or fats in frying, stir them together before heating, or as the fats melt.
- Foods for frying should be as dry as possible. Frost on frozen foods or moisture on fresh foods can cause hot fat to bubble up and over the sides of the pan. Carefully watch for spills or overheating of foods when frying at high or medium high temperatures.
- **DO NOT** use the top of the flue (the slot along the back of the cooker) for warming plates, dishes, drying tea towels or softening butter.
- **DO NOT** use water on grease fires and never pick up a flaming pan. Turn the controls off and then smother a flaming pan on a surface unit by covering the pan completely with a well fitting lid or baking

tray. If available, use a multi-purpose dry chemical or foam-type fire extinguisher.

- **DO NOT** modify this appliance. This appliance is not intended to be operated by means of external timer or separated remote-control system.
- If flammable materials are stored in the drawer, oven(s) or grill(s) it may explode and result in fire or property damage.

## Oven Care

- When the oven is not in use and before attempting to clean the cooker always be certain that the control knobs are in the **OFF** position.
- Use oven gloves to protect your hand from potential burns.
- Cooking high moisture content foods can create a 'steam burst' when the oven door is opened (**Fig. 1.3**). When opening the oven, stand well back and allow any steam to disperse.
- The inside door face is constructed with toughened safety glass. Take care **NOT** to scratch the surface when cleaning the glass panel.
- Accidental damage may cause the door glass panel to fracture.
- Keep oven vent ducts unobstructed.
- **DO NOT** use harsh abrasive cleaners or sharp metal scrapers to clean the oven door glass since they can scratch the surface, which may result in shattering of the glass.
- Make sure the shelves are pushed firmly to the back of the oven. **DO NOT** close the door against the oven shelves.
- **DO NOT** use aluminium foil to cover shelves, linings or the oven roof.
- When the oven is on, **DO NOT** leave the oven door open for longer than necessary, otherwise the control knobs may become very hot.



- **DO NOT** use the timed oven if the adjoining oven is already warm.
- **DO NOT** place warm food in the oven to be timed.
- **DO NOT** use a timed oven that is already warm.
- Use dry oven gloves when applicable – using damp gloves might result in steam burns when you touch a hot surface.

## Oven Shelves

To fit the glide-out shelf, hook the front of the shelf onto the runners as shown (**Fig. 1.4**). The rear of the shelf should rest on the runners, in front of the rear stop (**Fig. 1.4**).

Steam oven shelves can be fitted by lining up the shelf with a groove in the oven ladders. Push the shelf back until the ends hit the shelf stop. Lift the front so the shelf clears the stops, then lower the front so the shelf is level and push it fully back.

## Warming Zone Care

- **NEVER** attempt to cook directly on the heating zone.
- **DO NOT** use the heating zone surface as a cutting board.
- **DO NOT** leave utensils, foodstuff or combustible items on the heating zone when it is not in use (e.g. tea towels, frying pans containing oil).
- **DO NOT** place plastic or aluminium foil, or plastic containers, on the heating zone.
- **DO NOT** leave the heating zone switched on unless being used for warming.
- **DO NOT** stand or rest heavy objects on the heating zone.

Although the ceramic surface is very strong, a sharp blow or sharp falling object (e.g. a salt cellar) might cause the surface to crack or break (**Fig. 1.5**)

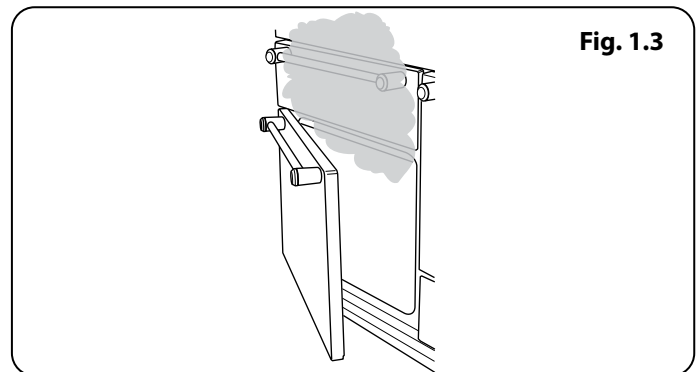

Fig. 1.3

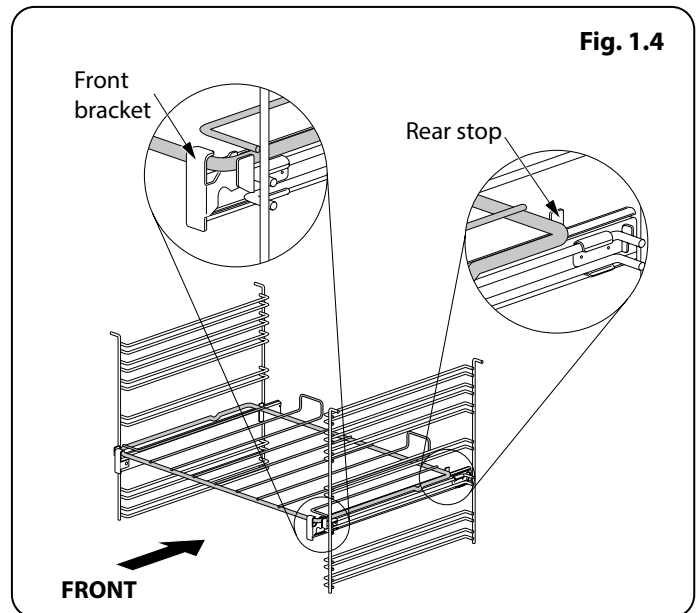

Fig. 1.4

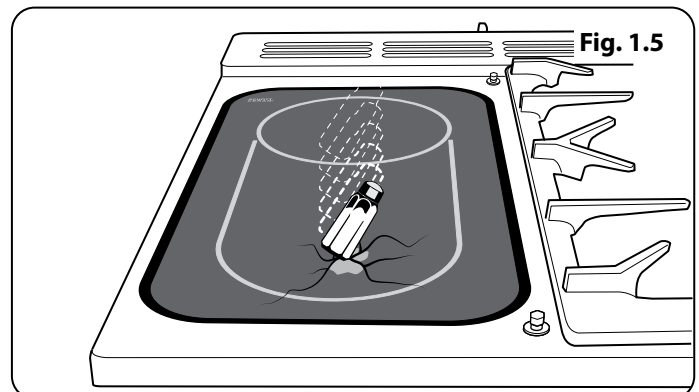

Fig. 1.5

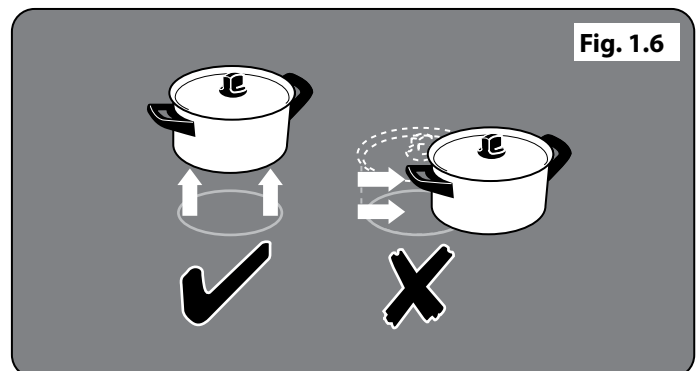

Fig. 1.6

**⚠ WARNING:** If the surface is cracked, switch off the appliance to avoid the possibility of electric shock.

**⚠ WARNING:** Should a crack appear in the surface, disconnect the cooker immediately from the supply and arrange for its repair.

Always LIFT pans off the heating zone. Sliding pans may cause marks and scratches (**Fig. 1.6**). Always turn the control to the 'OFF' position before removing a pan.

- **DO NOT** place anything between the base of the pan and the heating zone surface (e.g. asbestos mats, aluminium foil, wok cradle).
- Take care **NOT** to place metallic objects such as knives, forks, spoons and lids on the hob surface since they can get hot.
- The appliance is not intended to be operated by means of external timer or separated remote-control system.
- Avoid warming an empty pan. Doing so may damage both the heating zone and pan.

Only certain types of glass, glass-ceramic, earthenware or other glazed containers are suitable for use on the heating zone; others may break because of the sudden change in temperature.

## Hob Care

- **NEVER** allow anyone to climb or stand on the hob.
- **DO NOT** use the hob surface as a cutting board.
- **DO NOT** leave utensils, foodstuffs or combustible items on the hob when it is not in use (e.g. tea towels, frying pans containing oil).
- **DO NOT** place plastic or aluminium foil, or plastic containers on the hob.
- Always turn the control to the **OFF** position before removing a pan.
- Avoid heating an empty pan. Doing so may damage both the hob and pan.

## Grill/Glide-out Grill™ Care

- When using the grill, make sure that the grill pan is in position and pushed fully in, otherwise the control knobs may become very hot.
- **DO NOT** leave the grill on for more than a few moments without the grill pan underneath it, otherwise the knobs may become hot.
- **NEVER** close the grill door when the grill is on.
- Accessible parts may be hot when the grill is in use. Young children should be kept away

## Cooker Care

As steam can condense to water droplets on the cool outer trim of the oven, it may be necessary during cooking to wipe away any moisture with a soft cloth. This will also help to prevent soiling and discolouration of the oven exterior by cooking vapours.

## Cleaning

- Isolate the electricity supply before carrying out any thorough cleaning. Allow the cooker to cool.
- In the interests of hygiene and safety, the cooker should be kept clean at all times as a build up in fats and other food stuff could result in a fire.
- Clean only the parts listed in this guide.
- Clean with caution. If a wet sponge or cloth is used to wipe spills on a hot surface, be careful to avoid steam burns. Some cleaners can produce noxious fumes if applied to a hot surface.
- **NEVER** use paint solvents, washing soda, caustic cleaners, biological powders, bleach, chlorine based bleach cleaners, coarse abrasives or salt.
- **DO NOT** mix different cleaning products – they may react together with hazardous results.
- All parts of the cooker can be cleaned with hot soapy water.
- Take care that no water seeps into the appliance.
- Before you remove any of the grill parts for cleaning, make sure that they are cool or use oven gloves.
- **DO NOT** use any abrasive substances on the grill and grill parts.
- **DO NOT** put the side runners in a dishwasher.
- **DO NOT** put the burner heads in a dishwasher.
- **NEVER** use caustic or abrasive cleaners as these will damage the surface.
- **DO NOT** use steel wool, oven cleaning pads or any other materials that will scratch the surface.
- **NEVER** store flammable materials in the drawer. This includes paper, plastic and cloth items, such as cookbooks, plastic ware and towels, as well as flammable liquids.
- **DO NOT** store explosives, such as aerosol cans, on or near the appliance.
- **DO NOT** use steel wool, oven cleaning pads, or any other materials that will scratch the surface.
- **DO NOT** attempt to disassemble or clean around any burner while another burner is on, otherwise an electric shock could result.

## 2. Cooker Overview

Fig. 2.1

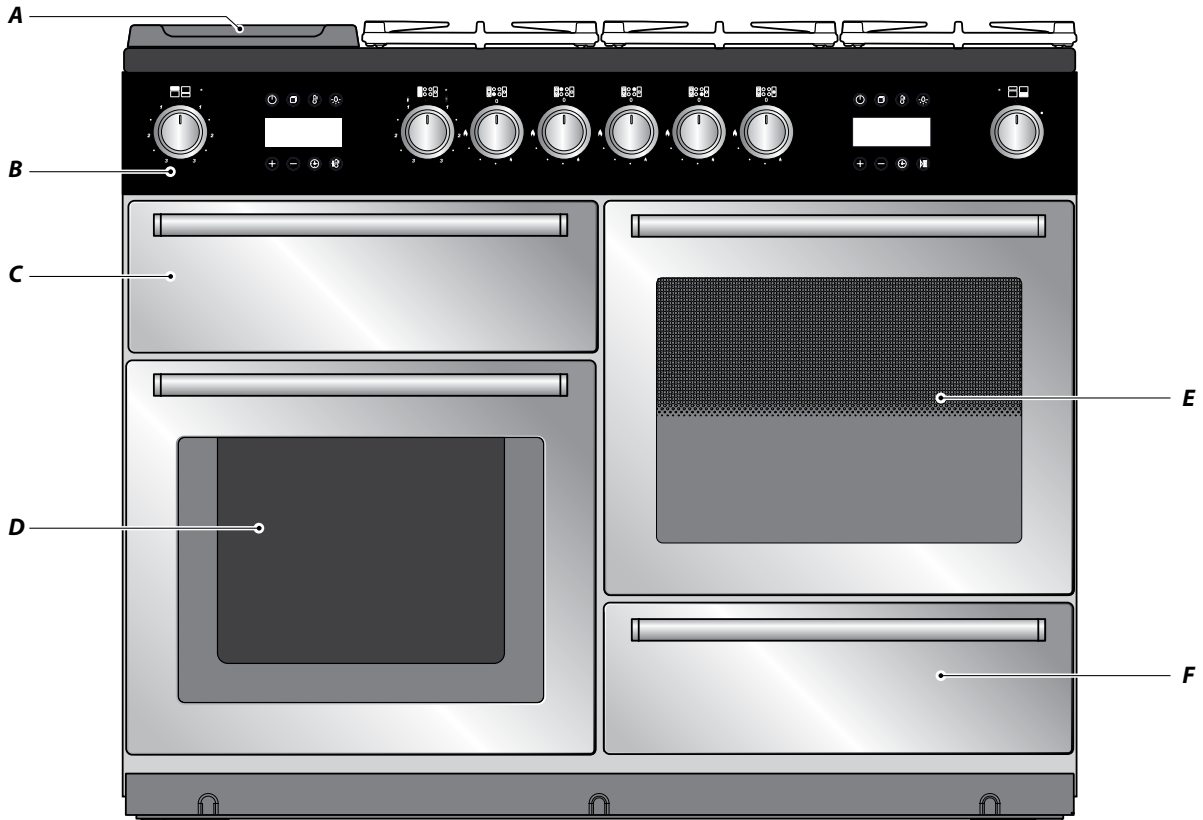
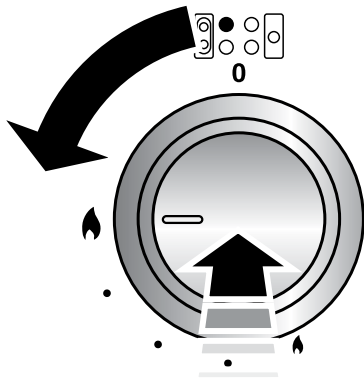

Fig. 2.2



The 110 dual fuel cooker (**Fig. 2.1**) has the following features:

- A. 4 hotplate burners, a Wok Burner and a Ceramic Multizone hotplate
- B. Control Panel
- C. Glide-out Grill™ with 4 position Trivet
- D. Multifunction Oven
- E. Steam cavity
- F. Bread Proving/Storage Drawer

### Hotplate Burners

The labels by each of the control knobs indicates which area that knob controls.

Each burner has a Flame Supervision Device (FSD) that prevents the flow of gas if the flame goes out.

**When a hotplate control knob is pressed in, sparks will be made at every burner – this is normal. Do not attempt to disassemble or clean around any burner while another burner is on, otherwise an electric shock could result.**

To light a burner, push in and turn the associated control knob to the high position as indicated by the large flame symbol (🔥), (**Fig. 2.2**).

The igniter should spark and light the gas. Continue to press in the knob to let the gas through to the burner for about ten seconds.

If and when you let go of the control knob or the burner goes out, then the FSD has not been bypassed. Turn the control knob to the OFF position and wait for one minute before you try again, this time making sure to hold in the control knob for slightly longer.

Adjust the flame height to suit by turning the knob counter-clockwise (**Fig. 2.3**). On this cooker the low position is beyond high, **NOT** between high and off.

If a burner flame goes out, turn off the control knob and leave it for one minute before relighting it.

Make sure that the flames are under the pans. Using a lid will help the contents boil more quickly (**Fig. 2.4**).

Large pans should be spaced well apart.

Pans and kettles with concave bases or down-turned base rims should not be used (**Fig. 2.5**).

Simmering aids, such as asbestos or mesh mats, are **NOT** recommended (**Fig. 2.6**). They will reduce burner performance and could damage the pan supports.

You should also avoid using unstable and misshapen pans that may tilt easily, and pans with a very small base diameter, e.g. milk pans, single egg poachers (**Fig. 2.7**).

The minimum recommended pan diameter is 120 mm. The maximum allowable pan base diameter is 260 mm.

**DO NOT** use cooking vessels on the hotplate that overlap the edges.

## Wok Burner

The Wok Burner is designed to provide even heat over a large area. It is ideal for large pans and stir-frying (**Fig. 2.8**).

For heating smaller pans, the aforementioned hotplate burners may be more efficient.

You should wipe the enamel top surface of the cooker around the hotplate burners as soon as possible after spills occur. Try to wipe them off while the enamel is still warm.

**NOTE:** The use of aluminium pans may cause metallic marking of the pan supports. This does not affect the durability of the enamel and may be cleaned off with a suitable metal cleaner.

## The Wok Cradle

The Wok Cradle is designed to fit a 35 cm wok. If you use a different wok, make sure that it fits the cradle. Woks vary very widely in size and shape. It is important that the wok sits down on the pan support – however, if the wok is too small, the cradle will not support it properly (**Fig. 2.9**).

The cradle should be used on the wok burners only. When you fit the cradle, check that it is supported properly on a pan support and that the wok is sitting level in the cradle (**Fig. 2.10**).

The cradle will get very hot in use – allow plenty of time for it to cool before you pick it up.

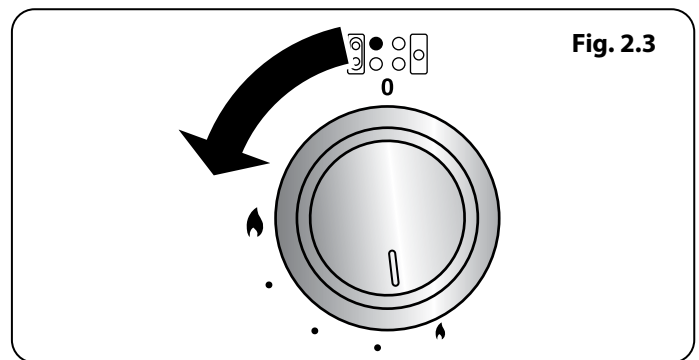

Fig. 2.3

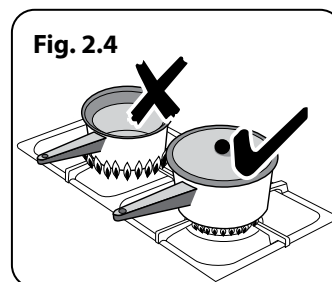

Fig. 2.4

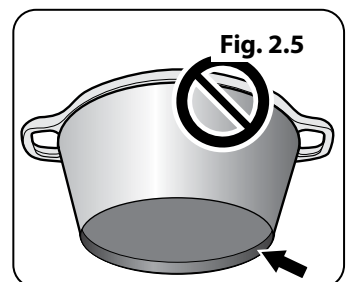

Fig. 2.5

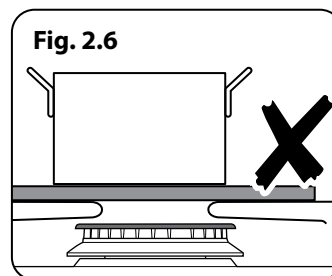

Fig. 2.6

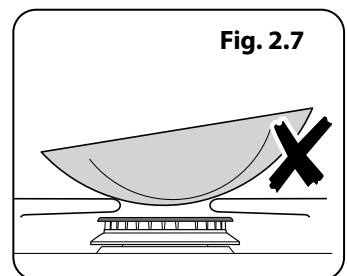

Fig. 2.7

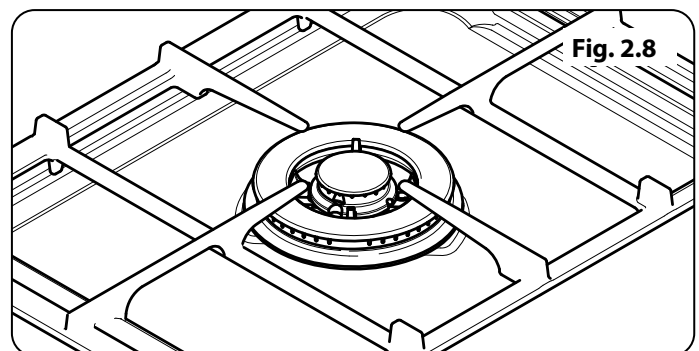

Fig. 2.8

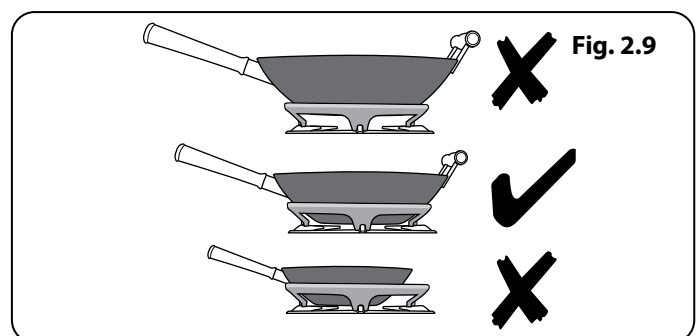

Fig. 2.9

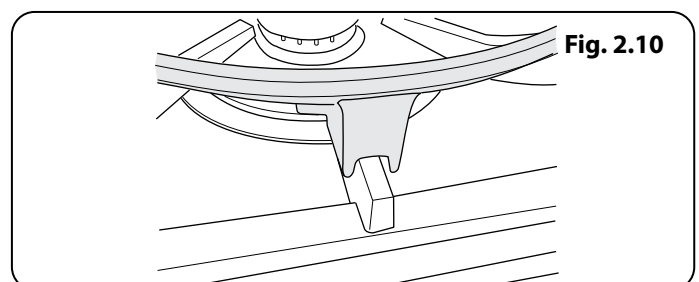

Fig. 2.10

Fig. 2.11

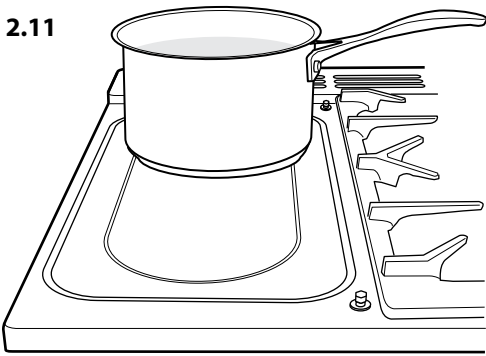

Fig. 2.12

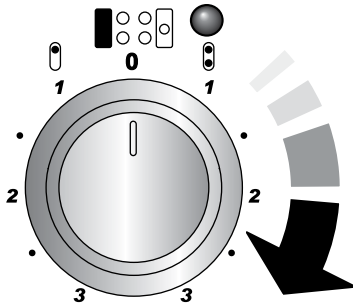

Fig. 2.13

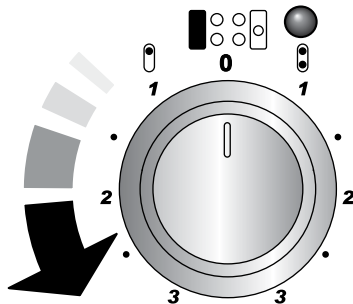

Fig. 2.14

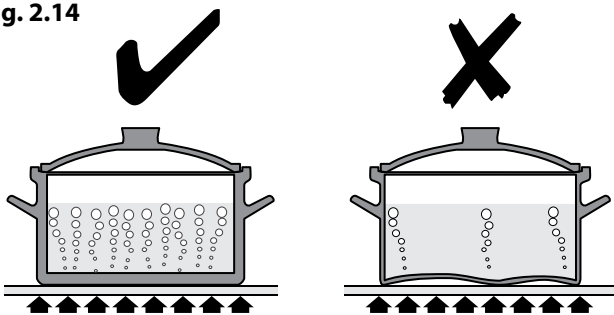
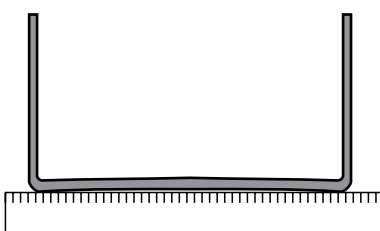

Fig. 2.15



## The Ceramic Hotplate

The hotplate area on the left-hand side is dual purpose. It can be used either as a ceramic hob to heat a pan in the usual way (**Fig. 2.11**) or it can be used to heat the supplied griddle plate.

The rear area, marked with a ring, is for cooking with a pan.

There are two elements that allow either the whole of the area to be heated or just the rear half.

To heat the whole area, turn the hotplate control clockwise (**Fig. 2.12**).

To use the rear ring only, turn the hotplate control counter-clockwise (**Fig. 2.13**).

The neon indicator light above the control knob will come on when the hotplate control is turned on and stay lit while the surface cools.

You can also place a large fish kettle across both heating zones.

Always take care before touching the surface even when it is turned off – it may be hotter than you think.

Use only pans that are suitable for ceramic hobs.

We recommend stainless steel and enamelled steel pans because pots and pans with copper or aluminium bases leave traces on the hob that are difficult to remove.

Pots and pans should have thick, smooth, flat bottoms (**Fig. 2.14**). This makes sure the maximum heat transfer from the hob to the pan, making cooking quick and energy efficient. Never use a round-bottomed wok, even with a stand.

The very best pans have bases that are very slightly curved up when cold. If you hold a ruler across the bottom you will see a small gap in the middle (**Fig. 2.15**). When they heat up the metal expands and lies flat on the cooking surface.

Make sure that the base of the pan is clean and dry to prevent any residue burning onto the hob panel. This also helps prevent scratches and deposits.

Always use pans that are the same size as (or slightly larger than) the areas marked on the hob top (**Fig. 2.16**). Using smaller pans wastes heat, and any spillage will be burnt on. Using a lid will help the contents boil more quickly.

Always lift pans off the hob. Sliding pans may cause marks and scratches. Always turn the control to the 'OFF' position before removing a pan.

When cooking on the hob you may see the hob area you are using switch off and on. This is caused by a safety device that limits the temperature of the hob. It is quite normal, especially when cooking at high temperatures. If it happens a lot with a particular pan however it may mean the pan is not suitable – perhaps too small or too uneven – for a ceramic hob.

For best results, preheat a covered serving dish for 10 minutes before adding food to it.

Use only heat-resistant dishes.

## The Griddle Plate

The griddle plate (**Fig. 2.17**) is designed to fit securely on the locating pins over the ceramic heating area (**Fig. 2.18**). **DO NOT** try to use it over one of the gas burners. It will not be securely held and you may damage the non-stick finish.

To heat the whole area, turn the hotplate control clockwise (**Fig. 2.19**).

The neon indicator light above the control knob will come on when a hob control is turned on and stay lit while the surface cools.

It is designed for cooking food on directly. **DO NOT** use pans of any kind on it. The griddle plate surface is non-stick and metal cooking utensils (e.g. spatulas) will damage the surface. Use heat resistant plastic or wooden utensils.

The griddle plate can be lightly brushed with cooking oil before use.

Preheat the griddle plate for **a maximum of 5 minutes** before adding food. Leaving it longer may cause damage.

There is a gap at the right-hand rear corner of the griddle plate (**Fig. 2.20**) so you can pour off excess fat after cooking.

**⚠ Be careful – it may be very hot.**

After cooking, allow the griddle plate to cool before cleaning.

## The Glide-out Grill™ (Fig. 2.21)

**⚠ WARNING: When the trivet has been removed from the grill pan, please ensure that the grill pan and cradle are fully returned into the grill chamber. The grill pan door MUST remain open.**

**⚠ Accessible parts may be hot when the broiler is in use. Young children should be kept away.**

**⚠ Never close the grill door when the grill is on.**

1. For best results, slide the carriage back into the grill chamber. The grill trivet can be removed and the food placed on it while you are waiting for the grill to preheat.
2. **DO NOT** leave the grill on for more than a few moments without the grill pan underneath it, otherwise the knobs may become hot.
3. Once the grill has preheated, slide the carriage out again. With the trivet back in place with the food on it, slide the carriage back into the grill chamber. Make sure that it is pushed right in.

The grill pan trivet can be turned to give four grilling heights by a combination of turning it back to front and turning it upside down. See chapter **Using the Glide-out Grill™**.

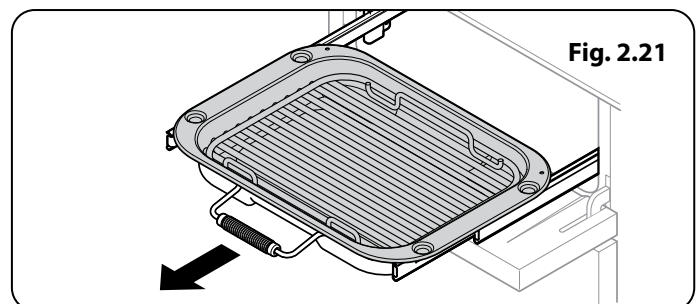
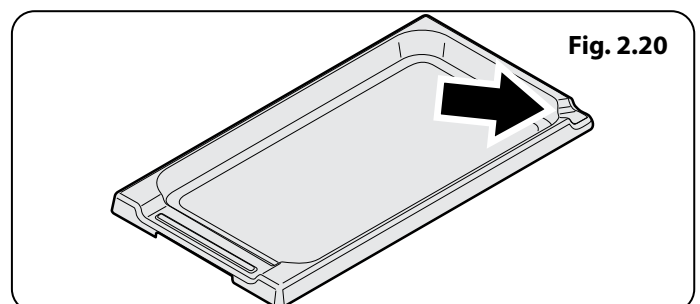
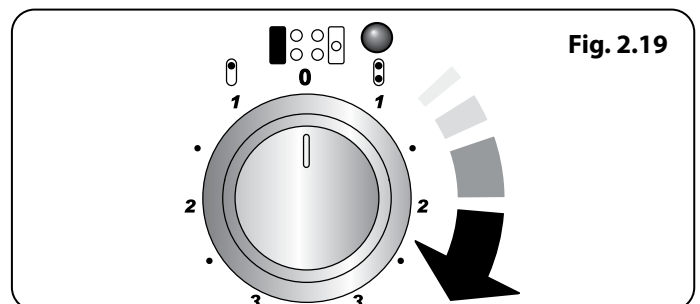
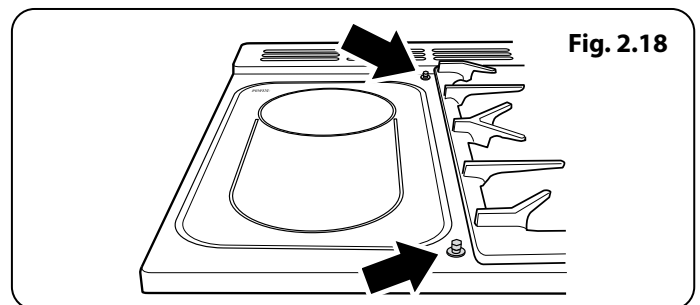
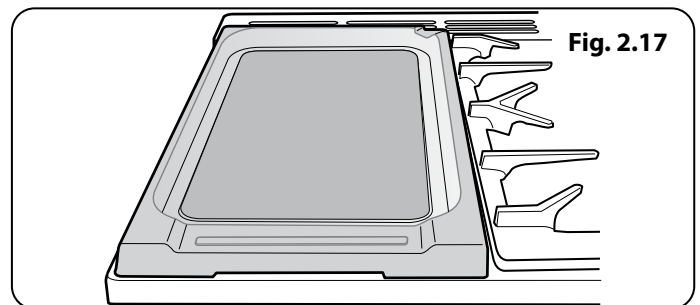
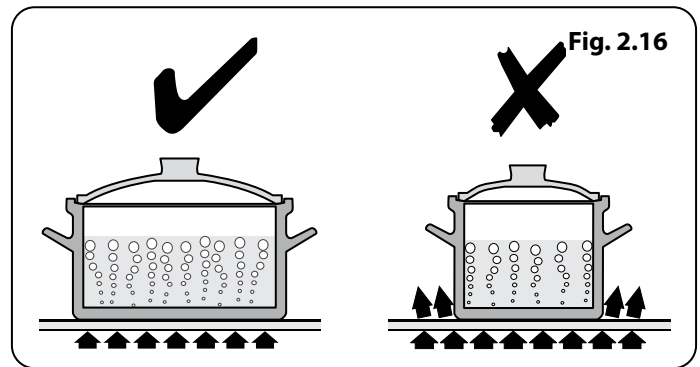

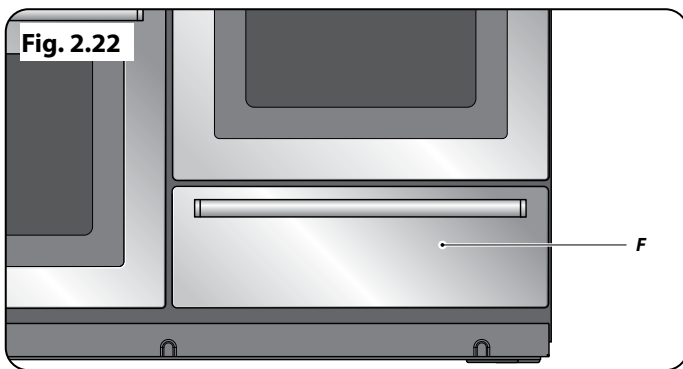

## Bread Proving Drawer

The Bread Proving Drawer is found on the right at the base of the cooker (**Fig. 2.22**). Within the Bread Proving Drawer there are slots in the base to allow warmed air to flow through into the drawer from the element underneath.

The Bread Proving Drawer temperature is ideal for proving all sorts of yeast dough from sweet to savoury, gluten free to sourdough, dough made from fresh yeast and dried, bread mixes and recipes from the Rangemaster Good Housekeeping Cookery book.

Pre-heat the drawer so that it is warm and ready for your dough.

Turn the knob clockwise (**Fig. 2.23**). There is no need to set the temperature, this is already set.

The Bread Proving Drawer has space for:

- Baking trays, no larger than 340mm x 340mm, to prove bread rolls or buns; these can then be put straight into a preheated oven after proving.
- To prove 2 trays at once in the drawer use a cooling rack or trivet over the top of one tray with the other on top, remember to allow space for the dough to expand during the proving time.
- 3 litre bowl full of dough
- 3 x 2 pound loaf tins
- 4 x 1 pound loaf tins

The time needed for proving will depend upon the dough type and the amount. Refer to the recipe for guidance and check the dough during the proving time.

If a large baking tray is used, place a cooling rack on to the base of the drawer, and put the tray on top, this will allow the warmed air to reach the dough.

When preparing larger quantities of yeast dough, containing 500g or over of flour, divide the dough into 2 bowls or containers, this will make proving in the drawer easier.

Keep an eye on the dough while it is proving; fresh yeast can work quickly especially if it has had a first fermentation stage (sometimes called sponging). Sponging can help produce a slightly lighter loaf.

### TOP TIPS

Not sure of the capacity of your loaf tins?

- A one pound loaf tin will hold 800ml of water
- A two pound loaf tin will hold 1.5 litres of water.
- Cover the dough while it is proving with greased cling film, be careful not to anchor the cling film too tightly so that it prevents the dough from rising.

The Bread Proving Drawer can be used for storage. If you have used the Bread Proving Drawer, switch it off and wait until the drawer cools before storing any items.

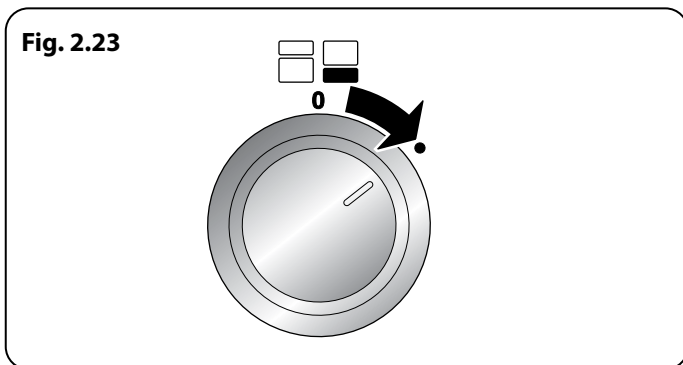



## Cleaning

Clean the inside of the drawer with hot soapy water and a soft cloth, rinse and dry.

The Bread Proving Drawer is ideal for storing baking trays and other cooking utensils.

It can get warm, so do not store anything in it that may melt or catch fire.

- ⚠ **Never store flammable materials in the drawer. This includes paper, plastic and cloth items, such as cookbooks, plastic ware and towels, as well as flammable liquids.**
- ⚠ **Do not store explosives, such as aerosol cans, on or near the appliance.**
- ⚠ **Flammable materials may explode and result in fire or property damage.**

## Telescopic runners *(Left-hand oven)*

A glide-out oven shelf is available for the left-hand oven (**Fig. 2.24**).

**Note:** The Handyrack must be removed before fitting the glide-out shelf.

The rungs on the shelf supports are in pairs. The glide-out shelf runners can be fitted to any pair except the top.

### To fit the glide-out shelf runners

Hook the rear of the runner over the top rung of a pair of shelf supports. Then hook the front of the runner onto the same rung. Push to clip under the bottom rung (**Fig. 2.25**).

The front of the shelf runners can be identified by the bracket (**Fig. 2.27**).

Ensure that the shelf runners are fitted in the same position on each side (**Fig. 2.26**).

### To fit the glide-out shelf

Check the shelf runners are secure before fitting the glide-out shelf.

Hook the front of the glide-out oven shelf onto the runners as shown (**Fig. 2.27**). The rear of the shelf should rest on the runners, in front of the rear stop (**Fig. 2.27**).

Ensure that the shelf sits flat once in position.

- ⚠ **DO NOT put the glide-out shelf runners in a dishwasher**

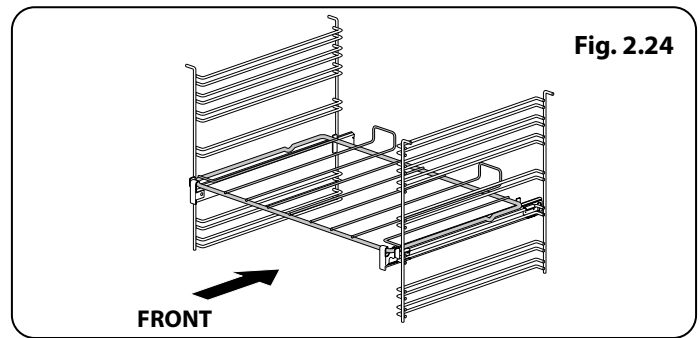

Fig. 2.24

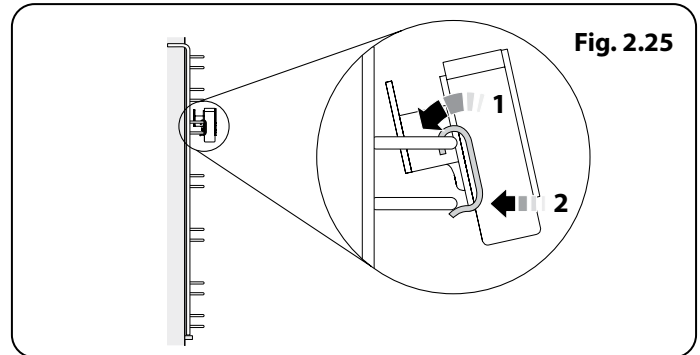

Fig. 2.25

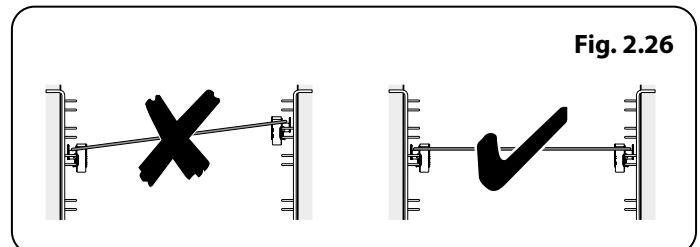

Fig. 2.26

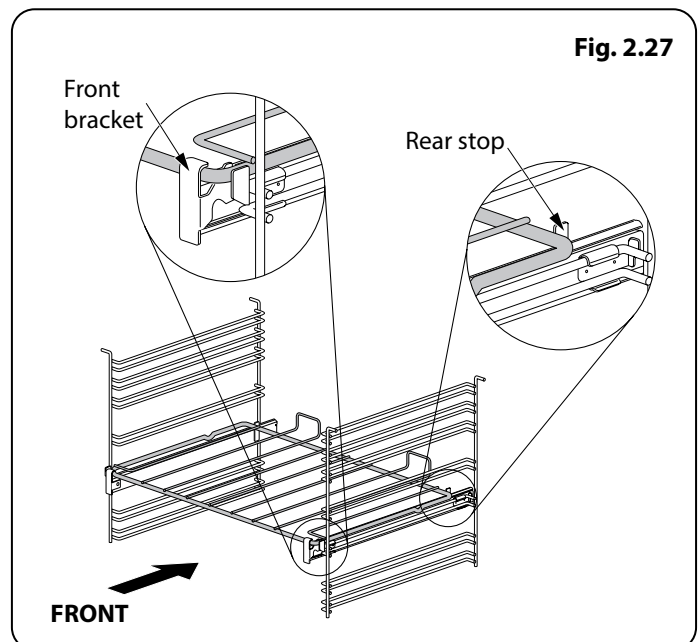

Fig. 2.27

### 3. Using the Glide-out Grill™

Fig. 3.1

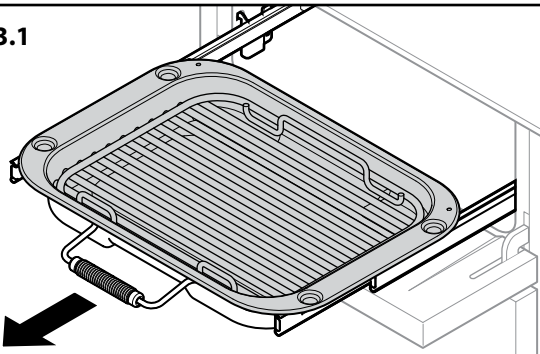
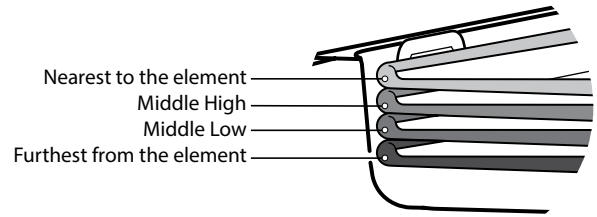
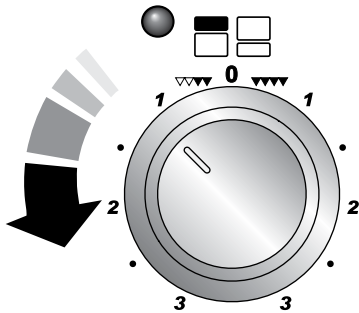

Fig. 3.2



Four grill height positions refer to Fig. 3.5

Fig. 3.3



To switch on the right half element

Fig. 3.4

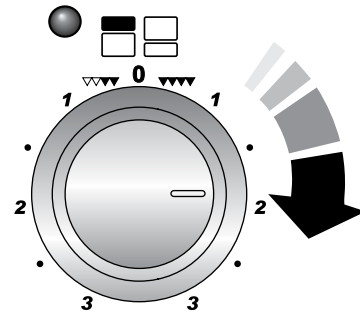

To switch on both elements

Four grill height positions

Fig. 3.5

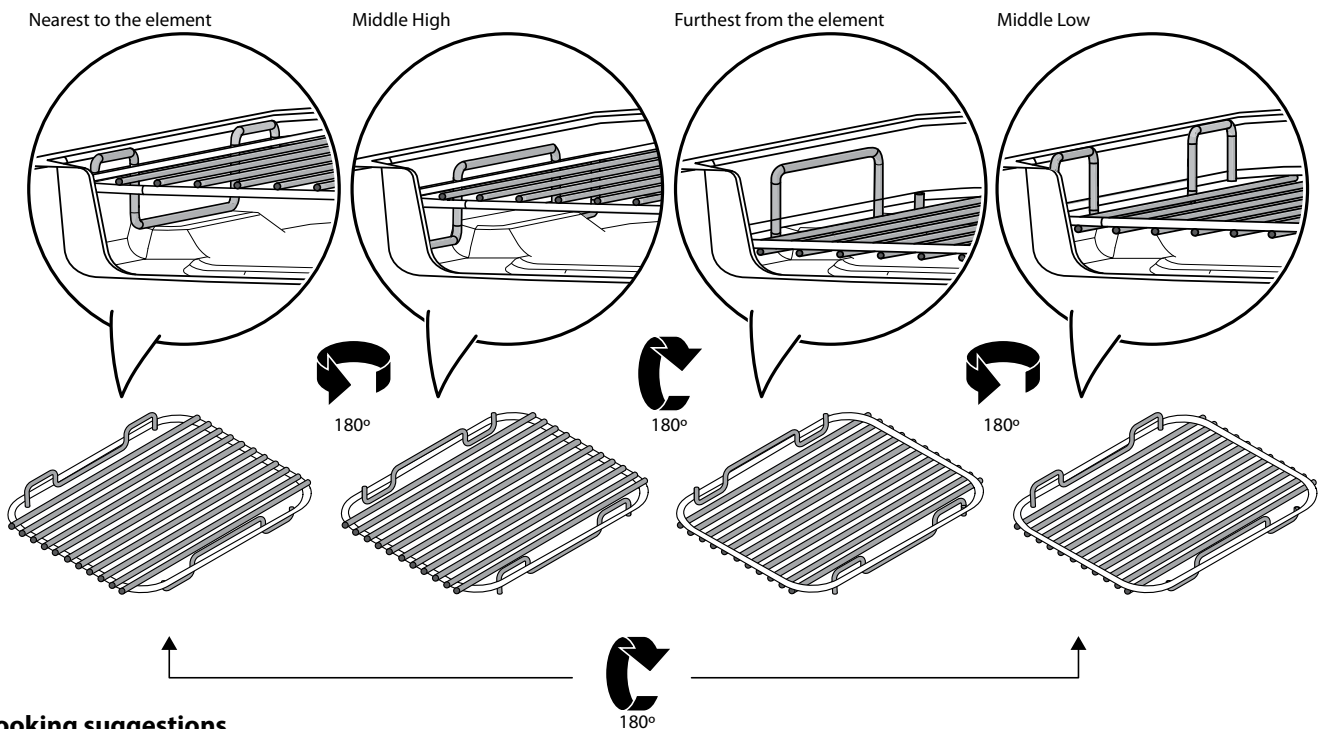

#### Cooking suggestions

1. Nearest to the element – Toast, streaky bacon.
2. Middle high – cheese on toast, welsh rarebit, courgette slices, back bacon.
3. Middle low – fish fillets, vegetable skewers.
4. Furthest from the element – whole fish, thick pork chops, chicken breasts, chicken or beef skewers.

**NOTE:** A short term cooking process has to be supervised continuously.

## 4. The Multifunction Oven

The clock must be set to the time of day before the oven will work. See the section on 'The Clock' for instructions on setting the time of day.

**References to 'left-hand' and 'right-hand' ovens apply as viewed from the front of the appliance.**

The left-hand oven is a multifunction oven, while the right-hand is a steam cavity.

### The Multifunction Oven *(left-hand)*

As well as the oven fan and fan element, multifunction ovens are fitted with two extra heating elements, one visible in the top of the oven and the second under the oven base. Take care to avoid touching the top element and element deflector when placing or removing items from the ovens.

**Table 4.1** gives a summary of the multifunction modes.

The multifunction oven has many varied uses. We suggest you keep a careful eye on your cooking until you are familiar with each function. Remember, not all functions will be suitable for all food types.

### Operating the Multifunction Oven

**Fig. 4.1** shows the left hand, touch sensitive control panel, for the multifunction oven.

#### To select a cooking function

Touch and hold the "Standby" button (1). The display will show the fan oven mode and a temperature setting of 180°C. The oven will start cooking in this mode after 5 seconds.

The oven light will turn on for 2 minutes and then go off. The oven light can be turned off at any time by tapping button (4).

To change the cooking function touch and hold the "Mode" button (2) until the cooking symbol begins to flash.

Change the cooking function using the [+ ] or [- ] buttons (5 or 6). The oven will start cooking after 5 seconds.

**Note:** Cycling through the oven functions will re-set the oven temperature to the default 180°C.

#### To adjust cooking temperature

Touch and hold the "Temperature" button (3) until the display begins to flash.









Select your desired temperature using the [+ ] or [- ] buttons (5 or 6). The oven will start to cook at the new temperature after 5 seconds.

If a lower cooking temperature is chosen there will be a time period required for the cavity to cool down.

**Note:** Tap the "Temperature" button during cooking to display the current temperature in the oven cavity.

#### To turn the Multifunction oven off

The multifunction oven is turned off by tapping the "Standby/On" button (1).

Symbol	Function	Use
	Fan	A full cooking function, even heat throughout, great for baking
	Duo	Gentle form of heating using base heat and fan. Suitable for pastries, cakes and open tarts, for example, quiches
	Conventional	A full cooking function for roasting and baking in the lower half of the oven
	Base heat	To crisp up the bases of quiche, pizza or pastry
	Grill	This function radiates the heat from the grill element
	Fanned grilling	Grilling meat and fish with the door closed
	Fan assisted	A full cooking function good for roasting and baking
	Delicate	To cook delicate items; creme brulee, blind baking, bain marie
ECO	ECO mode	Energy saving function for foods requiring 45 minutes or less
	Defrost	To thaw small items in the oven without heat

**Table 4.1**

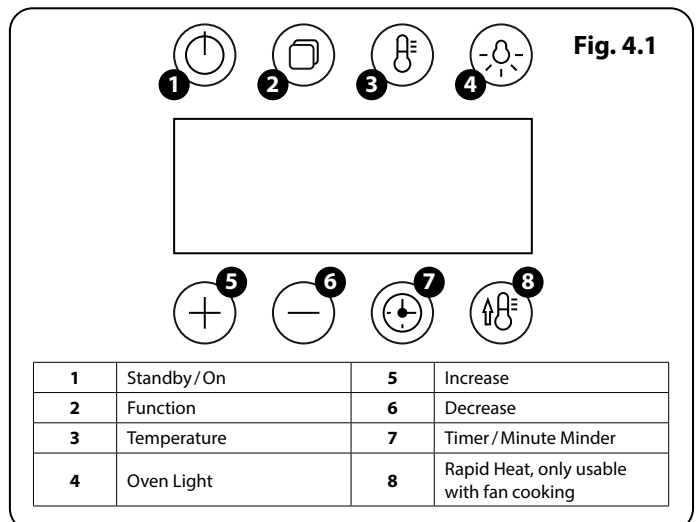
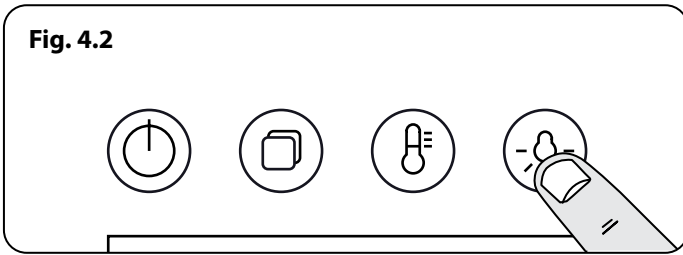

Fig. 4.2



## ECO Mode

This setting saves energy, cooking in fanned mode, for foods requiring a cooking time of 45 minutes or less. No preheating .

**Note:** The oven door must remain closed during ECO mode. Failure to do so will result in the oven continuing to cook after the pre-set 45 minutes.

The following foods are recommended for the ECO setting:

- Ready prepared meals - meals should have the maximum duration of 45 minutes from chilled, and must not be frozen.
- Cookies, brownies and similar non-yeast baked food.

We always recommend that any food is checked to ensure it is fully cooked through. If in doubt please allow extra time.

## Rapid Heat

The "Rapid Heat" setting (**8**) enables you to preheat the oven faster than normal. It uses the fan oven element with additional heat from one of the elements in the top of the oven.

When the oven cavity has reached the set temperature an alarm will sound, the rapid heat cycle will end and the selected cook mode will be activated.

**Rapid heat mode can only be activated when the Fan function is selected.**

## Oven Lights

Tap the button to turn the oven light on (**Fig. 4.2**).

If the oven light fails, turn off the power supply before changing the bulb. See the *'Troubleshooting'* section for details on how to change the bulb.

## Display Lock

To lock the display touch and hold the [+] and [-] buttons simultaneously. This will prevent the buttons being used. The lock symbol [] will be displayed.

To unlock the display touch and hold the [+] and [-] buttons again. The lock symbol will go out.

## Accessories

### Glide-out Oven Shelves

The left-hand oven is supplied with 2 glide-out oven shelves.

To fit the glide-out shelf, hook the front of the shelf onto the runners as shown (Fig. 4.3). The rear of the shelf should rest on the runners, in front of the rear stop (Fig. 4.3).

The glide-out shelf and runners can be easily removed or repositioned.

#### To remove the glide-out shelf

Raise the rear of the shelf, so that it clears the rear stops. Then unhook from the front locating bracket.

#### To remove the glide-out runners

Twist to unclip the base of the runners from the shelf supports. Then unhook the runner from the top rung of the shelf support and remove (Fig. 4.4).

#### To refit the glide-out runners

Hook the rear of the runner over the top rung of a pair of shelf supports. Then hook the front of the runner onto the same rung. Push to clip under the bottom rung (Fig. 4.5).

Ensure that the shelf runners are fitted in the same position on each side (Fig. 4.6).

The front of the shelf runners can be identified by the bracket (Fig. 4.3).

**⚠ DO NOT put the glide-out shelf runners in a dishwasher.**

### Steam cavity Shelves

The steam cavity shelves (Fig. 4.7) are retained when pulled forward but can be easily removed and refitted.

Pull the shelf forward until the back of the shelf is stopped by the shelf stop bumps in the oven sides (Fig. 4.8).

Lift up the front of the shelf so the back of the shelf will pass under the shelf stop and then pull the shelf forward (Fig. 4.9).

To refit the shelf, line up the shelf with a groove in the oven ladders and push the shelf back until the ends hit the shelf stop. Lift up the front so the shelf ends clear the shelf stops, and then lower the front so that the shelf is level and push it fully back (Fig. 4.10).

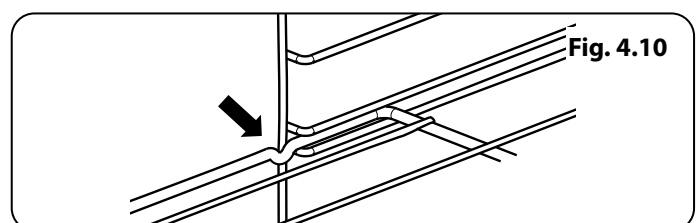
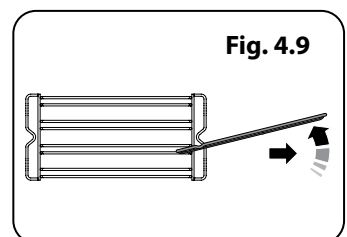
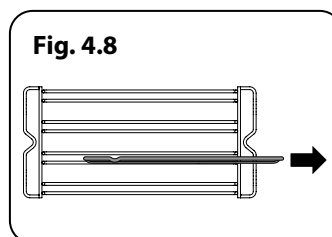
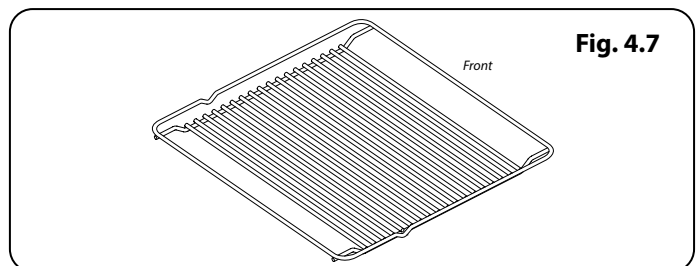
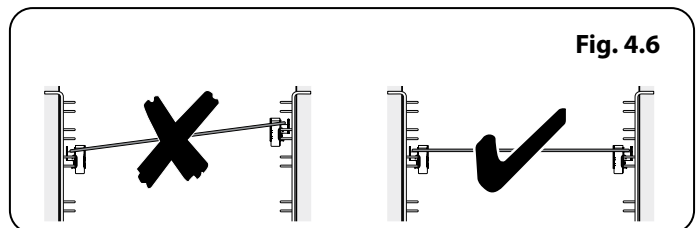
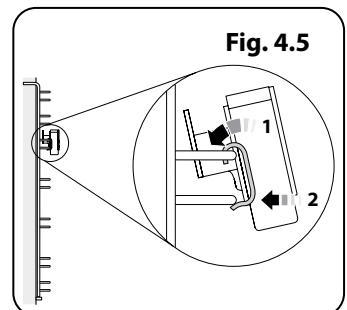
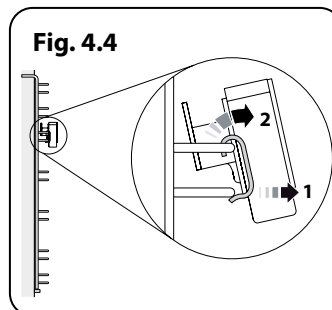
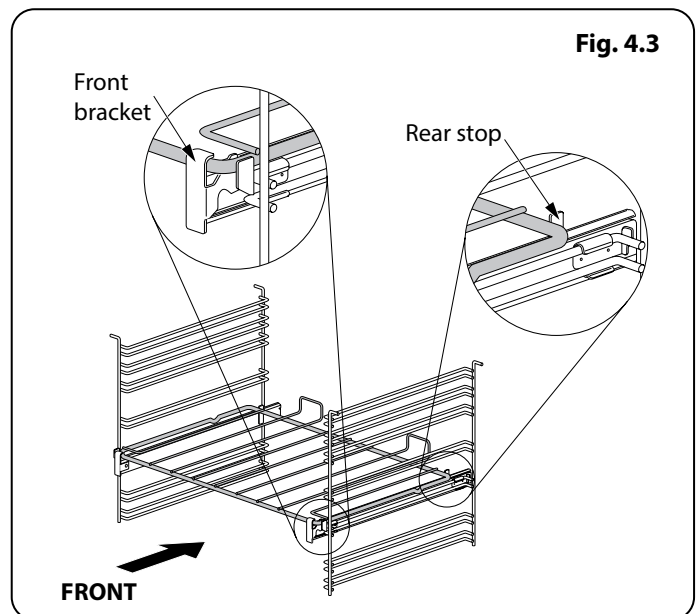

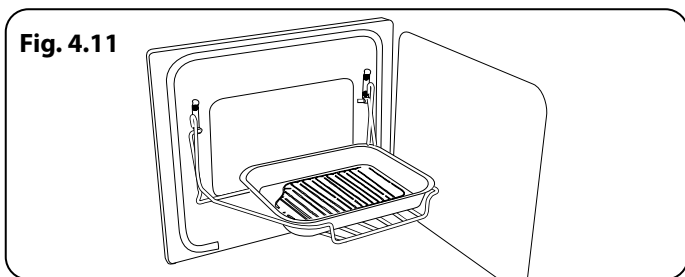

Fig. 4.11

## The Handyrack *(Optional extra)*

The Handyrack (**Fig. 4.11**) fits to the left-hand oven door only. Food cooking on it is easy to attend to, because it is accessible when the door is open.

The maximum weight that can be held by the Handyrack is 5.5 kg (12 lb). It should only be used with the supplied roasting tin, which is designed to fit the Handyrack. Any other vessel could be unstable.

It can be fitted at two different heights. One of the oven shelves must be removed and the other positioned to suit.

When the Handyrack is used in its highest position, other dishes can be cooked on the bottom shelf position or base of the oven.

When the Handyrack is used in its lowest position, other dishes can be cooked on the second shelf position or base of the oven.

To fit the Handyrack, locate one side of it on the door bracket (**Fig. 4.12**).

Then spring the other side out to clip it onto the other bracket (**Fig. 4.13**).

## The Clock / Timer

**The clock must be set to the time of day before the multi-function oven or steam cavity will work.**

### Setting the clock

1. Once the cooker is connected and switched on, the hours in the display will flash (**Fig. 4.14**).
2. Whilst the hours are flashing tap either the [+] or [-] buttons to set the hour.
3. Tap the 'timer' button and the minutes will flash. Use the [+] or [-] buttons to set the minutes (**Fig. 4.15**).

To re-set the time, touch and hold the 'timer' button until the hours begin to flash then repeat the procedure described above using the [+] or [-] buttons.

**Note:** If no button is tapped, the current time will be saved by the clock, after 5 seconds.

### Setting the minute minder

The minute minder can be set as a reminder when the main oven is on or off.

The minute minder provides the ability to set a countdown from 00:01h to 23:59h, at the end of which an alarm will sound. The timer shows *hours:minutes*.

1. Tap the timer button once to enter the minute minder (**Fig. 4.16**).
2. The hours will start to flash. Set the hours using the [+] or [-] buttons (**Fig. 4.16**).
3. Tap the timer button again, the minutes will flash. Set the minutes using the [+] or [-] buttons. The countdown will automatically begin after 3 seconds and the [⏰] symbol will show in the display.

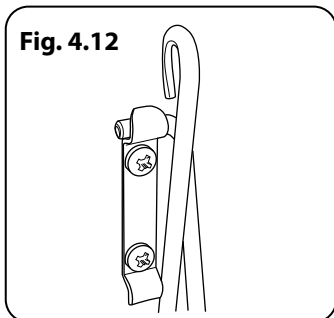

Fig. 4.12

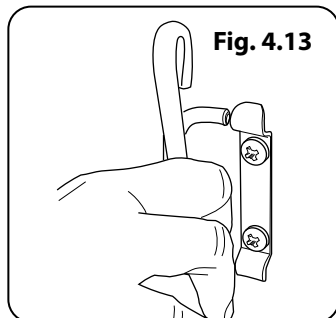

Fig. 4.13

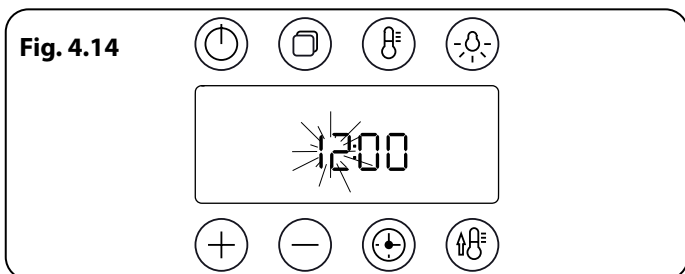

Fig. 4.14

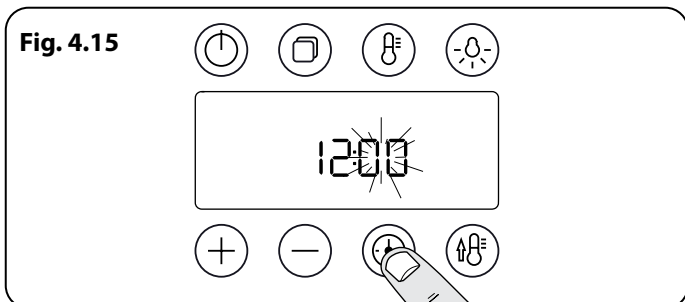

Fig. 4.15

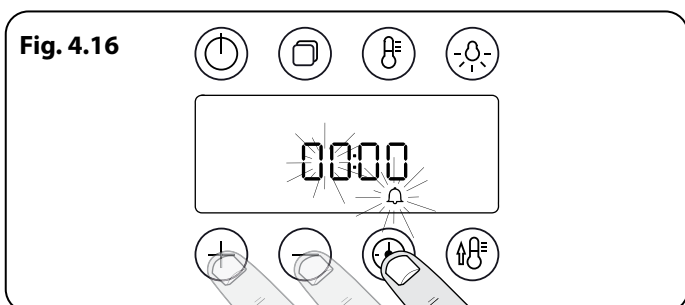

Fig. 4.16

- Once the specified time has elapsed an alarm will sound. It will stop automatically after 10 seconds.
- To cancel the minute minder, and enter a new time, tap the clock button whilst the [⌚] symbol is active.

#### To stop the multifunction oven after a specific time

- Set the cooking function and temperature (see "Operating the Multifunction Oven" on page 15).
- Touch and hold the 'timer' button until the cook period symbol [⌚] is displayed (Fig. 4.17). Set the hours using the [+] or [-] buttons.
- Tap the timer button again to set the minutes using the [+] or [-] buttons. Cooking will automatically start after 5 seconds and the remaining cook period will be displayed.
- At the end of the cooking period an alarm will sound and the oven will stop cooking. 'End' will show in the display. Remove the cooked food from the oven and close the oven door.
- If the alarm is not stopped it will repeat twice before stopping automatically.

#### To start and then stop the multifunction oven

Set the multifunction oven to automatically start and stop using a combination of the 'cook period' and 'stop time'.

You cannot set a start time directly – this is set automatically by a combination of the 'cook period' and 'stop time'.

- Set the cooking function and temperature (see "Operating the Multifunction Oven" on page 15).
- Touch and hold the 'timer' button until the cook period symbol [⌚] is displayed. Set the hours using the [+] or [-] buttons. Tap the timer button again to set the minutes using the [+] or [-] buttons (Fig. 4.17).
- Tap the 'timer' button to select the 'stop time' [→]. Set the the time you would like to stop cooking using the [+] or [-] buttons. Tap the 'timer' button again to set the minutes using the [+] or [-] buttons.
- The oven will enter Standby Mode after 3 seconds, the display will show the 'cook period' (Fig. 4.18) and the 'stop time' (Fig. 4.19). Changing the cooking function will clear the selection.
- When the 'stop time' is reached an alarm will sound and the oven will stop cooking. 'End' will show in the display. Remove the cooked food from the oven and close the oven door.
- If the alarm is not stopped it will repeat twice before stopping automatically.

**Note:** Fig. 4.18 and Fig. 4.19 show conventional heat function for illustration. All other modes are available.

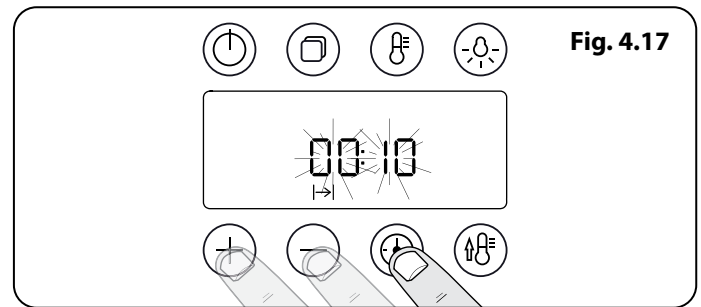

Fig. 4.17

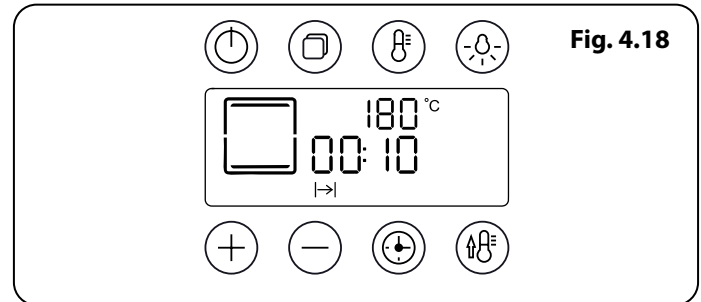

Fig. 4.18

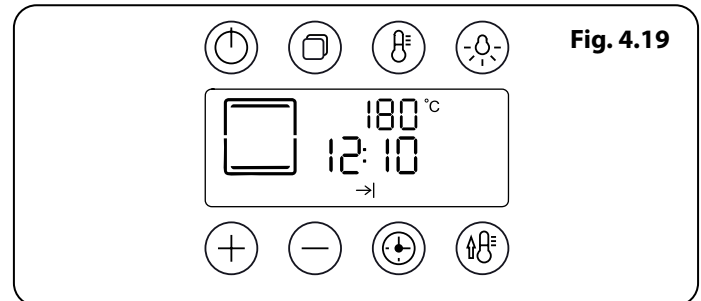





Fig. 4.19

## Cooking Tips

### Tips on cooking with the timer

If you want to cook more than one dish, choose dishes that require approximately the same cooking time. However, dishes can be 'slowed down' slightly by using small containers and covering them with aluminium foil, or 'speeded up' slightly by cooking smaller quantities or placing them in larger containers.

Very perishable foods such as pork or fish should be avoided if a long delay period is planned, especially in hot weather.

-  **DO NOT place warm food in the oven to be timed.**
-  **DO NOT use a timed oven that is already warm.**
-  **DO NOT use the timed oven if the adjoining oven is already warm.**

Whole poultry must be thoroughly defrosted before being placed in the oven. Check that meat and poultry are fully cooked before serving.

### General oven tips

The wire shelves should always be pushed firmly to the back of the oven.

Baking trays with food cooking on them should be placed level with the front edge of the oven's wire shelves. Other containers should be placed centrally. Keep all trays and containers away from the back of the oven, as overbrowning of the food may occur.

For even browning, the maximum recommended size of a baking tray are:

- depth: 340 mm (13 3/8") by width: 340 mm (13 3/8") in the main oven

**When the oven is on, DO NOT leave the door open for longer than necessary, otherwise the knobs may get very hot.**

- Always leave a "finger's width" between dishes on the same shelf. This allows the heat to circulate freely around them.
- To reduce fat splashing when you add vegetables to hot fat around a roast, dry them thoroughly or brush lightly with cooking oil.
- Where dishes may boil and spill over during cooking, place them on a baking tray.
- The 'Cook & Clean' oven liners (see 'Cleaning Your Cooker') work better when fat splashes are avoided. Cover meat when cooking.
- Sufficient heat rises out of the oven while cooking to warm plates in the grill compartment.
- If you want to brown the base of a pastry dish, preheat the baking tray for 15 minutes before placing the dish in the centre of the tray.



# Cooking Table

The oven control settings and cooking times given in the table below are intended to be used **as a guide only**. Individual tastes may require the temperature to be altered to provide a preferred result.

Food is cooked at lower temperature in a fan oven than in a conventional oven. When using recipes, reduce the fan oven temperature by 10°C and the cooking time by 5-10 minutes. The temperature in the fan oven does not vary with height in the oven so you can use any shelf.

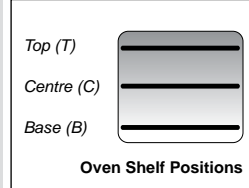

Food	Conventional Oven °C (Shelf Position)	Fan Oven Temperature	Approximate Cooking Time	
<b>Meat</b>				
Beef (no bone)	160 (C)	150 °C	30-35 minutes per 500g +30-35 minutes.	Thoroughly thaw frozen joints before cooking. Meat may be roasted at 220°C (210°C for fan oven) and the cooking time adjusted accordingly. For stuffed and rolled meats, add approximately 10 minutes per 500g, or cook at 200°C (190°C) for 20 minutes then 160°C (150°C) for the remainder.
	200 (C)	190 °C	20-25 minutes per 500g +20-25 minutes.	
Lamb	160 (C)	150 °C	30-35 minutes per 500g +30-35 minutes.	
	200 (C)	190 °C	25-30 minutes per 500g +25-30 minutes.	
Pork	160 (C)	150 °C	35-40 minutes per 500g +35-40 minutes.	
	200 (C)	190 °C	25-30 minutes per 500g +25-30 minutes.	
<b>Poultry</b>				
Chicken	160 (C)	150 °C	20-25 minutes per 500g +20-25 minutes.	For stuffed poultry, you could cook at 200°C (190°C) for 20 minutes then 160°C (150°C) for remainder. Do not forget to include the weight of the stuffing.
	200 (C)	190 °C	15-20 minutes per 500g +15-20 minutes.	
Turkey	160 (C)	150 °C	20 minutes per 500g +20 minutes.	
	200 (C)	190 °C	15 minutes per 500g +15 minutes.	
Duck	160 (C)	150 °C	25-30 minutes per 500g.	For fresh or frozen prepacked poultry, follow instructions on the pack. Thoroughly thaw frozen poultry before cooking.
	200 (C)	190 °C	20 minutes per 500g.	
Casserole	140-150 (C)	130 °C-140 °C	2-4 hours according to recipe.	
<b>Yorkshire Pudding</b>	220 (C)	210 °C	Large tins 30-35 minutes; individual 10-20 minutes.	
<b>Cake</b>				
Very rich fruit - Christmas, wedding, etc.	140 (C/B)	130 °C	45-50 minutes per 500g of mixture.	Using the conventional oven: when two tier cooking leave at least one runner space between shelves.
Fruit 180 mm tin	150 (C/B)	140 °C	2-2½ hours.	
Fruit 230 mm tin	150 (C/B)	140 °C	Up to 3½ hours.	
Madeira 180 mm	160 (C/B)	150 °C	80-90 minutes.	Position the baking tray with the front edge along the front of the oven shelf.
Queen cakes	190 (C/B)	180 °C	15-25 minutes.	
Scones	220 (C/B)	210 °C	10-15 minutes.	Up to three tiers can be cooked in a fan oven at the same time but make sure to leave at least one runner space between each shelf being cooked on.
Victoria sandwich				
180 mm tin	180 (C/B)	170 °C	20-30 minutes.	
210 mm tin	180 (C/B)	170 °C	30-40 minutes.	
<b>Desserts</b>				
Shortcrust tarts	200 (C/B)	190 °C	20-30 minutes on a preheated tray.	Up to three tiers can be cooked in a fan oven at the same time but make sure to leave at least one runner space between each shelf being cooked on.
Fruit pies	200 (C/B)	190 °C	35-45 minutes.	
Tartlets	200 (C/B)	190 °C	10-20 minutes according to size.	
Puff pastry	210 (C/B)	200 °C	20-40 minutes according to size.	
Meringues	100 (C/B)	90 °C	2-3 hours.	
Baked egg custard	160 (C/B)	150 °C	45-60 minutes.	
Baked sponge pudding	180 (C/B)	170 °C	40-45 minutes.	
Milk pudding	140-150 (C/B)	130 °C-140 °C	2 to 3 hours.	
<b>Bread</b>	210 (C)	200 °C	20-30 minutes.	
<b>Fish</b>				
	Fanned Grilling			
Fillet	190 (C/B)	190 °C (C/B)	15-20 minutes	
Whole	190 (C/B)	190 °C (C/B)	15-20 minutes per 500g.	
Steak	190 (C/B)	190 °C (C/B)	Steaks according to thickness.	

## 5. The Steam Cavity

Fig. 5.1

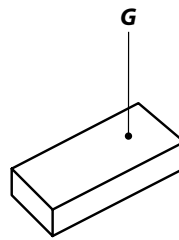
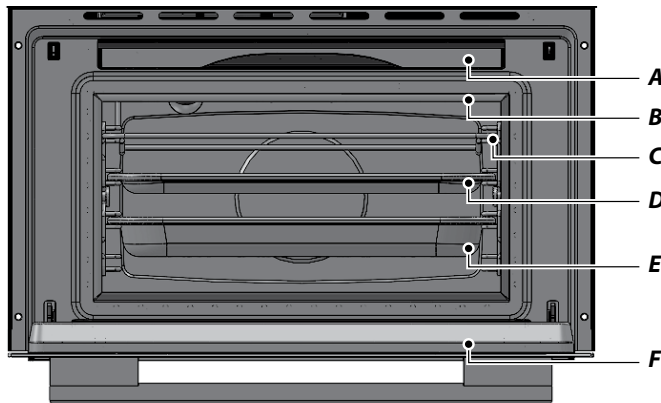

Key	
A	Water Tank
B	Door Seal
C	1 x Rack
D	1 x Pan
E	1 x Perforated Pan
F	Door
G	Sponge

Fig. 5.2

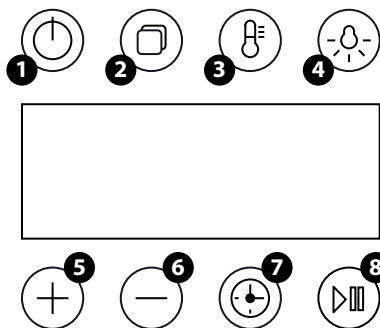

1	Standby / On	5	Increase
2	Function	6	Decrease
3	Temperature	7	Timer
4	Oven Light	8	Start / Pause

Fig. 5.3

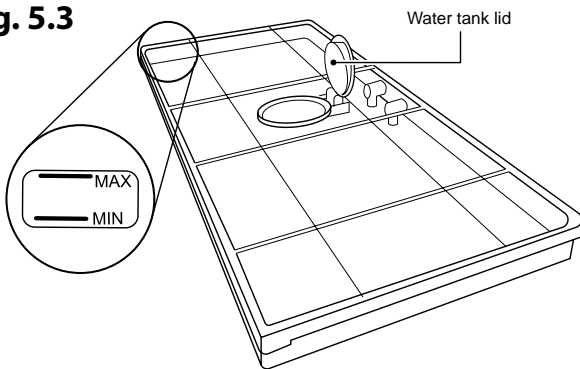

### The Steam Cavity (right-hand)

The steam cavity is shown in Fig. 5.1.

Fig. 5.2 shows the touch sensitive control panel for the steam cavity.

### Water Level

To fill the water tank or check the water level lift and pull the water tank from the oven cavity (Fig. 5.1).

Lift the lid and carefully fill from the tap or a small jug up to the maximum marker (Fig. 5.3). Wipe clean if the water overflows.

The clock, on the left hand oven, must be set to the time of day before the oven will work. See the section on 'The Clock / Timer' for instructions on setting the time of day.

**References to 'left-hand' and 'right-hand' ovens apply as viewed from the front of the appliance.**

The left-hand oven is a multifunction oven, while the right-hand oven is a steam cavity.

**Note:** The time of day is not displayed on the steam cavity control.

### Display Lock

To lock the display touch and hold the [+] and [-] buttons simultaneously. This will prevent the buttons being used. The lock symbol  will be displayed.

To unlock the display touch and hold the [+] and [-] buttons again.

### Hygiene

**Please remember to:**

- Change the water in the tank before use. The display will remind you (Fig. 5.9).
- Clean the steam cavity after every cook cycle.

** The base of the steam cavity will remain HOT after use. Take extra care when cleaning.**

- Observe the descaling interval.

## Operating the Steam Cavity

**Note:** The steam cavity may start a pump out cycle (**Fig. 5.12**) when first turned on. This is normal and it should be allowed to complete. The cycle will take approximately 2 minutes.

1. Touch and hold the standby button to switch the steam cavity on (**Fig. 5.4**). The display will show the maximum temperature; 100°C, a 15 minute cook time and the steam icon will flash (**Fig. 5.5**).
2. To adjust the temperature, touch and hold the temperature button (**Fig. 5.6**) and use the [+] or [-] buttons to adjust (**Fig. 5.7**).
3. To adjust the cook period, tap the timer button once, to adjust the hours use the [+] or [-] buttons (**Fig. 5.8**). Tap the timer button again to adjust the minutes.
4. Tap the start/pause button. You will be advised to change the water in the tank (**Fig. 5.9**). See 'Water Level' on page 22. If you are already using fresh water touch start or wait to continue.

The appliance will begin to pump water, from the water tank, into the boiler (**Fig. 5.10**).

5. The oven cavity will begin to heat up to your set temperature. You can check the current temperature in the oven cavity by tapping the temperature button (**Fig. 5.6**).

When the oven has reached the pre-set temperature, the cook cycle will begin and the decimal points in the timer will flash.

Once cooking has completed, [END] will be displayed and 10 beeps will be emitted. This will be repeated twice. Also, the cavity light will turn on and the cooker fan will run for 2 minutes.

6. At the end of the cooking cycle the display will show *H2O HOT* (**Fig. 5.11**), this indicates the water in the boiler is hot and will be pumped back into the water tank once it has reached a pre-set temperature. When the water is being pumped out *H2O OUT* (**Fig. 5.12**) will be displayed.

Please allow the cycle to complete.

7. You can immediately re-use your steam cavity by tapping the [+] or [-] buttons.
8. The cooking cycle can be suspended at any time by tapping the pause button.

**Note:** It is normal for steam to be emitted from the steam cavity. This is not harmful.

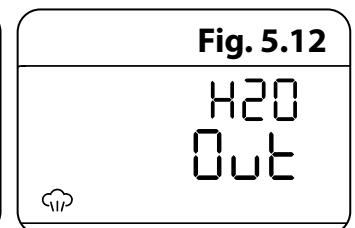
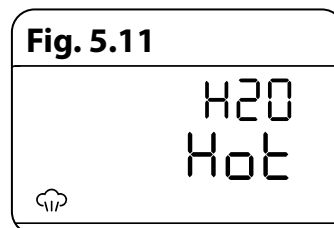
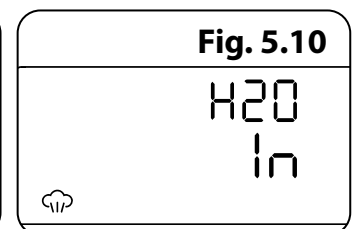
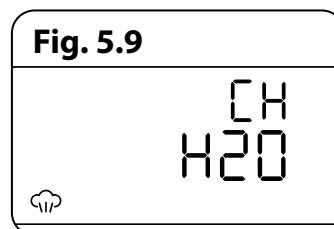
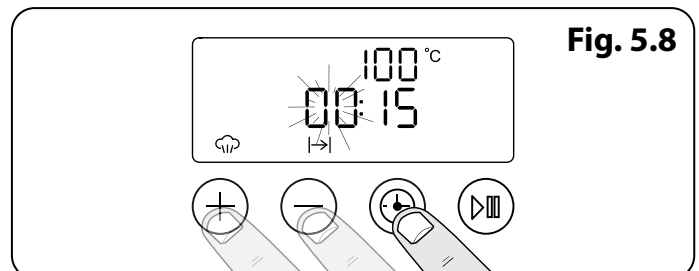
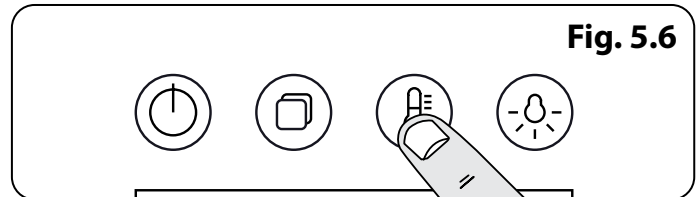
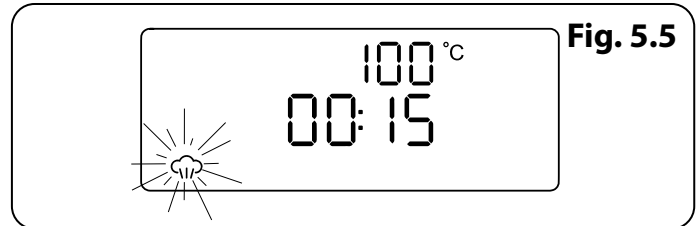
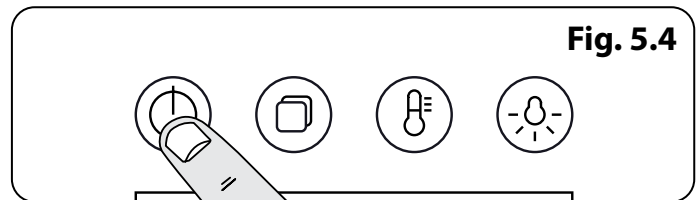

**Fig. 5.13**

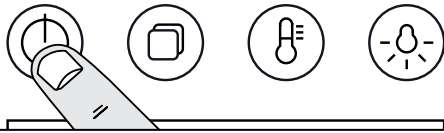

**Fig. 5.14**

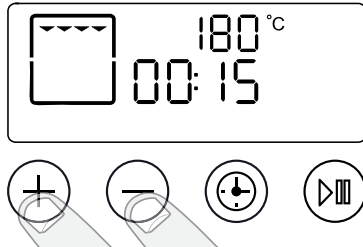

**Fig. 5.15**

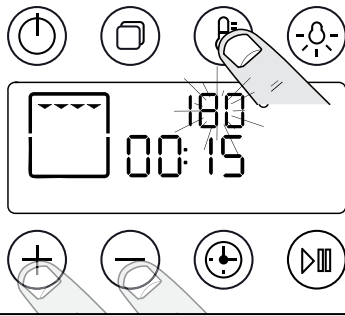

**Fig. 5.16**

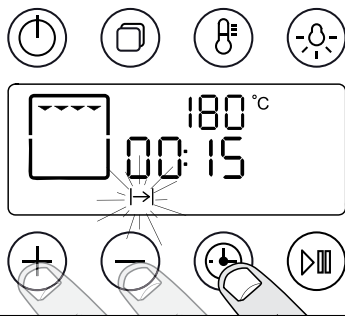

**Fig. 5.17**

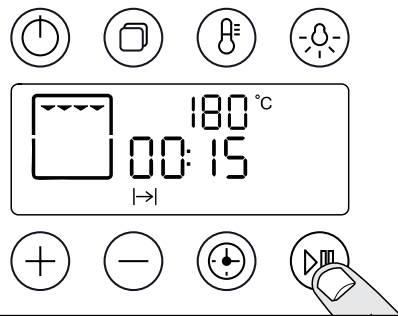

## Steam Cavity Functions

The steam cavity has three main functions:

steam 

grill 

descale 

Switch the oven on and tap the [+] or [-] buttons to scroll through these functions.

## Using the Grill Function in the Steam Oven Cavity

1. Touch and hold the standby button to switch the steam cavity on (**Fig. 5.13**) then use the [+] or [-] buttons to scroll through to the grill function (**Fig. 5.14**).
2. The default temperature is 180°C. To adjust the temperature, touch the temperature button then use the [+] or [-] buttons to adjust (**Fig. 5.15**). An audible beep will sound when the grill is up to temperature. The maximum temperature is 200°C and the minimum temperature is 40°C.
3. To adjust the cook period, tap the timer button once, to adjust the hours use the [+] or [-] buttons (**Fig. 5.16**). Tap the timer button again to adjust the minutes. The cook duration symbol [I->] will flash during this procedure.
4. A beeping sound will be heard once the grill has reached the set temperature.
5. To begin grilling tap the start /pause button (**Fig. 5.17**).

## Program Modes

The steam cavity has pre-programmed modes for different food types.

To access these modes touch and hold the standby button to switch the steam cavity on.

Touch and hold the program button (**Fig. 5.13**). [A1] will show in the display. Scroll through the programs using the [+] or [-] buttons.

Touch and hold the program button again to access the next set of programs for fish. [b1] will be displayed.

Touch and hold the program button a third time to access the programs for meat. [C1] will be displayed.

See **Table 5.1** for an overview of the program functions.

<b>Vegetables</b>					
<b>Program</b>	<b>Type of vegetables</b>	<b>Temperature (°C)</b>	<b>Time (min)</b>	<b>Container</b>	<b>Level</b>
A1	Medium broccoli florets	100	8	Perforated	2
A2	Carrot batons	100	8	Perforated	2
A3	New potatoes	100	18	Perforated	2
A4	Green beans	100	6	Perforated	2
A5	Asparagus	100	4	Perforated	2

<b>Fish</b>					
<b>Program</b>	<b>Type of fish</b>	<b>Temperature (°C)</b>	<b>Time (min)</b>	<b>Container</b>	<b>Level</b>
b1	120g salmon fillet	90	4	Perforated	2
b2	Raw tiger prawns	90	5	Perforated	2
b3	Kippers	100	6	Perforated	2
b4	Cod/Haddock Fillets	100	8	Perforated	2
b5	Mussels	90	8	Perforated	1/2

<b>Meat</b>					
<b>Program</b>	<b>Type of meat</b>	<b>Temperature (°C)</b>	<b>Time (min)</b>	<b>Container</b>	<b>Level</b>
C1	Meatballs	100	8	Solid	2
C2	Turkey Escalope and chicken breasts	100	10	Solid	2
C3	Bratwurst / hot dogs	100	10	Perforated	2
C4	Large soft boiled egg(s) (at room temperature)	100	6	Perforated	2
C5	Large hard-boiled egg(s) (at room temperature)	100	10	Perforated	2

Items to be cooked should be spread evenly on the cooking trays.

**Table 5.1**

**Fig. 5.18****Fig. 5.19****Fig. 5.20**

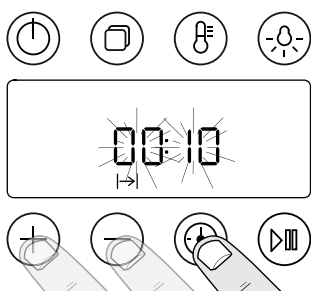
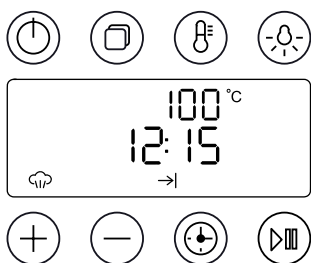
## The Clock / Timer

The clock above the multi-function oven must be set to the time of day before the multi-function oven or steam cavity will work.

See "Setting the clock" on page 18.

**Note:** The steam cavity control does not show the time of day. This is automatically set from the multi-function oven control.

The display will remain blank until the steam cavity is turned on.

### To stop the steam cavity at a specific time of day

1. Switch the cavity on and set the temperature (see 'Operating the Steam Cavity' on page 23).
2. Tap the timer button to set the 'cook period' hours using the [+] or [-] buttons. Tap the timer button again to set the minutes using the [+] or [-] buttons (**Fig. 5.18**).
3. Tap the Start/Pause button.

### To start and then stop the steam cavity

Set the steam cavity to automatically start and stop using a combination of the 'cook period' and 'stop time'.

You cannot set a start time directly – this is set automatically by a combination of the 'cook period' and 'stop time'.

1. Switch the oven on and set the temperature (see 'Operating the Steam Cavity' on page 23).
2. Tap the 'timer' button, the cook period symbol [▶] is displayed. Set the hours using the [+] or [-] buttons. Tap the timer button again to set the minutes using the [+] or [-] buttons.
3. Tap the 'timer' button to select the 'stop time' [→]. Set the time you would like to stop cooking using the [+] or [-] buttons. Tap the 'timer' button again to set the minutes using the [+] or [-] buttons.
4. Tap the Start/Pause button. The display will show the 'cook period' (**Fig. 5.19**) and the 'stop time' (**Fig. 5.20**).
5. When the 'stop time' is reached an alarm will sound and the oven will stop cooking. 'End' will show in the display.

Tap the 'temperature' button during the cooking cycle to display the current oven temperature.

## 6. Cleaning Your Cooker

### Essential Information

Isolate the electricity supply before carrying out any thorough cleaning. Allow the cooker to cool.

**⚠ Never use paint solvents, washing soda, caustic cleaners, biological powders, bleach, chlorine based bleach cleaners, coarse abrasives or salt.**

**⚠ Do not mix different cleaning products – they may react together with hazardous results.**

All parts of the cooker can be cleaned with hot soapy water – **but take care that no surplus water seeps into the appliance.**

Remember to switch on the electricity supply and reset the clock before re-using the cooker.

### Hotplate Burners

The burner heads and caps can be removed for cleaning.

**⚠ DO NOT put the burner heads in a dishwasher.**

Make sure they are absolutely dry before replacing them.

### The Single Ring Burners

When refitting the burner head, make sure that the notch lines up with the electrode or hole in the base. Check that the burner head is level and that the cap is fitted centrally on the burner head (**Fig. 6.1**).

### The Wok Burner

The wok burner can also be taken apart for cleaning.

When reassembling the wok burner (**Fig. 6.2**), turn over the large base ring and find the 'D' shaped area (**Fig. 6.3**). Turn the head until the 'D' matches the one on the burner base. Flip the burner over once again and place it on the burner base.

Check the burner slots are not blocked. If a blockage occurs, remove stubborn particles using a toothbrush (**Fig. 6.4**).

Now fit the two burner caps, making sure that they are seated properly.

Check the burner ports are not blocked. If a blockage occurs, remove stubborn particles using a piece of fuse wire.

### The Wok Cradle

Recommended cleaning materials are hot soapy water, a moistened soap pad, cream cleaner or a nylon scourer.

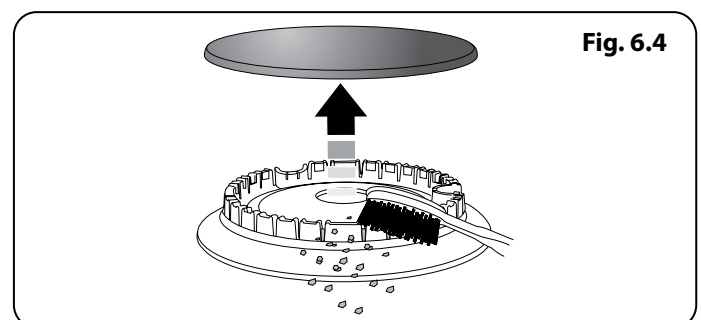
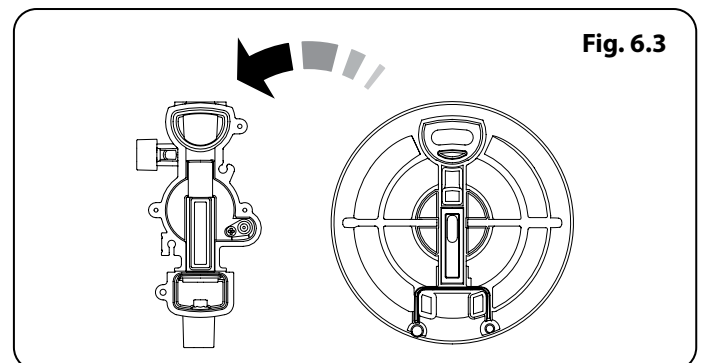
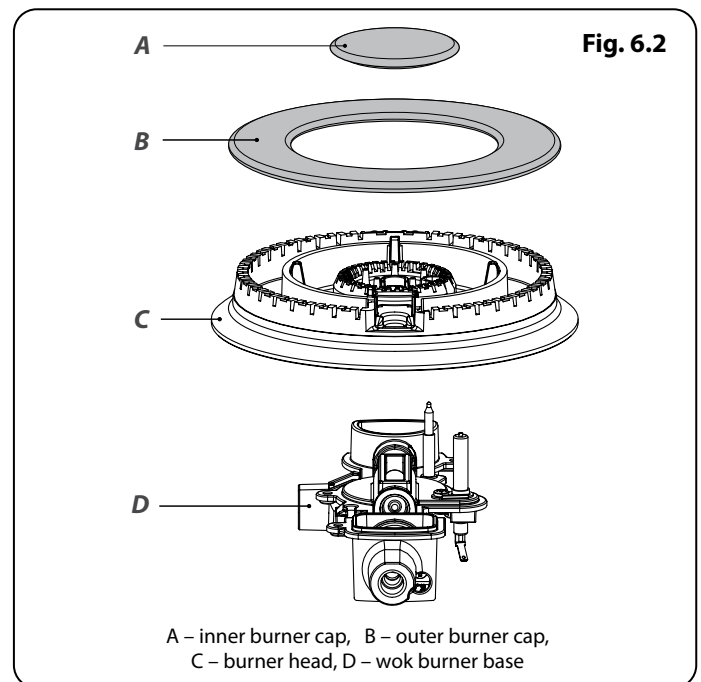
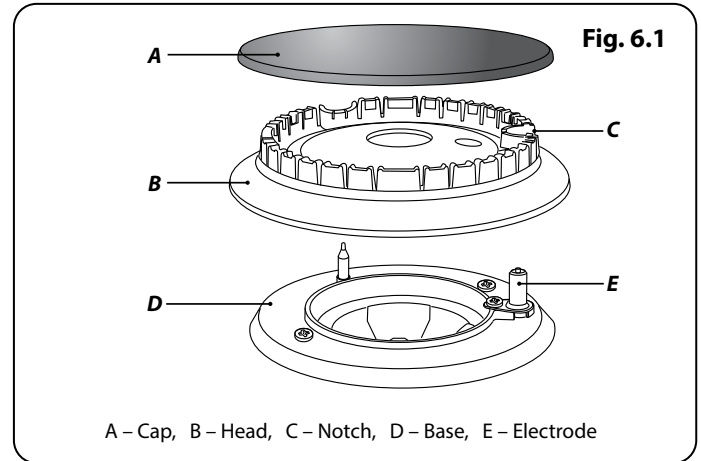
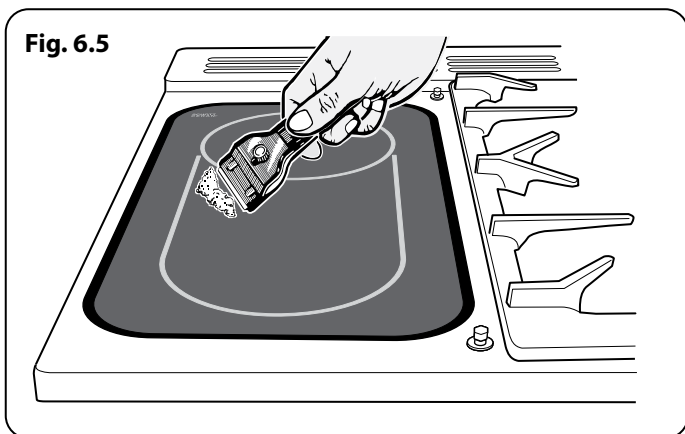

Fig. 6.5



## Ceramic Hotplate

### Daily Care

First of all, make sure that the heat indicator light is off and that the cooking surface is cool.

Apply a small dab of ceramic cleaning cream in the centre of the area to be cleaned. Dampen a clean paper towel and work the cream onto the cooking surface. As a final step, wipe the cooking surface with a clean, dry paper towel.

### Cleaning Spills

For spills and boil-overs that occur while cooking, turn off the unit and wipe the area surrounding the hot zone with a clean paper towel. If a spill (other than a sugary substance) is on the hot zone, do not clean until the unit has completely cooled down, and then follow the instructions below, 'Cleaning Burned-on Spills'.

If you accidentally melt anything on the surface or if you spill foods with a high sugar content (preserves, tomato sauce, fruit juice, etc.), remove the spill IMMEDIATELY with a razor scraper, while the unit is still hot.

**IMPORTANT: Use an oven glove to protect your hand from potential burns.**

Scrape the major spill or melted material from the cooking zone and push into a cold area. Then, turn the unit 'OFF' and allow to cool before cleaning further. After the cooking surface cools down and the heat indicator lights go off, follow the 'Daily Care' procedure outlined above.

### Cleaning Burned-on Spills

Make sure that the heat indicator lights are off and that the hob is cool. Remove the excess burned-on substance with a single-edged razor scraper. Hold the scraper at an angle of about 30° to the surface and then scrape off the burned-on matter (**Fig. 6.5**).

Once you have removed as much as possible with the scraper, follow the 'Daily Care' procedure outlined above.

### To Remove Metal Rub-off

Sliding pans on the hob – especially aluminium or copper pans – can leave marks on the ceramic surface. These marks often appear like scratches, but can easily be removed (see 'Cleaning Spills'). If the rub-off marks are especially stubborn, use a cleaning cream together with the razor.

## The Griddle Plate

Always clean the griddle plate after use. Allow it to cool completely before removing. Immerse the griddle plate in hot soapy water. Use a soft cloth or, for stubborn stains, a nylon washing up brush.

**Note:** If the griddle plate is washed in a dishwasher then some dishwasher residue may appear on the back. This is normal and will not affect the performance of your griddle plate.



## Grills

The grill pan and trivet should be washed in hot soapy water. Alternatively, the grill pan can be washed in a dishwasher.

After grilling meats or any foods that soil, leave to soak for a few minutes immediately after use. Stubborn particles may be removed from the trivet using a nylon brush.

**⚠ Before you remove any of the grill parts for cleaning, make sure that they are cool, or use oven gloves.**

**⚠ DO NOT use any abrasive substances.**

### Cleaning the Glide-out Grill

The grill pan can be easily removed for cleaning as follows. Remove the grill pan support frame by pulling the grill pan forward (**Fig. 6.6**).

Lift the grill pan clear of the support frame. The support frame is held to the side rails by two clips on each side (**Fig. 6.7**).

For each side, support the side rail with one hand and with the other hand lift the frame up and out of the side clips (**Fig. 6.8**).

For safety, push the side rails back into the grill chamber.

If you need to remove the side rails to allow cleaning of the grill chamber, you can unhook them from the grill chamber sides (**Fig. 6.9**) and wipe the sides clean with a soft cloth and mild detergent.

**⚠ DO NOT put the side runners in a dishwasher.**

Once you have finished, hook the side rails back onto the sides of the chamber. To refit the frame, pull the side rails forward and, for each side in turn, support the side rail and press the frame down into the side rails.

### Control Panel and Doors

Avoid using any abrasive cleaners, including cream cleaners. For best results, use a liquid detergent.

The same cleaner can also be used on the doors. Alternatively, use a soft cloth wrung out in clean hot soapy water. You can use the same method for cleaning the control panel and knobs. After cleaning, polish with a dry cloth.

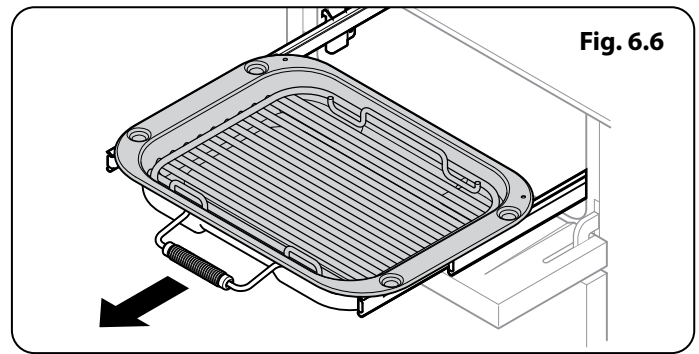

Fig. 6.6

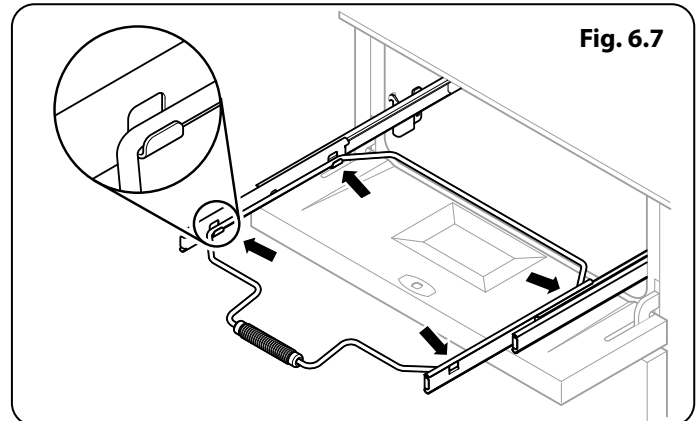

Fig. 6.7

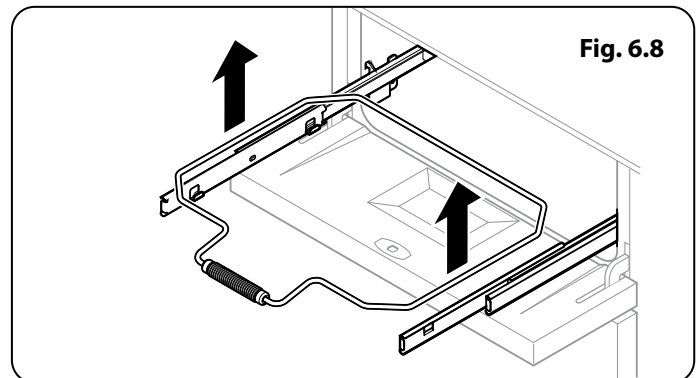

Fig. 6.8

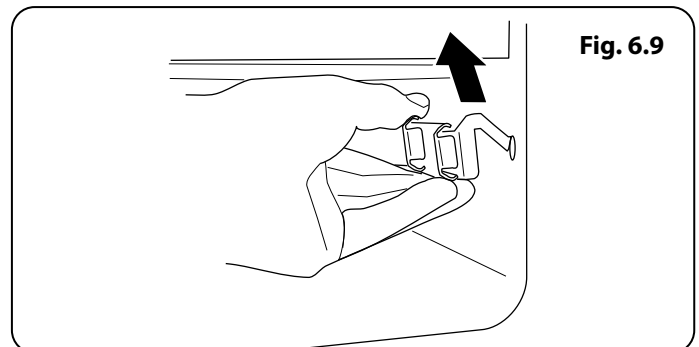
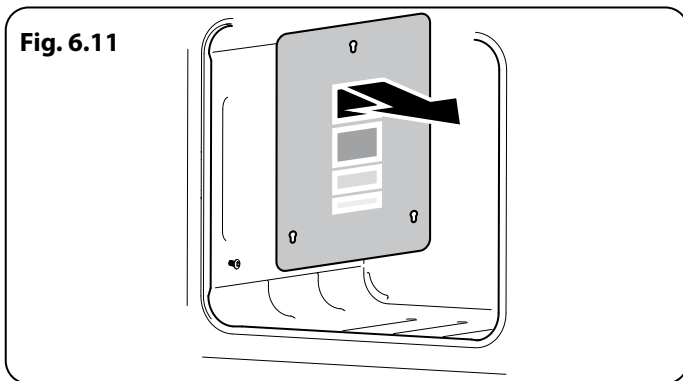
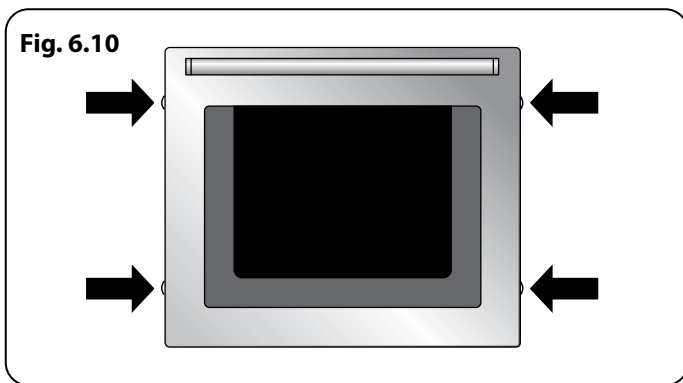

Fig. 6.9



## Glass Fronted Door Panels

The oven door front panels can be taken off so that the glass panels can be cleaned. Move the cooker forward to gain access to the sides (see the 'Moving the Cooker' section under 'Installation').

Open the oven door slightly and remove the front panel fixing screws from the door sides, two each side (**Fig. 6.10**).

Carefully lift off the outer door panel. The inside face of the glass panels can now be cleaned – take care not to disturb or wet the door insulation.

**Note:** If the door is triple glazed then the inner two panels are fixed together and should not be separated. After cleaning, carefully refit the outer door panel and replace the side fixing screws.

**⚠ DO NOT use harsh abrasive cleaners or sharp metal scrapers to clean the oven door glass since they can scratch the surface, which may result in shattering of the glass.**

## Multifunction Oven

### 'Cook & Clean' Panels

The ovens have side 'Cook & Clean' panels which have been coated with a special enamel that partly cleans itself. This does not stop all marks on the lining, but helps to reduce the amount of manual cleaning needed.

These panels work better above 200°C. If you do most of your cooking below this temperature, occasionally remove the panels and wipe with a lint free cloth and hot soapy water. The panels should then be dried and replaced and the oven heated at 200°C for about one hour. This will make sure that the panels are working effectively.

### Removing the Panels to Clean the Enamel Interior

Some of the lining panels can be removed for cleaning.

If you wish to clean the enamel interior of the oven, you will need to remove the shelves before removing the 'Cook & Clean' panels. To remove the side panels, simply lift the panel and slide forwards (**Fig. 6.11**).

Once the panels have been removed, the oven enamel interior can be cleaned.

**⚠ DO NOT use steel wool, oven cleaning pads, or any other materials that will scratch the surface.**

Refit in the reverse order.

## Steam Cavity

- ⚠ Before cleaning your oven or performing maintenance, please switch off the power supply. In order to prolong the service life of steam cavity, please note the following points:**

The enameled or stainless steel parts should be washed with lukewarm water without using any abrasive powders or corrosive substances which could scratch, stain and damage the oven. After cleaning, it is advisable to rinse thoroughly and dry.

The inside of the oven should preferably be cleaned immediately after use, when it is still warm, with hot water and soap. After cleaning, it is advisable to rinse thoroughly and dry.

- ⚠ The base of the steam cavity will remain HOT after use. Take extra care when cleaning.**

To remove the ladders unscrew the retaining screws (Fig. 6.12).

Avoid using abrasive detergents (for example cleaning powders, etc) and abrasive sponges for dishes or acids (such as lime scale remover, etc) as these could damage the enamel. If the grease spots and dirt are particularly tough to remove, use a special product for oven cleaning, following the instructions provided on the packet.

Never use a steam cleaner for cleaning inside the oven.

Use a descale product which is suitable for descaling a coffee machine. Do not use a foam cleaner.

Avoid using grinding sand mold cleaner, such as wash mat, steel wire ball, etc, as this may damage the surface.

- ⚠ Important: please do not clean the water tank in the dishwasher.**

### Descal (manual)

**Note:** Once the descale cycle is started it cannot be stopped and has to complete (approx. 30 minutes).

Touch and hold the 'Standby' button to switch the display on, use the [+ ] or [- ] buttons to select the descale function [☞].

Tap the 'Start / Pause' button to begin the descale cycle.

Fill the water tank with 0.5 litres of descaling solution (Fig. 6.13). Once the water tank is replaced the cycle will begin

The cycle will take 30 minutes to complete, at the end of which, you will be asked to change the water (Fig. 6.14) twice, whilst it is pumped through the boiler to remove the descaler solution.

Once completed the unit will beep and the display will show [End].

### Descal (automatic)

After 48 hours of boiler use your steam oven will request a descale. Follow the instructions detailed above under "Descal (manual)".

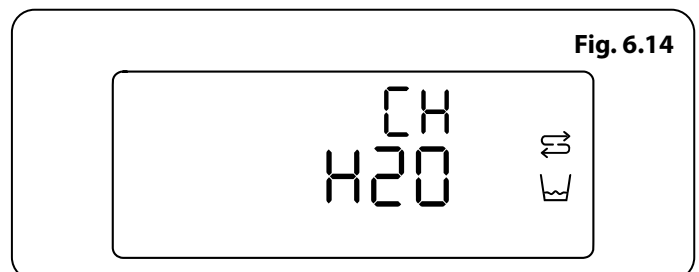
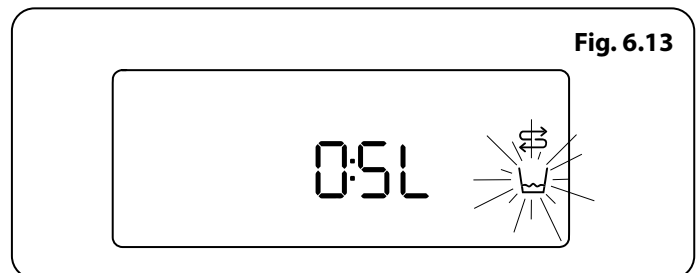
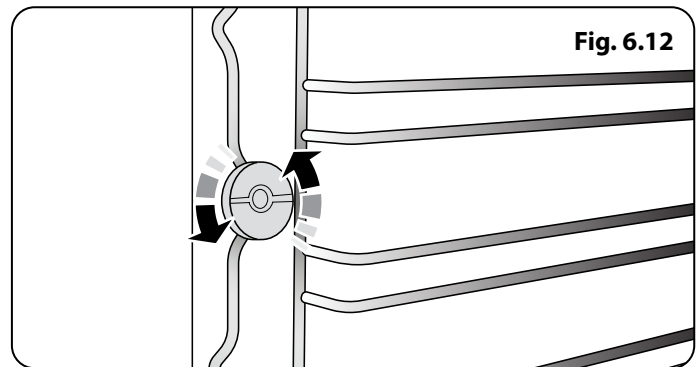

## Cleaning the water tank

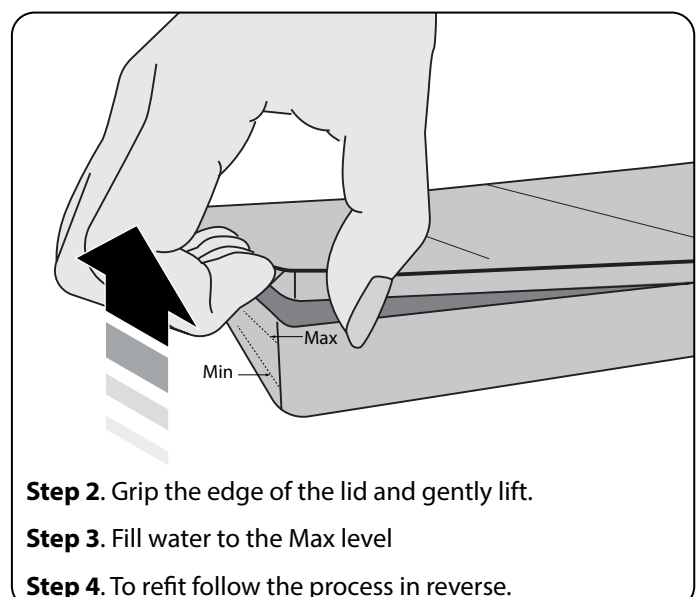
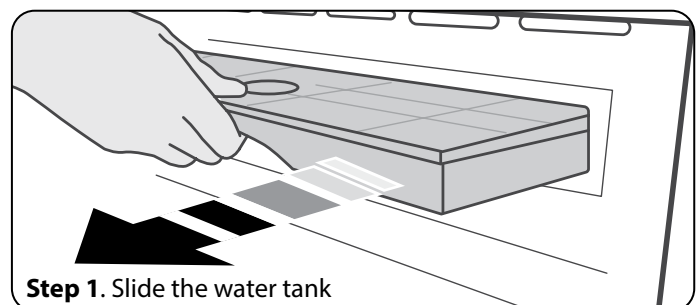

## Cleaning Table

Cleaners listed (**Table 6.1**) are available from supermarkets or electrical retailers as stated.

For enamelled surfaces use a cleaner that is approved for use on vitreous enamel.

Regular cleaning is recommended. For easier cleaning, wipe up any spillages immediately.

<b>Hotplate</b>		
<b>Part</b>	<b>Finish</b>	<b>Recommended Cleaning Method</b>
Hob top (including burner heads and caps)	Enamel, stainless steel, aluminium	Hot soapy water, soft cloth. Any stubborn stains remove gently with a nylon scourer.
Ceramic/Induction hob	Toughened glass	Hot soapy water; cream cleaner/scourer if necessary.
Griddle plate (some models only)	Non-stick surface	Allow to cool. Wash in hot soapy water. Do not use abrasive cleaners/scourers. Dishwasher.
Warming zone (some models only)	Toughened glass	Hot soapy water, cream cleaner/scourer if necessary.
<b>Outside of Cooker</b>		
<b>Part</b>	<b>Finish</b>	<b>Recommended Cleaning Method</b>
Door, door surround and storage drawer exterior	Enamel or paint	Hot soapy water, soft cloth. Any stubborn stains, remove gently with a liquid detergent.
	Stainless steel	E-cloth (electrical retailers) or microfibre all-purpose cloth (supermarket).
Sides and plinth	Painted surface	Hot soapy water, soft cloth.
Splashback/rear grille	Enamel or stainless steel	Hot soapy water, soft cloth. Cream cleaner, with care, if necessary.
Control panel	Paint, enamel or stainless steel	Warm soapy water. Do not use abrasive cleaners on lettering.
Control knobs/handles & trims	Plastic/chrome, copper or lacquered brass	Warm soapy water, soft cloth.
	Brass	Brass polish.
Oven door glass/glass lid (some models only)	Toughened glass	Hot soapy water, cream cleaner/scourer if necessary.
<b>Oven and Grill</b>		
<b>Part</b>	<b>Finish</b>	<b>Recommended Cleaning Method</b>
Sides, floor & roof of oven NOT COOK & CLEAN OVEN PANELS (see below)	Enamel	Any proprietary oven cleaner that is suitable for enamel. CAUTION: CORROSIVE/CAUSTIC OVEN CLEANERS: FOLLOW MANUFACTURER'S INSTRUCTIONS. Do not allow contact with the oven elements.
Cook & Clean oven panels (some models only)	Special enamel that partly cleans itself	This surface cleans itself at 200 °C and above, or the panels can be removed and washed with hot soapy water and a nylon brush.
Oven shelves, Handyrack, Grill trivet, Handygrill rack (some models only)	Chrome	An oven interior cleaner that is suitable for chrome. Soap filled pad. Dishwasher.
Grill pan/meat tin (some models only)	Enamel	Hot soapy water. Soap filled pad. Dishwasher.

**Table 6.1**

## 7. Troubleshooting

---

### Hotplate/Cooktop ignition or hotplate burners faulty

Is the power on? Is the clock illuminated?

If not, there maybe something wrong with the power supply.

Are the sparker (ignition electrode) or burner slots blocked by debris? See (Fig. 7.1 and Fig. 7.2).

Are the burner trim and caps correctly located? See the section on 'Cleaning'.

### Hotplate/Cooktop burners will not light

Make sure that the burner parts have been replaced correctly after wiping or removing for cleaning.

Check that there is not a problem with your gas supply. You can do this by making sure that other gas appliances you may have are working.

### Do the burners spark when you push the button?

If not, verify that the power is on by checking that the clock is illuminated.

### Steam is coming from the oven

When cooking foods with high water content (e.g. oven fries) there may be some steam visible at the rear grille.

Take care when opening the oven door, as there may be a momentary puff of steam when the oven door is opened. Stand well back and allow any steam to disperse.

### What cleaning materials are recommended for the cooker?

See the 'Cleaning' section for recommended cleaning materials.

**⚠ Never use caustic or abrasive cleaners as these will damage the surface.**

### An oven fan is noisy

The note of the oven fan may change as the oven heats up – this is perfectly normal.

### If there is an installation problem and I don't get my original installer to come back to fix it who pays?

You do. Service organisations will charge for their call outs if they are correcting work carried out by your original installer. It is in your interest to track down your original installer.

### Power failure

In the event of a failure in the electrical supply, remember to reset the clock to make sure that the timed oven continues to operate.

### Food is cooking too slowly, too quickly, or burning

Cooking times may differ from your previous oven.

Check that you are using the recommended temperatures and shelf positions – see the oven cooking guide. The oven control settings and cooking times are intended to be used only as a guide.

Individual tastes may require the temperature to be altered either way, to get the results you want.

### The oven is not cooking evenly

**DO NOT** use a baking tray with dimensions larger than those specified in the section on 'General Oven Tips'.

If you are cooking a large item, be prepared to turn it round during cooking.

If two shelves are used, check that space has been left for the heat to circulate. When a baking tray is put into the oven, make sure that it is placed centrally on the shelf.

Check that the door seal is not damaged and that the door catch is adjusted so that the door is held firmly against the seal.

A dish of water when placed on the shelf should be the same depth all over. (For example, if it is deeper at the back, then the back of the cooker should be raised up or the front lowered.) If the cooker is not level, arrange for your supplier to level it for you.

### Oven not coming on

Is the power on? Is the clock illuminated? If not, there may be something wrong with the power supply.

Is the cooker supply on at the isolator switch?

Has the time of day been set?

### Oven temperature getting hotter as the cooker gets older

If turning the temperature down using the oven control knob has not worked, or has only worked for a short time, then you may need a new thermostat. This should be fitted by a qualified service person.

### The fascia gets hot when I use the oven or grill

The cooker is cooled by a fan. If the fascia becomes excessively hot when the cooker is in use then the cooling fan may have failed. Should this occur please contact your installer, a qualified repair engineer or Customer Service to arrange for its repair.

### The knobs get hot when I use the oven or the grill. Can I avoid this?

Yes, this is caused by heat rising from the oven or the grill, and heating them up. **DO NOT** leave the oven door open.

Make sure that the grill pan is pushed right back to the 'back stop' when grilling.

Always grill with the grill compartment door open.

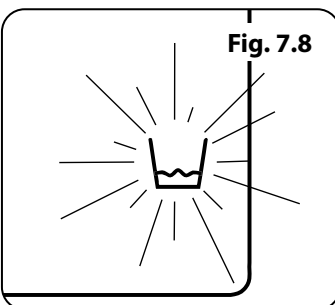
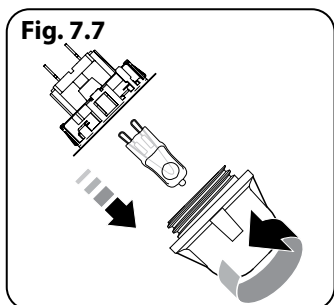
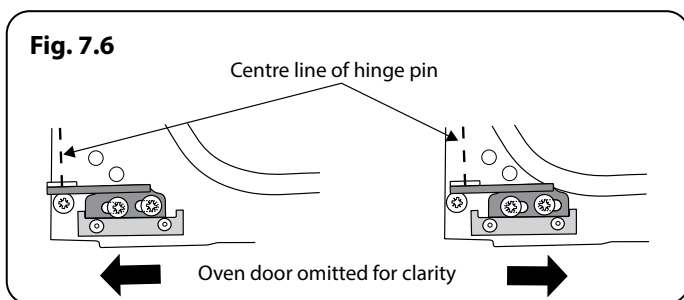
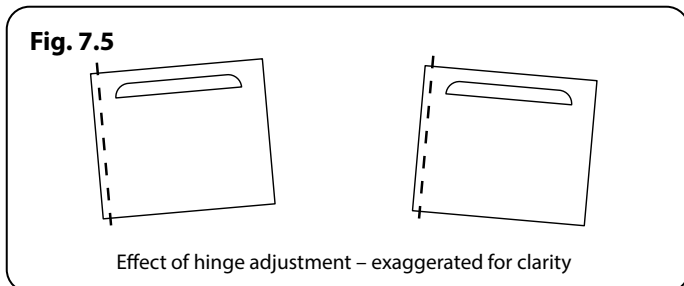
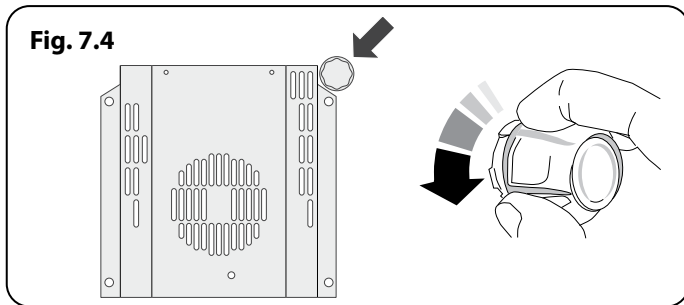
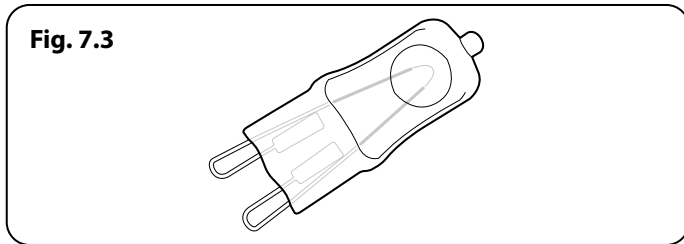
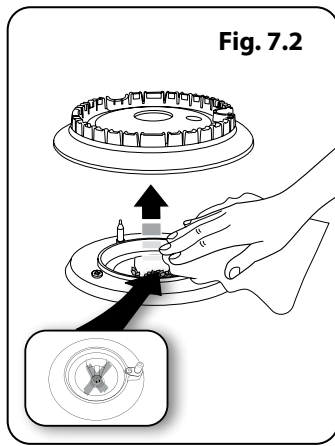
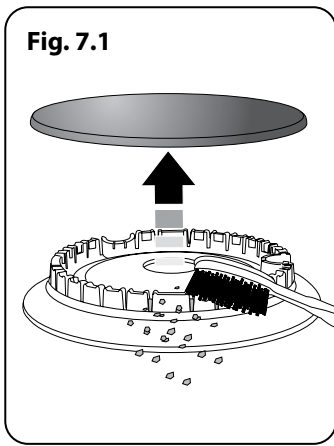

**Multifunction oven light is not working**

The bulb has probably burnt out. You can buy a replacement bulb (which is not covered under the warranty) from a good electrical shop. Ask for a **40W - 230V** halogen lamp (G9) (**Fig. 7.3**).

Before removing the existing bulb, turn off the power supply and make sure that the oven and bulb have cooled. Open the oven door and remove the oven shelves.

Remove the bulb cover by turning it a quarter turn, counter-clockwise. It may be very stiff (**Fig. 7.4**).

Pull the existing bulb to remove it. When handling the replacement bulb, avoid touching the glass with your fingers, as oils from your hands can cause premature failure. Push, click in the replacement bulb.

Replace the bulb cover by turning it a quarter turn, clockwise. Turn on the circuit breaker and check that the bulb now lights.

**The left-hand oven door is misaligned**

The bottom hinge of the left-hand oven door can be adjusted to alter its angle (**Fig. 7.5**).

Loosen the bottom hinge fixing screws and use the notch and a flat bladed screwdriver to move the position of the hinge to set the hinge position (**Fig. 7.6**).

Retighten the hinge screws.

**Steam cavity light is not working**

The bulb has probably burnt out. You can buy a replacement bulb (which is not covered under the warranty) from a good electrical shop. Ask for a **25W - 230V** halogen lamp (G9) (**Fig. 7.3**).

**WARNING:** Before removing the existing bulb, turn off the power supply and make sure that the oven and bulb have cooled. Open the oven door and remove the oven shelves.

Remove the bulb cover by turning it, counter-clockwise. It may be very stiff (**Fig. 7.7**).

Pull the existing bulb to remove it. When handling the replacement bulb, avoid touching the glass with your fingers, as oils from your hands can cause premature failure. Push, click in the replacement bulb.

Replace the bulb cover by turning it clockwise. Turn on the circuit breaker and check that the bulb now lights.

**Moisture visible on the steam cavity door**

This is normal. Wipe away excess moisture once cooking is complete.

**The Steam oven beeps and makes a noise but there is the flashing of the start/pause button and another flashing symbol (Fig. 7.8).**

Problem: Low water level in the water tank or water tank is not in place. The steam cavity will not operate.

To fix this, place the water tank in the correct position ensuring that the water tank is fully engaged and an audible click is heard.

## Error Codes

<b>Multifunction oven</b>		
<b>Error Code</b>	<b>Error description</b>	<b>Comment</b>
HE 1	Oven sensor NTC short circuit or open circuit	
HE 2	Meat probe short circuit	Not applicable
HE 3	Communication problem between UI and power PCB	

<b>Steam cavity</b>		
<b>Error Code</b>	<b>Error description</b>	<b>Comment</b>
HE 1	Oven sensor NTC short circuit or open circuit	
HE 2	Water boiler sensor open circuit or short circuit	
HE 3	Water level sensor switch cut - Hi or Low Sensor	
HE 4	After press button 8, door switch short circuit	
HE 5	Water tank empty	
HE 6	Failure of the door switch (short circuit)	

## INSTALLATION

Check the appliance is electrically safe and gas sound when you have finished.

# 8. Installation

## Dear Installer

Before you start your installation, please complete the details below, so that, if your customer has a problem relating to your installation, they will be able to contact you easily.

<b>Installer's Name</b>
<b>Installer's Company</b>
<b>Installer's Telephone Number</b>
<b>Appliance Serial Number</b>

## Safety Requirements and Regulations

- ⚠ This cooker must be installed in accordance with the relevant instructions in this booklet, with the relevant national and local regulations, and with the local gas and electricity supply companies' requirements.**
- ⚠ If the appliance is to be installed in Switzerland, the following regulations and directives should be observed:**
  - SVGW - Gas principles G1: Gas installation.
  - EKAS - Form. 1942: Liquid gas directive, Part 2.
  - Cantonal instances regulations (e.g. fire safety regulators).
- ⚠ This cooker is a Class 2 Subclass 1 appliance.**
- ⚠ Before installation, make sure that the cooker is suitable for your gas type and supply voltage. See the data badge.**
- ⚠ The appliance must be installed in accordance with the regulations in force and only in a well-ventilated space.**
- ⚠ Read the instructions before installing or using this appliance.**

**⚠ In your own interest and that of safety, it is law that all gas appliances be installed by competent persons. Failure to install the appliance correctly could invalidate any warranty or liability claims and lead to prosecution.**

**⚠ This appliance can be converted for use on another gas.**

## Provision of ventilation

This appliance is not connected to a combustion products evacuation device. Particular attention shall be given to the relevant requirements regarding ventilation.

All rooms require a window that can be opened, or equivalent, while some rooms require a permanent vent in addition to the window.

## Location of cooker

The cooker may be installed in a kitchen/kitchen diner but **NOT** in a room containing a bath or shower.

This appliance is designed for domestic cooking only. Use for any other purpose could invalidate any warranty or liability claim.

Note: An appliance for use on LPG must not be installed in a room or internal space below ground level, e.g. in a basement.

## Conversion

A conversion kit for another gas is available for the cooker.

If the appliance is to be converted to another gas we recommend that this is carried out before installation.

**⚠ We recommend an overpressure shut-off device or pressure relief valve be used in any LPG installation to prevent exposure of downstream fittings / appliances to excessive pressure (over 75mbar) in event of regulator failure.**

After converting the appliance, please attach the Gas Conversion sticker over the appropriate area of the data badge – this will identify the gas type for which the appliance is now set.



## INSTALLATION

Check the appliance is electrically safe and gas sound when you have finished.

### You will need the following equipment to complete the cooker installation satisfactorily:

- Stability bracket: If the cooker is to be supplied with gas through a flexible hose, a stability bracket or chain must be fitted. **These are not supplied with the cooker** but are available at most builders' merchants.
- Gas pressure tester/manometer.
- Flexible gas hose: Must be in accordance with the relevant standards.
- Multimeter: For electrical checks.

### You will also need the following tools:

1. Electric drill
2. Masonry drill bit (only required if fitting the cooker on a stone or concrete floor)
3. Wall plugs (only required if fitting the cooker on a stone or concrete floor)
4. Steel tape measure
5. Cross head screwdriver
6. Flat head screwdriver
7. Spirit level
8. Pencil
9. Adjustable spanner
10. Screws for fitting stability bracket
11. 13 mm spanner or socket wrench

### Checking the parts:

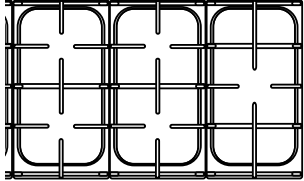
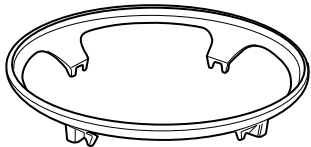
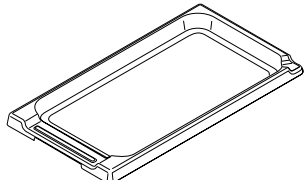
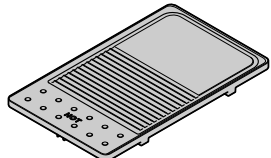
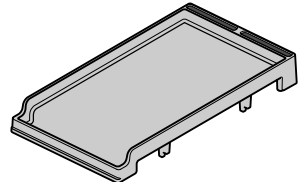
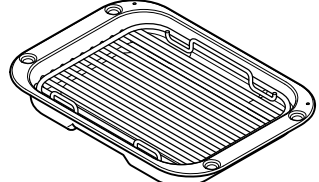
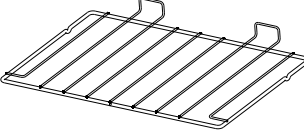
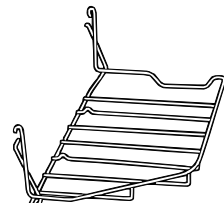
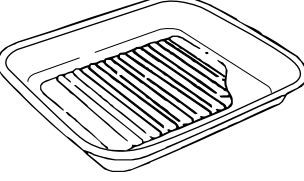
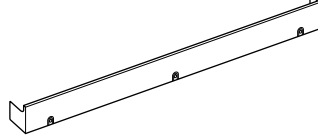
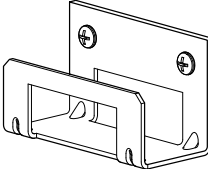
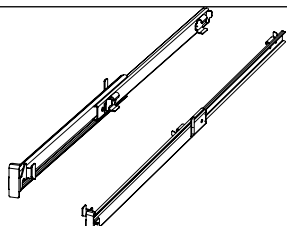
3 pan supports	Wok cradle (Supplied)
	
Griddle plate (Supplied)	Griddle Plate (Optional)
	
Teppanyaki (Optional)	Grill pan and trivet
	
Flat shelves	Handyrack (Optional)
	
Roasting tin (Optional)	Plinth
	
Stability location bracket	2 x set of Telescopic runners (Supplied)
	

## INSTALLATION

Check the appliance is electrically safe and gas sound when you have finished.

### Positioning the Cooker

**Fig. 8.1** and **Fig. 8.2** shows the minimum recommended distance from the cooker to nearby surfaces.

The cooker should not be placed on a base.

**Fig. 8.1** and **Fig. 8.2** Cookers installed into recess: The cooker must have side clearance **ABOVE** hob level of 75mm up to a height of 410mm. This can be reduced to 25mm if the surface is made from a non-combustible material.

A minimum space of 650 mm is required between the top of the hob and a horizontal combustible surface.

\*Any cookerhood should be installed in accordance with the hood manufacturer's instructions.

\*\*Any splashback must be fitted in accordance with the manufacturers instructions. Allowance should be made for the additional height of the flue trim, which is fitted to the cooker hob.

Surfaces of furniture and walls at the sides and rear of the appliance should be heat, splash and steam resistant. Certain types of vinyl or laminate kitchen furniture are particularly prone to heat damage and discolouration. We cannot accept responsibility for damage caused by normal use of the cooker to any material that de-laminates or discolours at temperatures less than 65°C above room temperature.

**DO NOT** box the cooker in – it must be possible to move the cooker in and out for cleaning and servicing.

To allow the oven doors to open, a clearance of 130 mm is required if the cooker is near a corner of the kitchen (**Fig. 8.3**). The actual opening of the doors is slightly less, but this allows for some protection of your hand as you open the door.

### Moving the Cooker

**⚠ On no account try and move the cooker while it is plugged into the electricity supply.**

**⚠ The cooker is very heavy, so take great care.**

We recommend that two people manoeuvre the cooker. Make sure that the floor covering is firmly fixed, or removed, to prevent it being disturbed when moving the cooker around.

To help you, there are two levelling rollers at the back, and two screw-down levelling feet at the front.

Remove the polystyrene base pack. From the front, tilt the cooker backwards and remove the front half of the polystyrene base (**Fig. 8.4**).

Repeat from the back and remove the rear half of the polystyrene base.

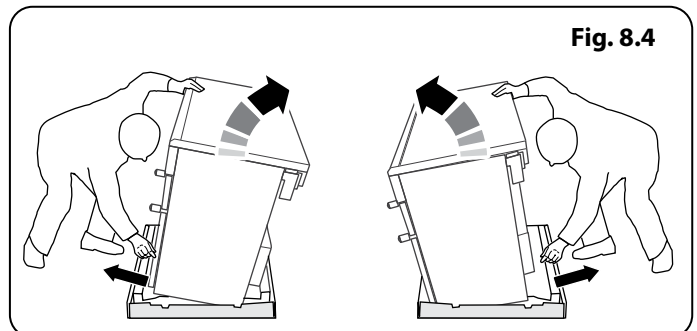
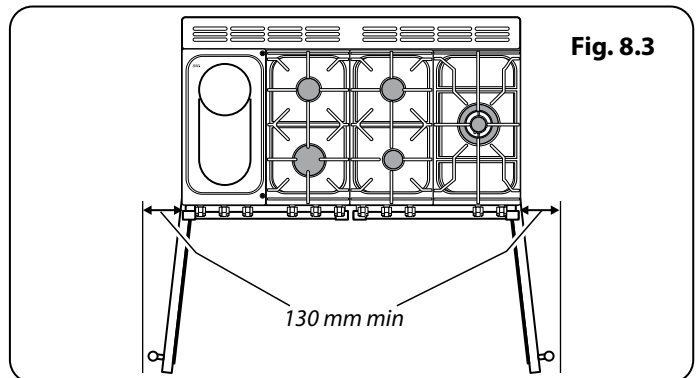
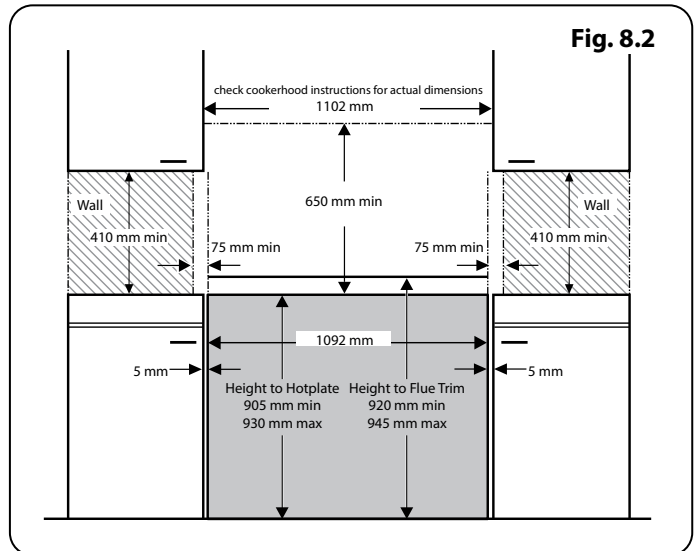
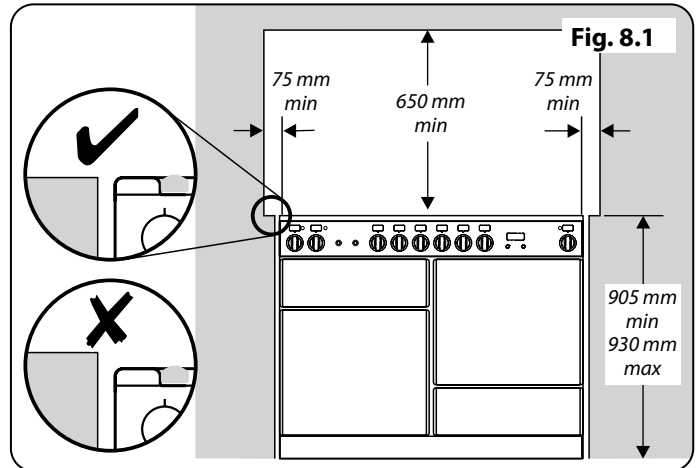

## INSTALLATION

Check the appliance is electrically safe and gas sound when you have finished.

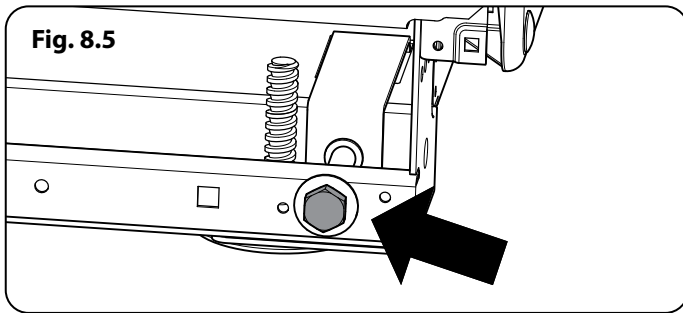

### Lowering the Two Rear Rollers

To adjust the height of the rear of the cooker, first fit a 13 mm spanner or socket wrench onto the hexagonal adjusting nut (**Fig. 8.5**). Rotate the nut – clockwise to raise – counter-clockwise to lower.

Make 10 complete (360°) turns clockwise.

Make sure you lower **BOTH REAR ROLLERS**.

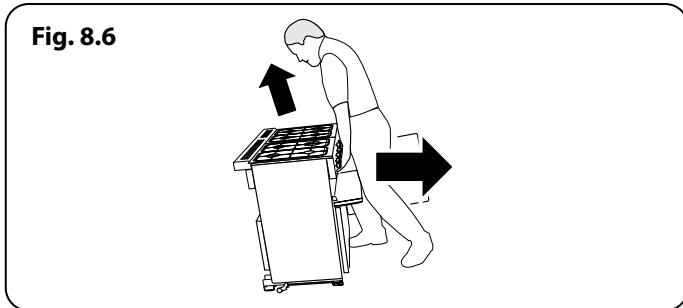

### Completing the Move

Unfold the rear edge of the cardboard base tray. Open the oven doors so that you can get a good grip on the bottom of the fascia panel as you move the oven (**Fig. 8.6**).

Carefully push the cooker backwards off the base tray. Remove the base tray.

Position the cooker close to its final position, leaving just enough space to get behind it.

**⚠ DO NOT use the door handles or control knobs to manoeuvre the cooker.**

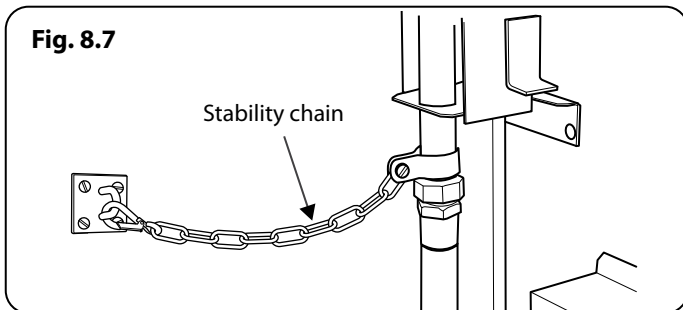

### Fitting the Stability Bracket or Chain

Unless otherwise stated, a cooker using a flexible gas connector must be secured with a suitable stability device.

Suitable stability devices are shown in **Fig. 8.7**, **Fig. 8.8**, **Fig. 8.9** and **Fig. 8.10**.

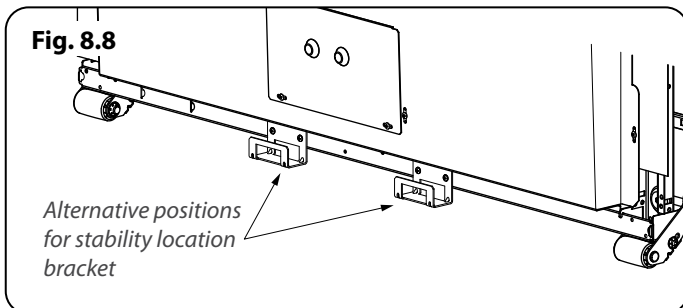

If you are using a stability chain (**Fig. 8.7**) then the chain should be kept as short as is practicable and fixed firmly to the rear of the cooker.

If you are using a stability bracket; first attach the bracket location device to the rear of the cooker (**Fig. 8.8**). Then adjust the bracket to engage through the slot of the device (**Fig. 8.9** and **Fig. 8.10**).

### Repositioning the Cooker Following Connection

If you need to move the cooker once it has been connected then you need to unplug it and, having gripped under the fascia panel and lifted the front of the cooker slightly (**Fig. 8.6**), you need to check behind the cooker to make sure that the gas hose is not caught.

As you progress, make sure that both the electricity cable and gas hose always have sufficient slack to allow the cooker to move.

With a stability chain fitted, release it as you ease the cooker out. Do not forget to refit it when you replace the cooker.

When you replace the cooker, again check behind to make sure that the electricity cable and gas hose are not caught or trapped.

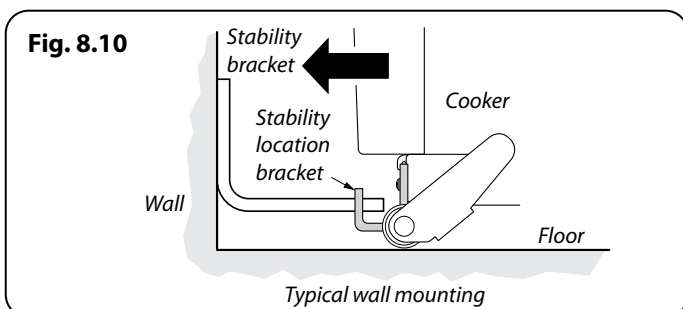
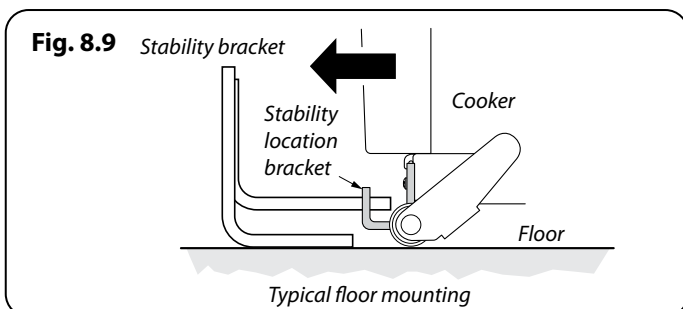

## INSTALLATION

Check the appliance is electrically safe and gas sound when you have finished.

**Fig. 8.11**

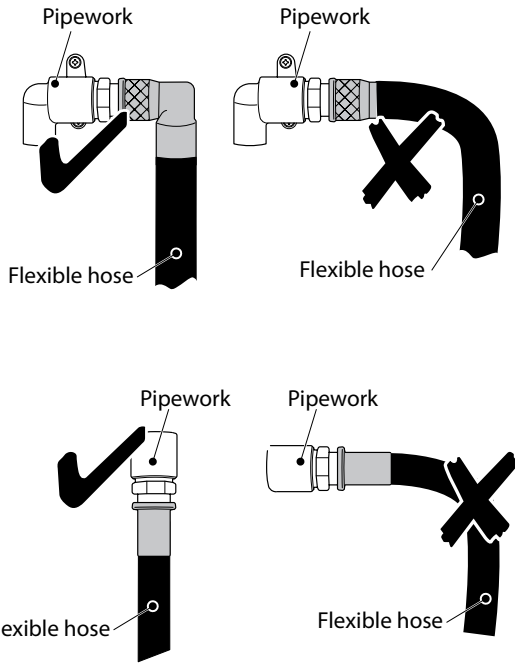

**Fig. 8.12**

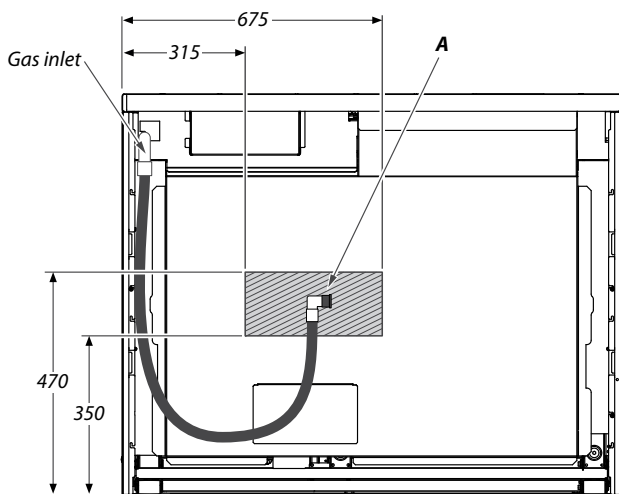

All dimensions in millimetres

## Levelling

You are recommended to use a spirit level on a shelf in one of the ovens to check for level.

Place the cooker in its intended position taking care not to twist it within the gap between the kitchen units as damage may occur to the cooker or the units.

The front feet and rear rollers can be adjusted to level the cooker.

To adjust the height of the rear of the cooker use a 13 mm spanner or socket wrench to turn the adjusting nuts at the front bottom corners of the cooker.

To set the front, turn the feet bases to raise or lower.

## Gas Connection

This must be in accordance with the relevant standards.

The flexible hose (not supplied with the cooker) must be in accordance with the relevant standards. Hoses may be purchased at most builders' merchants.

The connector is located just below the hotplate level at the rear of the cooker. If in doubt contact your supplier.

The rear cover boxes limit the position of the supply point.

Because the height of the cooker can be adjusted and each connection is different, it is difficult to give precise dimensions.

Although a 900 mm hose can be used, a 1100 mm hose will allow slightly more flexibility in the positioning of the bayonet and make moving the cooker easier.

The hose should be fitted so that both inlet and outlet connections are vertical so that the hose hangs downwards in a 'U' shape.

Ideally the hose supply connection should be within the shaded area 'A' (**Fig. 8.12**).

Screw connect the threaded end of the hose into the gas inlet.

After completing the gas connection, make sure that the cooker is gas sound with a pressure test.

## Pressure Testing

The gas pressure can be measured at one of the hotplate burner injectors (not the wok burner).

Lift off a burner head. Fit the pressure gauge to the injector. Turn on and light one of the other hotplate burners.

Turn on the control knob for the burner with the pressure gauge fitted to let gas through.

**See the data badge for test pressures.**

Turn off the burners. Make sure that you reassemble the burner top in the correct way on the burner body.

## INSTALLATION

Check the appliance is electrically safe and gas sound when you have finished.

### Electrical Connection

This appliance must be installed by a suitably qualified electrician to comply with the relevant electrical regulations, and also the local electricity supply company requirements.

**⚠ WARNING: THE APPLIANCE MUST BE EARTHED.**

**NOTE:** The cooker must be connected to the correct electrical supply as stated on the voltage label on the cooker, through a suitable cooker control unit incorporating a double-pole switch, having a contact separation of at least 3 mm in all poles.

**⚠ The cooker MUST NOT be connected to an ordinary domestic power point.**

Access to the mains terminal is gained by removing the electrical terminal cover box on the back panel. Connect the mains cable to the correct terminals for your electrical supply type (**Fig. 8.13** and **Fig. 8.14**). Check that the links are correctly fitted and that the terminal screws are tight. Secure the mains cable using the cable clamp.

### Final Checks

#### Hob Check

Check each cooking zone in turn. Be sure to use pans of the correct size and material.

#### Grill Check

Turn on the grill control and check that the grill heats up.

#### Oven Check

Set the clock as described earlier, and then turn on the ovens. Check the oven fans start to turn and that the ovens heat up.

### Final Fitting

#### Fitting the Plinth

Loosen the 3 screws along the front bottom edge of the cooker. Twist and fit each end keyhole over their respective screws. Tighten the fixing screws (**Fig. 8.15**).

### Customer Care

**Installer:** Please complete your details in this guide, inform the user how to operate the cooker and hand over the instructions.

Thank you.

#### Current Operated Earth Leakage Breakers

The combined use of your induction cooker and other domestic appliances may cause nuisance tripping, so we recommend that the cooker is protected on an individual RCD (Residual Current Device) or RCBO (Residual Current Breaker with Overload).

**IF IN DOUBT, PLEASE CONSULT A SUITABLY QUALIFIED ELECTRICIAN.**

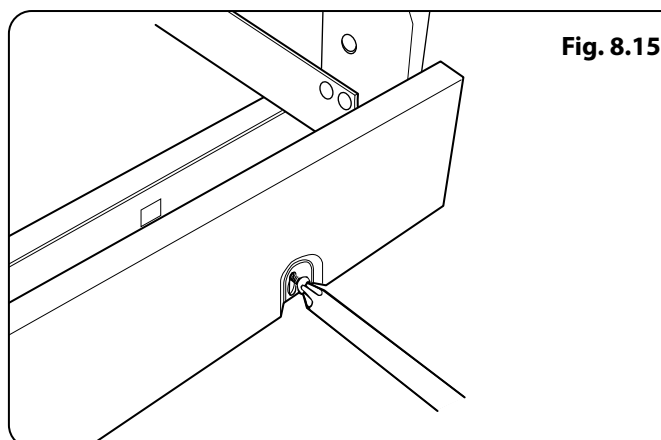
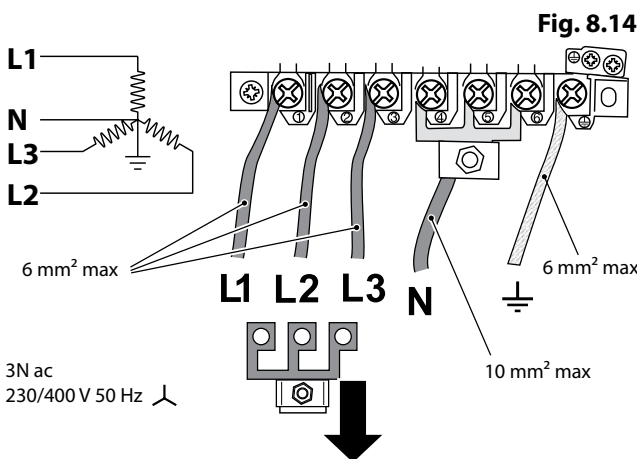
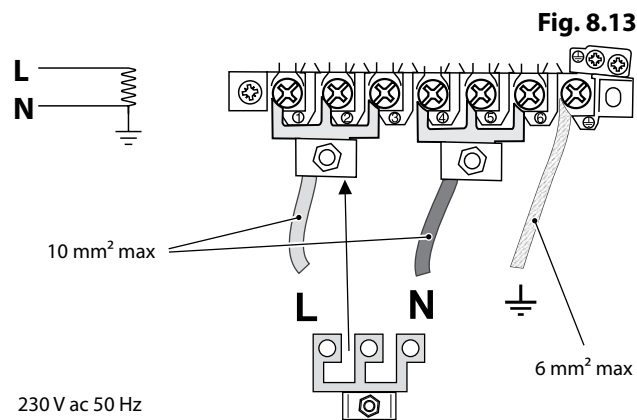

# 9. Circuit Diagram

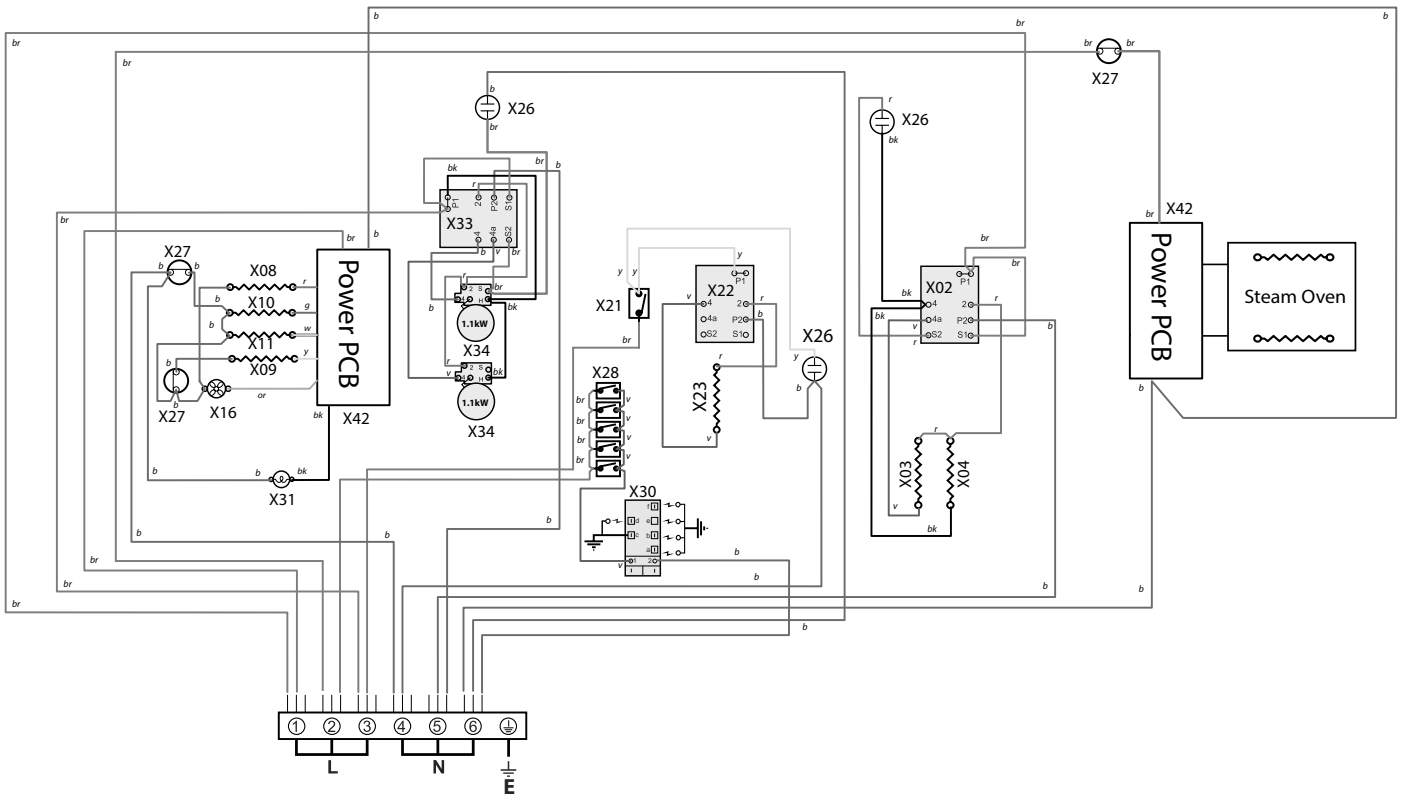

## Key

The connections shown in the circuit diagram are for single-phase. The ratings are for 230V 50Hz.

Code	Description
<b>X02</b>	Grill Energy Regulator
<b>X03</b>	Left Hand Grill Element
<b>X04</b>	Right Hand Grill Element
<b>X08</b>	Left Hand Oven Base Element
<b>X09</b>	Left Hand Oven Fan Element
<b>X10</b>	Left Hand Oven Top Outer Element
<b>X11</b>	Left Hand Oven Top Inner Element
<b>X16</b>	Oven Fan
<b>X21</b>	Proving Drawer Switch
<b>X22</b>	Proving Drawer Energy Regulator
<b>X23</b>	Proving Drawer Element

Code	Description
<b>X26</b>	Neon
<b>X27</b>	Thermal Cut-Out
<b>X28</b>	Ignition Switches
<b>X30</b>	Spark Generator
<b>X31</b>	Oven Light
<b>X33</b>	Hob Energy Regulator
<b>X34</b>	Hob Element
<b>X42</b>	Power PCB (Steam and MF Oven)

Code	Colour
<b>b</b>	Blue
<b>br</b>	Brown
<b>bk</b>	Black
<b>or</b>	Orange
<b>r</b>	Red
<b>v</b>	Violet
<b>w</b>	White
<b>y</b>	Yellow
<b>g/y</b>	Green/Yellow
<b>gr</b>	Grey

# Power PCB

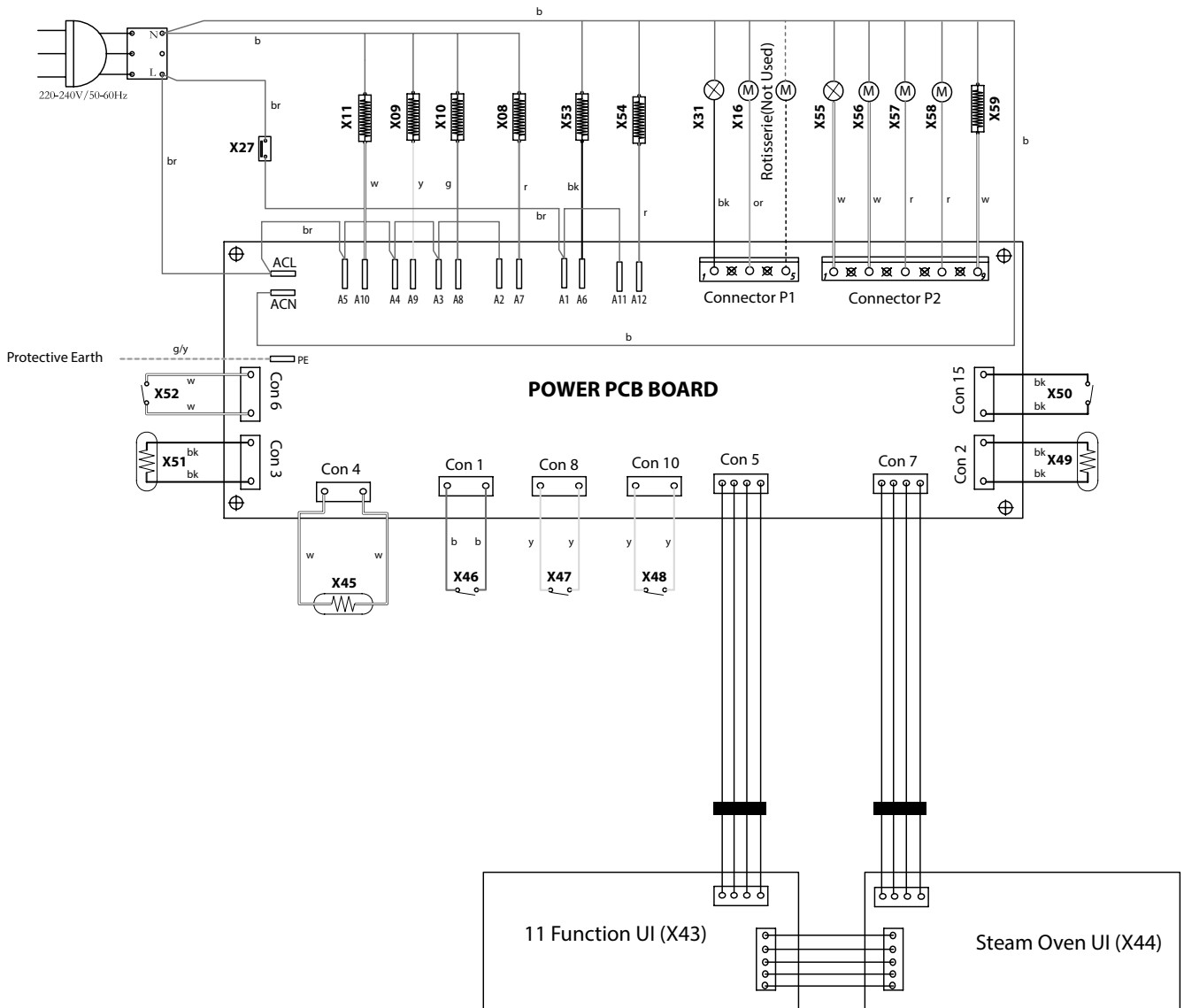

## Key

The connections shown in the circuit diagram are for single-phase. The ratings are for 230V 50Hz.

Code	Description
<b>X43</b>	User Interface (UI) MF Oven
<b>X44</b>	User Interface (UI) Steam Cavity
<b>X45</b>	Water Boiler Sensor
<b>X46</b>	Water Tank Switch
<b>X47</b>	Water Sense (Low)
<b>X48</b>	Water Sense (High)
<b>X49</b>	MF Oven Temperature Sensor
<b>X50</b>	MF Oven Door Sensor
<b>X51</b>	Steam Cavity Temperature Sensor
<b>X52</b>	Steam Cavity Door Sensor

Code	Description
<b>X53</b>	Water Boiler Element
<b>X54</b>	Steam Cavity Top Element
<b>X55</b>	Steam Cavity Light
<b>X56</b>	Water Pump In
<b>X57</b>	Water Pump Out
<b>X58</b>	Steam Cavity Cooling Fan
<b>X59</b>	Steam Cavity Base Element

Code	Colour
<b>b</b>	Blue
<b>br</b>	Brown
<b>bk</b>	Black
<b>or</b>	Orange
<b>r</b>	Red
<b>v</b>	Violet
<b>w</b>	White
<b>y</b>	Yellow
<b>g/y</b>	Green/Yellow
<b>gr</b>	Grey

## 10. Technical Data

**INSTALLER:** Please leave these instructions with the user. **DATA BADGE LOCATION:** Cooker back, serial number repeater badge below oven door opening. **COUNTRY OF DESTINATION:** GB, IE, FR, NL, DE, SE, BE.

**Gas Category & Pressure Settings** This appliance is supplied set for one of the gas categories listed in the table below, dependant on country of destination.

Category	Country	Natural Gas	L.P. Gas
Cat II <sub>2H3+</sub>	GB, IE	G20 20mbar	G30 butane 29mbar G31 propane 37mbar
Cat II <sub>2E3B/P</sub> Cat II <sub>2ELL3B/P</sub>	DE	G20 20mbar G25 20mbar	G30 butane 29mbar G31 propane 29mbar G30 butane 50mbar G31 propane 50mbar
Cat II <sub>2E+3+</sub>	FR, BE	G20 20/25mbar	G30 butane 29mbar G31 propane 37mbar
Cat II <sub>2H3B/P</sub>	SE, CH	G20 20mbar	G30 butane 29mbar G31 propane 29mbar
Cat II <sub>2L3B/P</sub>	NL	G25 25mbar	G30 butane 29mbar G31 propane 29mbar

### Hotplate Ratings

See the data badge for information on the gas and pressure for which the appliance is set.

If a conversion is required follow the conversion instructions.

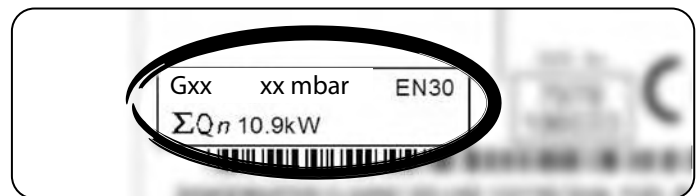

Hotplate	Bypass Screw*	Natural Gas G20 20 mb		L.P. Gas 29 / 37 mb	
			Injector		Injector
Wok burner	62	4,0 kW	148	4,0 kW (291 g/h)	103
Rapide/ Large Burner	40	3,0 kW	134	3,0 kW (218 g/h)	87
Semi Rapide / Medium Burner	32	1,7 kW	109	1,7 kW (124 g/h)	68
Auxiliary / Small Burner	28	1,0 kW	75	1,0 kW (73 g/h)	51
Hotplate	Bypass Screw*	Natural Gas G25 25 mb		L.P. Gas 29 mb	
			Injector		Injector
Wok burner	62	4,0 kW	152	4,0 kW (291 g/h)	103
Rapide/ Large Burner	40	3,0 kW	135	3,0 kW (218 g/h)	87
Semi Rapide / Medium Burner	32	1,7 kW	105	1,7 kW (124 g/h)	68
Auxiliary / Small Burner	28	1,0 kW	76	1,0 kW (73 g/h)	51
Hotplate	Bypass Screw*	Natural Gas G25 20 mb		L.P. Gas 50 mb	
			Injector		Injector
Wok burner	62	4,0 kW	163	4,0 kW (291 g/h)	86
Rapide/ Large Burner	40	3,0 kW	141	3,0 kW (218 g/h)	81
Semi Rapide / Medium Burner	32	1,7 kW	113	1,7 kW (124 g/h)	60
Auxiliary / Small Burner	28	1,0 kW	85	1,0 kW (73 g/h)	46

\* The valves in this cooker are fitted with adjustable bypass screws. If the appliance is supplied set for natural gas, the bypass screws will be unscrewed. For LPG conversion the bypass screws must be screwed all the way down.

If the appliance is supplied set for LPG, the bypass screws will be screwed all the way down. For Natural Gas conversion the bypass screws must be screwed out in accordance with the instruction in the conversion kit supplied.



## Connection

Electric	230/400V 50 Hz
----------	----------------

## Dimensions

Model	NEXUS 110 Dual Fuel / Steam	
Overall height	minimum 905 mm	maximum 930 mm
Overall width	1092 mm	
Overall depth	604 mm excluding handles, 649 mm including handles	
Minimum height above the hotplate	650 mm	

### Hotplate energy saving tips

- Use cookware with a flat base.
- Use the correct size cookware.
- Use cookware with a lid.
- Minimise the amount of liquid or fat.
- When liquid starts boiling, reduce the setting.
- Consumption is based on G30.

### Oven energy saving tips

- Cook meals together, if possible.
- Keep the pre-heating time short.
- Do not lengthen cooking time.
- Do not open the oven door during the cooking period.
- Do not forget to turn the appliance off at the end of cooking.

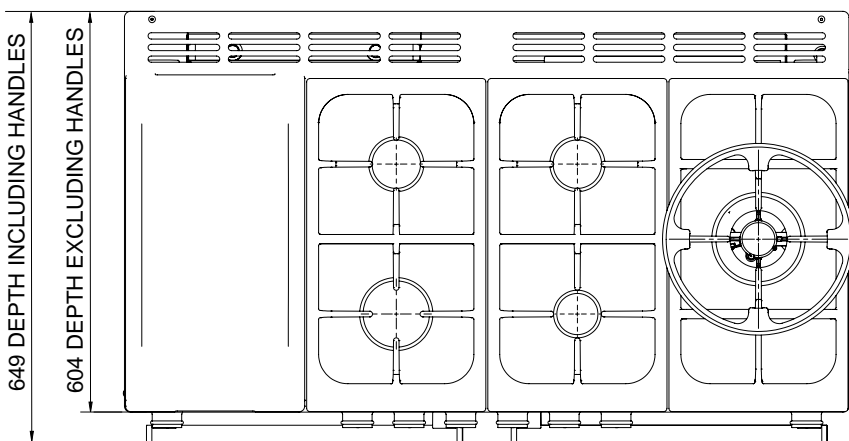
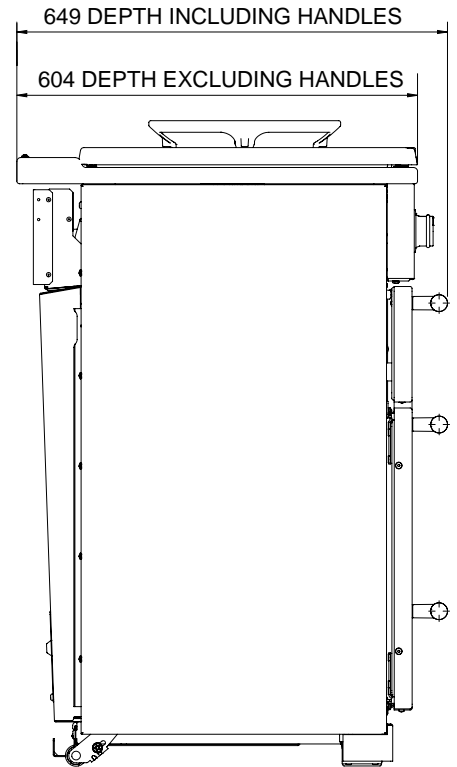
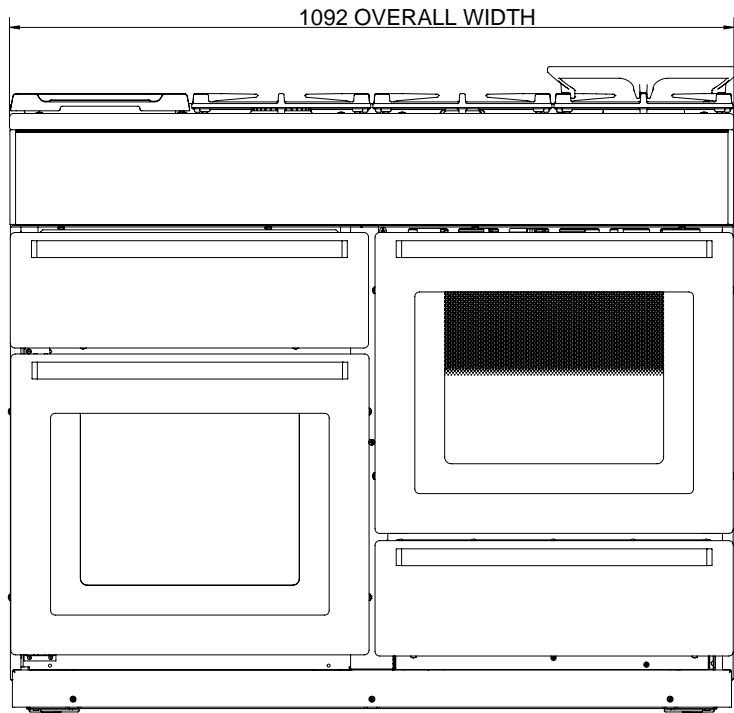

## Hotplate Efficiency

Brand	Falcon
Model Identification	Nexus
Size	110
Type	Dual Fuel / Steam

Type of Hob	Gas
Number of gas burners	5
Auxiliary / Small Burner (EE gas burner)	-
Semi Rapide / Medium Burner (EE gas burner)	58%
Semi Rapide / Medium Burner (EE gas burner)	58%
Rapide / Large Burner (EE gas burner)	56%
Rapide / Large Burner (EE gas burner)	-
Wok (EE gas burner)	54%
Wok (EE gas burner)	-
Hotplate EE gas hob (*)	-

Type of Hob	Radiant
Number of electric zones	2
Zone 1 - Ø cm	14.5
Heating Technology	
Energy Consumption (EElectric cooking) - Wh/kg	180
Zone 2 - Ø cm	14.5
Heating Technology	
Energy Consumption (EElectric cooking) - Wh/kg	180
Energy Consumption (EElectric hob) - Wh/kg (*)	-

Information marked thus (\*) is not required with mixed fuel hobs

## Oven Data

Brand	Falcon	
Model identification	Nexus	
Type of oven	Electric	
Mass	kg	133
Number of cavities	2	
<b>Left-hand Efficiency</b>		
Fuel type	Electric	
Cavity type	Multifunction	
Power - conventional	2.2	
Power - forced air convection	2.5	
Volume	Litres	79
Energy consumption (electricity) - conventional	kWh / cycle	1.01
Energy consumption (electricity) - forced air convection	kWh / cycle	0.88
Energy efficiency index - conventional	114	
Energy efficiency index - forced air convection	100	
Energy efficiency index - ECO mode	kWh / cycle	87
Energy class	A	

<b>Additional Information</b>		
The oven complies with EN 60350-1		
Maximum output @ 230V 50Hz		
Conventional	2.2 kW	
Multifunction	2.5 kW	
Multifunction (with Rapid Response)	-	
Forced Air Convection	2.5 kW	
Grill	2.3 kW	
Slow Oven	-	
Bread Proving Drawer	0.2 kW	

<b>Maximum total electrical load at 230 V</b> (approximate total including hob, oven lights, oven fan, etc.):	6.95 kW *
---	-----------

\* Arithmetic mean value when measured under full load stabilised conditions, Clause 10 EN 60335.

## NOTE

---

## NOTE

---

## NOTE

---

Clarence Street, Royal Leamington Spa,  
Warwickshire, CV31 2AD, England.  
[www.falconworld.com](http://www.falconworld.com)

