



# USER GUIDE & INSTALLATION INSTRUCTIONS

1092 Continental Dual Fuel

U110979-04a



# Contents

---

<b>1. Before You Start...</b>	<b>1</b>	<b>7. Installation</b>	<b>20</b>
Personal Safety	1	Dear installer	20
Electrical Connection Safety	1	Safety requirements and regulations	20
If You Smell Gas	3	Provision of ventilation	20
Peculiar Smells	3	Conversion	20
Cooling Fan	3	Positioning the cooker	22
Ventilation	3	Moving the cooker	22
Maintenance	3	Levelling	23
Grill/Glide-out Grill™ Care	5	Fitting a stability bracket or chain	23
Cooker Care	5	Repositioning the cooker	
Cleaning	6	following connection	24
<b>2. Cooker overview</b>	<b>7</b>	Gas connection	24
Hotplate burners	7	Electrical connection	25
Wok cradle	8	Final checks	26
The ovens	9	Final fitting	26
Accessories	12	Customer care	26
Oven Lights	12	Fitting the drawer	27
Storage	12	Removing the drawer	27
<b>3. Cooking tips</b>	<b>13</b>	<b>8. Circuit diagram</b>	<b>28</b>
<b>4. Cooking Table</b>	<b>14</b>	<b>9. Technical Data</b>	<b>29</b>
<b>5. Cleaning your cooker</b>	<b>15</b>		
Essential Information	15		
Main top	16		
Control panel and oven doors	16		
Ovens	16		
Cleaning table	17		
<b>6. Troubleshooting</b>	<b>18</b>		



# 1. Before You Start...

---

Your cooker should give you many years of trouble-free cooking if installed and operated correctly. It is important that you read this section before you start.

## Personal Safety

This appliance is for cooking purposes only. It must not be used for other purposes, for example heating a room. Using it for any other purpose could invalidate any warranty or liability claim. Besides invalidating claims this wastes fuel and may overheat the control knobs.

This cooker must be installed in accordance with the relevant instructions in this booklet and with the national and local regulations as well as the local gas and electricity supply companies' requirements.

- This appliance can be used by children aged from 8 years and above and persons with reduced physical, sensory or mental capabilities or lack of experience and knowledge if they have been given supervision or instruction concerning use of the appliance in a safe way and understand the hazards involved.
- **WARNING:** Children **less** than 8 years of age should be kept away unless continuously supervised. Children shall not play with the appliance. Cleaning and user maintenance shall not be made by children without supervision.
- The cooker should not be placed on a base.
- This appliance is designed for domestic cooking only. Use for any other purpose could invalidate any warranty or liability claim.
- Before operating the ovens please refer to the oven shelf installation, in the Accessories section.
- **WARNING:** The appliance and its accessible parts become hot during use and will retain heat even after you have stopped cooking. Care should be taken to avoid touching heating elements. Children less than 8 years of age shall be kept away unless continuously supervised.
- **CAUTION:** A long term cooking process has to be supervised from time to time. A short term cooking process has to be supervised continuously.
- At the risk of fire **DO NOT** store items on the cooking surfaces.
- To avoid overheating, **DO NOT** install the cooker behind a decorative door.
- **WARNING:** Accessible parts will become hot during use and will retain heat even after you have stopped cooking. Keep babies and children away from the cooker and never wear loose-fitting or hanging clothes when using the appliance.
- **DO NOT** use a steam cleaner on your cooker.
- Always keep combustible materials, e.g. curtains, and flammable liquids a safe distance away from the cooker.
- **DO NOT** spray aerosols in the vicinity of the cooker while it is on.

## Electrical Connection Safety

**⚠ WARNING: THE APPLIANCE MUST BE EARTHED.**

**Note:** The cooker must be connected to the correct electrical supply as stated on the voltage label on the cooker, through a suitable cooker control unit incorporating a double-pole switch, having a contact separation of at least 3 mm in all poles.

**⚠ The cooker MUST NOT be connected to an ordinary domestic power point.**

**Fig. 1.1**

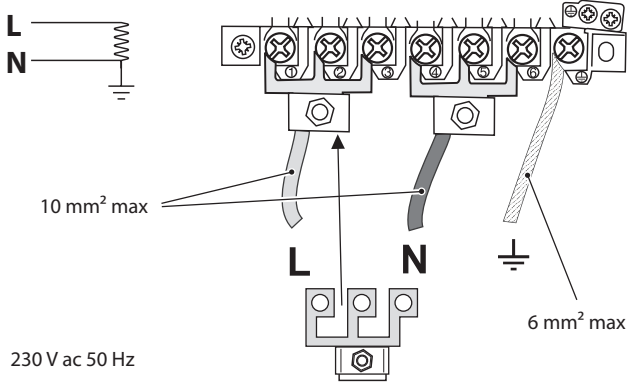

Access to the mains terminal is gained by removing the electrical terminal cover box on the back panel. Connect the mains cable to the correct terminals for your electrical supply type (**Fig. 1.1** and **Fig. 1.2**). Check that the links are correctly fitted and that the terminal screws are tight. Secure the mains cable using the cable clamp.

Minimum temperature rating T105.

Read the instructions before installing or using this appliance.

**Fig. 1.2**

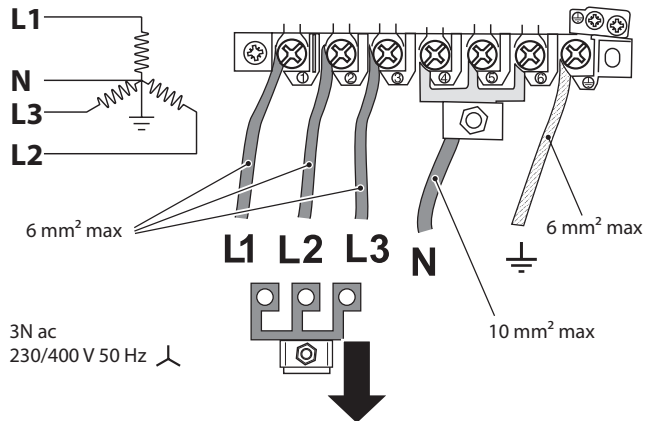

## Gas Connection Safety

- This cooker is a Class 2 Subclass 1 appliance.
- This appliance can be converted for use on another gas.
- Before installation, make sure that the cooker is suitable for your gas type and supply voltage. See the data badge.
- DO NOT use reconditioned or unauthorised gas controls.
- Disconnect from the electricity and gas supply before servicing.
- When servicing or replacing gas-carrying components disconnect from the gas supply before starting operation. Check the appliance is gas sound after completion.
- Make sure that the gas supply is turned on and that the cooker is wired in and switched on.
- In your own interest and that of safety, it is law that all gas appliances be installed by a qualified person(s).
- An appliance for use on LPG must not be installed in a room or internal space below ground level, e.g. in a basement.



## If You Smell Gas

- **DO NOT** turn electric switches on or off
- **DO NOT** smoke
- **DO NOT** use naked flames
- Turn off the gas at the meter or cylinder
- Open doors and windows to get rid of the gas
- Keep people away from the area affected
- Call your gas supplier

## Peculiar Smells

When you first use your cooker it may give off an odour. This should stop after use.

Before using for the first time, make sure that all packing materials have been removed and then, to dispel manufacturing odours, turn the ovens to 200 °C and run for at least an hour.

Before using the grill for the first time you should also turn on the grill and run for 30 minutes with the grill pan in position, pushed fully back and the grill door open.

Make sure the room is well ventilated to the outside air (see 'Ventilation' below). People with respiratory or allergy problems should vacate the area for this brief period.

## Cooling Fan

This appliance may have a cooling fan. When the grill or ovens are in operation the fan will run to cool the fascia and control knobs.

## Ventilation

The use of a cooking appliance results in the production of heat and moisture in the room in which it is installed. Therefore, make sure that the kitchen is well ventilated: keep natural ventilation holes open or install a powered cookerhood that vents outside. If you have several hotplates/burners on, or use the cooker for a long time, open a window or turn on an extractor fan

## Maintenance

- It is recommended that this appliance is serviced annually.
- **WARNING:** Before replacing the bulb, turn off the power supply and make sure that the oven is cool.
- **DO NOT** use cooking vessels on the hotplate that overlap the edges.
- Unless specified otherwise in this guide, always allow the cooker to cool and then switch it off at the mains before cleaning or carrying out any maintenance work.
- **DO NOT** use the control knobs to manoeuvre the cooker.
- **NEVER** operate the cooker with wet hands.
- **DO NOT** use a towel or other bulky cloth in place of a glove – it might catch fire if brought into contact with a hot surface.
- **DO NOT** use hotplate protectors, foil or hotplate covers of any description. These may affect the safe use of your hotplate burners and are potentially hazardous to health.
- **NEVER** heat unopened food containers. Pressure build up may make the containers burst and cause injury.
- **WARNING:** Use only hob guards designed by the manufacturer of the cooking appliance or indicated by the manufacturer of the appliance in the instructions for use as suitable or hob guards incorporated in the appliance. The use of inappropriate guards can cause accidents.
- **DO NOT** use unstable saucepans. Always make sure that you position the handles away from the edge of the hotplate.
- **NEVER** leave the hotplate unattended at high heat settings. Pans boiling over can cause smoking, and greasy spills may catch on fire. Use a deep fat thermometer

whenever possible to prevent fat overheating beyond the smoking point.

**⚠ WARNING: Unattended cooking on a hob with fat or oil can be dangerous and may result in fire.**

**⚠ NEVER** try to extinguish a fire with water, but switch off the appliance and then cover the flame e.g. with a lid or a fire blanket.

- **NEVER** leave a chip pan unattended. Always heat fat slowly, and watch as it heats. Deep fry pans should be only one third full of fat.
- **WARNING: Danger of fire: do not store items on the cooking surfaces.**
- **NEVER** try to move a pan of hot fat, especially a deep fat fryer. Wait until the fat is cool. Filling the pan too full of fat can cause spill over when food is added. If you use a combination of oils or fats in frying, stir them together before heating, or as the fats melt.
- Foods for frying should be as dry as possible. Frost on frozen foods or moisture on fresh foods can cause hot fat to bubble up and over the sides of the pan. Carefully watch for spills or overheating of foods when frying at high or medium high temperatures.
- **DO NOT** use the top of the flue (the slot along the back of the cooker) for warming plates, dishes, drying tea towels or softening butter.
- **DO NOT** use water on grease fires and never pick up a flaming pan. Turn the controls off and then smother a flaming pan on a surface unit by covering the pan completely with a well fitting lid or baking tray. If available, use a multi-purpose dry chemical or foam-type fire extinguisher.
- **DO NOT** modify this appliance. This appliance is not intended to be operated by means of external timer or separated remote-control system.

- If flammable materials are stored in the drawer, oven(s) or grill(s) it may explode and result in fire or property damage.

## Oven Care

- When the oven is not in use and before attempting to clean the cooker always be certain that the control knobs are in the **OFF** position.
- Use oven gloves to protect your hand from potential burns.
- Cooking high moisture content foods can create a 'steam burst' when the oven door is opened (**Fig. 1.3**). When opening the oven, stand well back and allow any steam to disperse.
- The inside door face is constructed with toughened safety glass. Take care **NOT** to scratch the surface when cleaning the glass panel.
- Accidental damage may cause the door glass panel to fracture.
- Keep oven vent ducts unobstructed.
- **DO NOT** use harsh abrasive cleaners or sharp metal scrapers to clean the oven door glass since they can scratch the surface, which may result in shattering of the glass.
- Make sure the shelves are pushed firmly to the back of the oven. **DO NOT** close the door against the oven shelves.
- **DO NOT** use aluminium foil to cover shelves, linings or the oven roof.
- When the oven is on, **DO NOT** leave the oven door open for longer than necessary, otherwise the control knobs may become very hot.
- **DO NOT** use the timed oven if the adjoining oven is already warm.
- **DO NOT** place warm food in the oven to be timed.



- **DO NOT** use a timed oven that is already warm.
- Use dry oven gloves when applicable – using damp gloves might result in steam burns when you touch a hot surface.

### Oven Shelves (depending on model)

To fit the glide-out shelf, hook the front of the shelf onto the runners as shown (Fig. 1.4). The rear of the shelf should rest on the runners, in front of the rear stop (Fig. 1.4).

Standard oven shelves can be fitted by lining up the shelf with a groove in the oven ladders. Push the shelf back until the ends hit the shelf stop. Lift the front so the shelf clears the stops, then lower the front so the shelf is level and push it fully back.

### Grill/Glide-out Grill™ Care

**⚠ WARNING: Unattended cooking under the grill can be dangerous and may result in fire.**

- When using the grill, make sure that the grill pan is in position and pushed fully in, otherwise the control knobs may become very hot.
- **DO NOT** leave the grill on for more than a few moments without the grill pan underneath it, otherwise the knobs may become hot.
- **NEVER** close the grill door when the grill is on.
- Accessible parts may be hot when the grill is in use. Young children should be kept away

### Cooker Care

As steam can condense to water droplets on the cool outer trim of the oven, it may be necessary during cooking to wipe away any moisture with a soft cloth. This will also help to prevent soiling and discolouration of the oven exterior by cooking vapours.

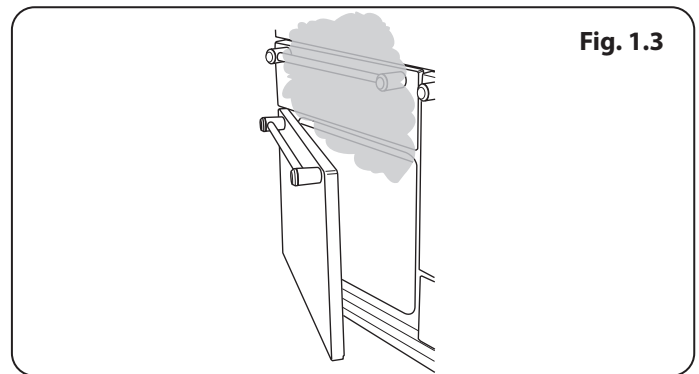

Fig. 1.3

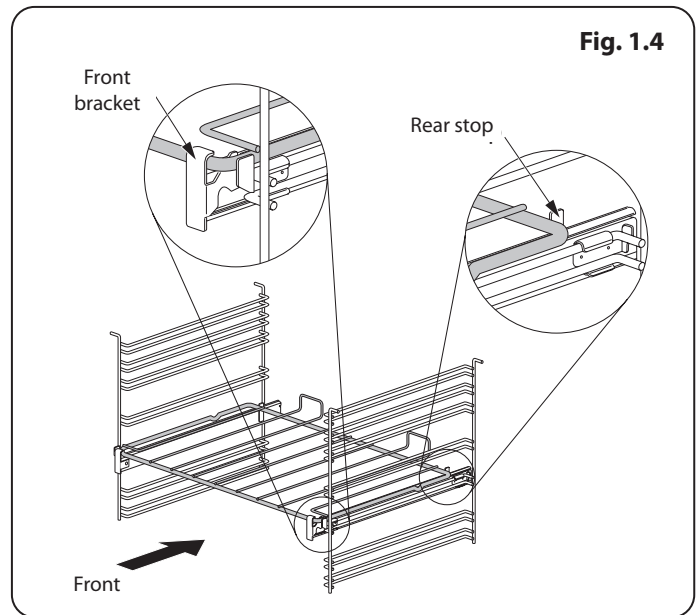

Fig. 1.4

## Cleaning

- Isolate the electricity supply before carrying out any thorough cleaning. Allow the cooker to cool.
- In the interests of hygiene and safety, the cooker should be kept clean at all times as a build up in fats and other food stuff could result in a fire.
- Clean only the parts listed in this guide.
- Clean with caution. If a wet sponge or cloth is used to wipe spills on a hot surface, be careful to avoid steam burns. Some cleaners can produce noxious fumes if applied to a hot surface.
- **NEVER** use paint solvents, washing soda, caustic cleaners, biological powders, bleach, chlorine based bleach cleaners, coarse abrasives or salt.
- **DO NOT** mix different cleaning products – they may react together with hazardous results.
- All parts of the cooker can be cleaned with hot soapy water.
- Take care that no water seeps into the appliance.
- Before you remove any of the grill parts for cleaning, make sure that they are cool or use oven gloves.
- **DO NOT** use any abrasive substances on the grill and grill parts.
- **DO NOT** put the side runners in a dishwasher.
- **DO NOT** put the burner heads in a dishwasher.
- **NEVER** use caustic or abrasive cleaners as these will damage the surface.
- **DO NOT** use steel wool, oven cleaning pads or any other materials that will scratch the surface.
- **NEVER** store flammable materials in the drawer. This includes paper, plastic and cloth items, such as cookbooks, plastic ware and towels, as well as flammable liquids.
- **DO NOT** store explosives, such as aerosol cans, on or near the appliance.
- **DO NOT** use steel wool, oven cleaning pads, or any other materials that will scratch the surface.
- **DO NOT** attempt to disassemble or clean around any burner while another burner is on, otherwise an electric shock could result.

## 2. Cooker overview



The 1092 dual fuel cooker (**Fig. 2.1**) has the following features:

- A. 5 hotplate burners
- B. A control panel
- C. Multi-function oven
- D. Fan oven
- E. Storage drawer

### Hotplate burners

The drawing by each of the central knobs indicates which burner that knob controls.

Each burner has a Flame Supervision Device (FSD) that prevents the flow of gas if the flame goes out.

**When a hotplate control knob is pressed in, sparks will be made at every burner: this is normal. DO NOT attempt to disassemble or clean around any burner while another burner is on, otherwise an electric shock could result.**

To light a burner, push in the selected burner control knob and turn it to the high position, as indicated by the large flame symbol (🔥) (**Fig. 2.2**).

The igniter should spark and light the gas. Keep holding the knob pressed in to let the gas through to the burner for about ten seconds.

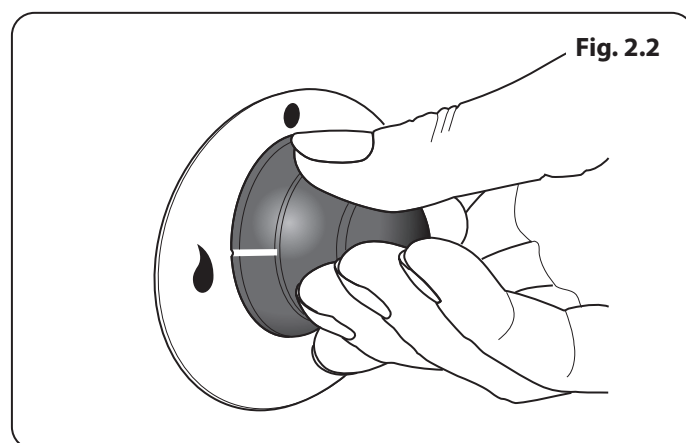

# English

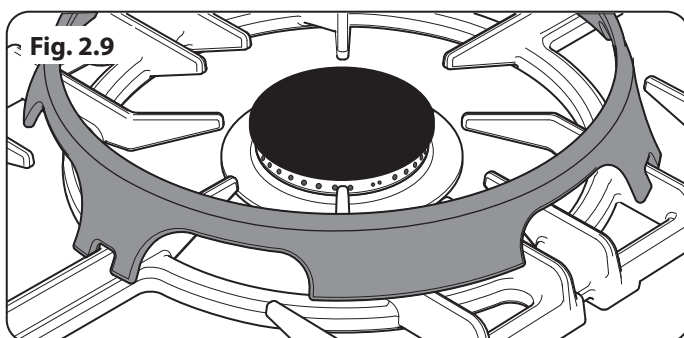
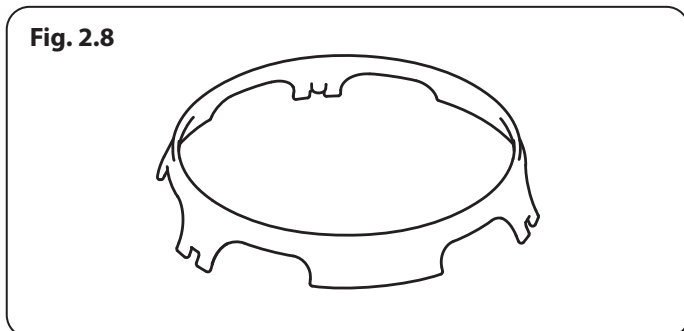
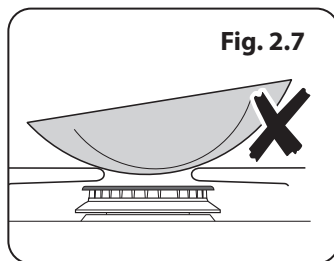
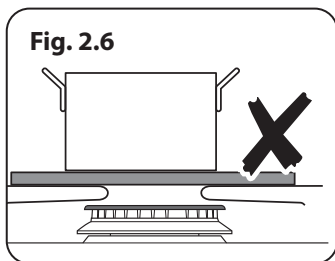
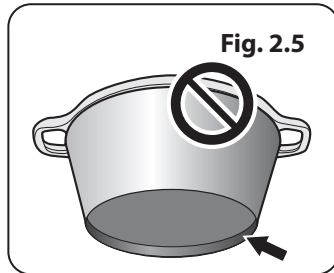
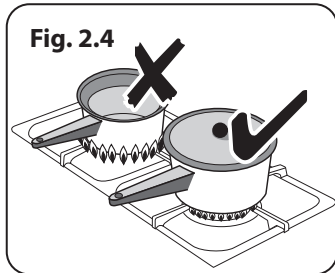
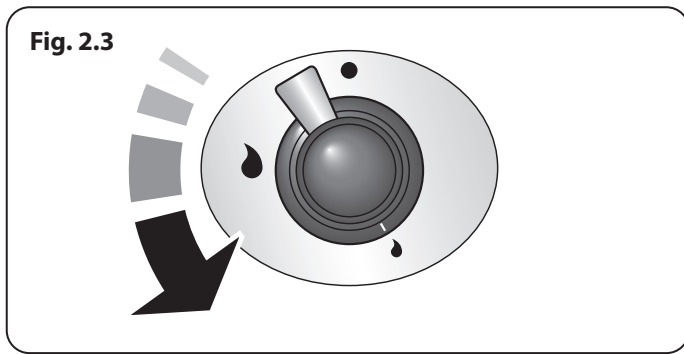

If, when you let go of the control knob the burner goes out, then the FSD has not been bypassed. Turn the control knob to the OFF position and wait for one minute before you try again, this time making sure to hold in the control knob for slightly longer.

Adjust the flame height to suit by turning the knob counter-clockwise (**Fig. 2.3**). On this cooker the low position is beyond high, **NOT** between high and off.

If a burner flame goes out, turn off the control knob and leave it for one minute before relighting it.

Make sure that the flames are under the pans. Using a lid will help the contents boil more quickly (**Fig. 2.4**).

Large pans should be spaced well apart.

Pans and kettles with concave bases or down-turned base rims should not be used (**Fig. 2.5**).

Simmering aids, such as asbestos or mesh mats, are **NOT** recommended (**Fig. 2.6**). They will reduce burner performance and could damage the pan supports.

You should also avoid using unstable and misshapen pans that may tilt easily, and pans with a very small base diameter, e.g. milk pans, single egg poachers (**Fig. 2.7**).

The minimum recommended pan diameter is 160 mm. The maximum allowable pan base diameter is 260 mm.

**DO NOT** use cooking vessels on the hotplate that overlap the edges.

**Note:** Use of aluminium pans may cause metallic marking of the pan supports. This does not affect the durability of the enamel and may be cleaned off with a proprietary metal cleaner.

## Wok cradle

The wok cradle is designed to fit the centre burner (**Fig. 2.8**). It will not fit any of the other burner pan supports.

It should be located so that the cut-outs in the cradle sit directly on the projecting burner supports (**Fig. 2.9**).

Woks vary very widely in size and shape. It is important that the wok is securely held: if the wok is too big or too small the cradle will not support it properly.

For the wok to heat properly it must be close to the burner. For this reason we recommend that you do not use the wok cradle with a flat bottomed wok.

When you fit the cradle, check that it is properly located on the pan support fingers. Make sure that it is stable and that the wok is sitting level in the cradle.

**⚠ The wok cradle will get very hot in use – allow plenty of time for it to cool before you pick it up.**

## The ovens

References to 'left-hand' and 'right-hand' ovens apply as viewed from the front of the appliance.

The left-hand oven is a multi-function oven, while the right-hand oven is a fan oven.

### The left-hand multi-function oven

As well as the oven fan and fan element, they are fitted with two extra heating elements, one visible in the top of the oven and the second under the oven base. Take care to avoid touching the top element and element deflector when placing or removing items from the ovens.

The multi-function oven has 3 main cooking functions: **fan**, **fan assisted** and **conventional cooking**. These functions should be used to complete most of your cooking.

The **browning element** and **base heat** can be used in the latter part of the cooking process to fine tune the results to your particular requirements.

Use **fanned grilling** for all your grilling needs and **defrost** to safely thaw small items of frozen food.

**Table 2.1** gives a summary of the multi-function modes.

The multi-function ovens have many varied uses. We suggest you keep a careful eye on your cooking until you are familiar with each function. Remember: not all functions will be suitable for all food types.

Please remember that all cookers vary: temperatures in your new ovens may differ to those in your previous cooker.

Function	Use
<b>Defrost</b>	To thaw small items in the oven without heat
<b>Fan oven</b>	A full cooking function, even heat throughout, great for baking
<b>Fanned grilling</b>	Grilling meat and fish with the door closed
<b>Fan assisted</b>	A full cooking function good for roasting and baking
<b>Conventional oven</b>	A full cooking function for roasting and baking in the lower half of the oven
<b>Browning element</b>	To brown and crisp cheese topped dishes
<b>Base heat</b>	To crisp up the bases of quiche, pizza or pastry

**Table 2.1**

# English

## Multi-function Oven Functions

### Defrost



This function operates the fan to circulate cold air only. Make sure the temperature control is at 0°C and that no heat is applied. This enables small items such as desserts, cream cakes and pieces of meat, fish and poultry to be defrosted.

Defrosting in this way speeds up the process and protects the food from flies. Pieces of meat, fish and poultry should be placed on a rack, over a tray to catch any drips. Be sure to wash the rack and tray after defrosting.

Defrost with the oven door closed.

Large items, such as whole chickens and joints should not be defrosted in this way. We recommend this be carried out in a refrigerator.

Defrosting should not be carried out in a warm oven or when an adjoining oven is in use or still warm.

Make sure that dairy foods, meat and poultry are completely defrosted before cooking.

### Fan oven



This function operates the fan and the heating element around it. An even heat is produced throughout the oven, allowing you to cook large amounts quickly.

Fan oven cooking is particularly suitable for baking on several shelves at one time and is a good 'all-round' function. It may be necessary to reduce the temperature by approximately 10°C for recipes previously cooked in a conventional oven.

If you wish to preheat the oven, wait until the indicator light has gone out before inserting the food.

### Fanned grilling



This function operates the fan whilst the top element is on. It produces a more even, less fierce heat than a conventional grill.

For best results, place the food to be grilled, on a grid over a roasting tin, which should be smaller than a conventional grill pan. This allows greater air circulation. Thick pieces of meat or fish are ideal for grilling in this way, as the circulated air reduces the fierceness of the heat from the grill.

The oven door should be kept closed while grilling is in progress, so saving energy.

You will also find that the food needs to be watched and turned less than for normal grilling. Preheat this function before cooking.

For best results we recommend that the grill pan is not located on the uppermost shelf.

### Fan assisted oven



This function operates the fan, circulating air heated by the elements at the top and the base of the oven. The combination of fan and conventional cooking (top and base heat) makes this function ideal for cooking large items that need thorough cooking, such as a large meat roast.

It is also possible to bake on two shelves at one time, although they will need to be swapped over during the cooking time, as the heat at the top of the oven is greater than at the base, when using this function.

This is a fast intensive form of cooking; keep an eye on the food cooking until you have become accustomed to this function.

### Conventional oven (Top and Base Heat)



This function combines the heat from the top and base elements. It is particularly suitable for roasting and baking pastry, cakes and biscuits.

Food cooked on the top shelf will brown and crisp faster than on the lower shelf, because the heat is greater at the top of the oven than at the base, as in 'Fan Assisted Oven' function. Similar items being cooked will need to be swapped around for even cooking. This means that foods requiring different temperatures can be cooked together, using the cooler zone in the lower half of the oven and hotter area to the top.

The exposed top element may cook some foods too quickly, so we recommend that the food be positioned in the lower half of the oven to cook. The oven temperature may also need to be lowered.

### Browning element



This function uses the element in the top of the oven only. It is a useful function for the browning or finishing of pasta dishes, vegetables in sauce, shepherds pie and lasagne, the item to be browned being already hot before switching to the top element.

### Base heat



This function uses the base element only. It will crisp up your pizza or quiche base or finish off cooking the base of a pastry case on a lower shelf. It is also a gentle heat, good for slow cooking of casseroles in the middle of the oven or for plate warming.

The Browning and Base Heat functions are useful additions to your oven, giving you flexibility to finish off items to perfection.



## Right-hand fan oven

The right-hand oven is a fan oven that circulates hot air continuously, which means faster, more even cooking.

The recommended cooking temperatures for a fan oven are generally lower than a conventional oven.

**Note:** Please remember that all cookers vary so temperatures in your new ovens may differ to those in your previous cooker.

## Operating the ovens

### Operating the multi-function oven

The multi-function oven has two controls: a function selector and a temperature setting knob (Fig. 2.10).

Turn the function selector control to a cooking function. Fig. 2.11 shows the control set for convectional oven cooking.

Turn the oven temperature knob to the temperature required (Fig. 2.12).

The oven indicator light will glow until the oven has reached the temperature selected (Fig. 2.13). It will then cycle on and off during cooking as the oven maintains the selected temperature.

### Operating the fan oven

Turn the oven knob to the desired temperature (Fig. 2.12).

The oven indicator light will glow until the oven has reached the temperature selected. It will then cycle on and off during cooking (Fig. 2.13).

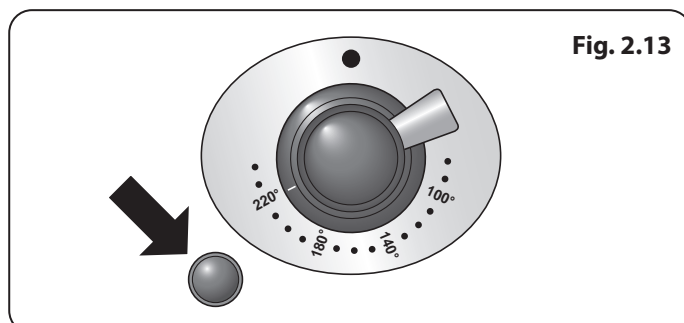
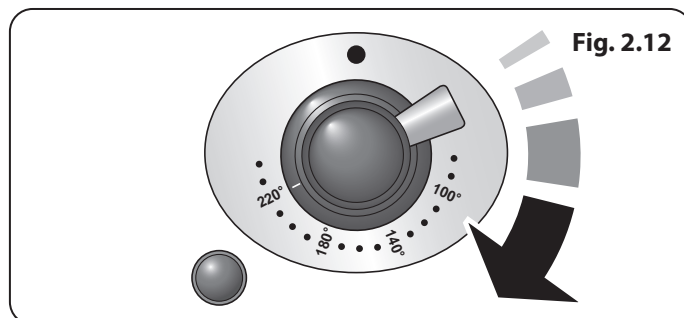
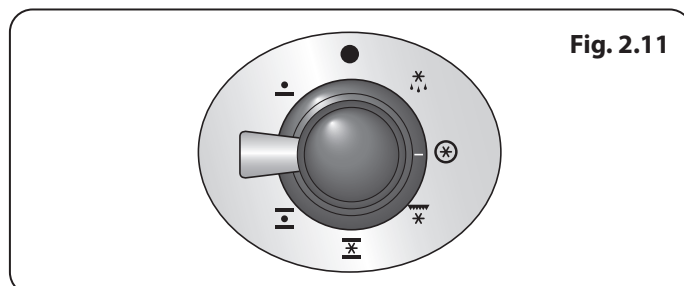
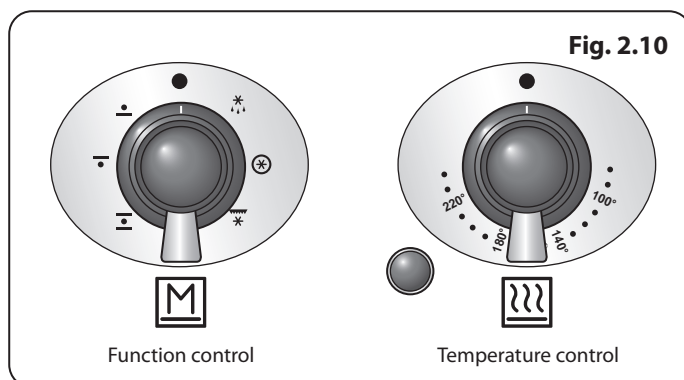

Fig. 2.14

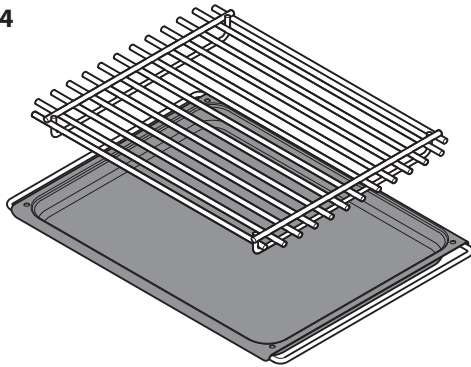

Fig. 2.15

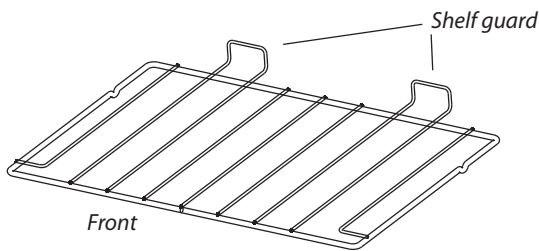

Fig. 2.16

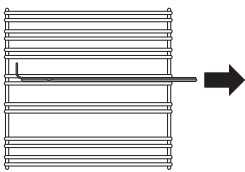

Fig. 2.17

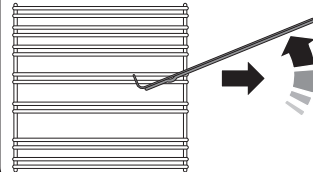

Fig. 2.18

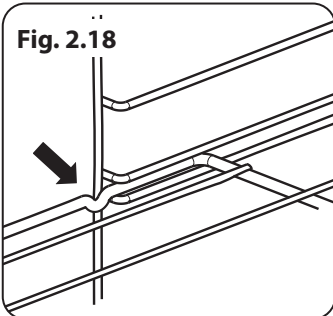
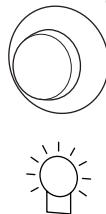

Fig. 2.19



## Accessories

### Oven shelves

The cooker is supplied with a deluxe oven tray (**Fig. 2.14**).

The deluxe oven tray has a trivet so that it can be used for grilling as well as normal oven cooking.

The cooker is supplied with 4 standard shelves (**Fig. 2.15**).

The deluxe tray slides in and out easily: take care when pulling it forward that it does not become unstable or slide out of the grooves in the side of the oven.

The oven shelves are retained when pulled forward but can be easily removed and refitted.

Pull the shelf forward until the back of the shelf is stopped by the shelf stop bumps in the oven sides (**Fig. 2.16**).

Lift up the front of the shelf so the back of the shelf will pass under the shelf stop and then pull the shelf forwards (**Fig. 2.17**).

To refit the shelf, line up the shelf with a groove in the oven side and push the shelf back until the ends hit the shelf stop (**Fig. 2.18**). Lift up the front so the shelf ends clear the shelf stops, and then lower the front so that the shelf is level and push it fully back.

### Oven Lights

Press the button to turn on the oven lights (**Fig. 2.19**).

If the oven light fails, turn off the power supply before changing the bulb. See the 'Troubleshooting' section for details on how to change the bulb.

### Storage

The bottom drawer is for storing oven trays and other cooking utensils.

It can get very warm, so do not store anything in it, which may melt or catch fire.

**⚠ Never store flammable materials in the drawer. This includes paper, plastic and cloth items, such as cookbooks, plastic ware and towels, as well as flammable liquids.**

**⚠ DO NOT store explosives, such as aerosol cans, on or near the appliance.**

## 3. Cooking tips

---

### Cooking with a multifunction oven

Remember: not all modes are suitable for all food types. The oven cooking times given are intended for a guide only.

### General oven tips

The wire shelves should always be pushed firmly to the back of the oven.

Baking trays with food cooking on them should be placed level with the front edge of the oven's wire shelves. Other containers should be placed centrally.

Keep all trays and containers away from the back of the oven, as overbrowning of the food may occur.

For even browning, the maximum recommended size of a baking tray is:

- depth: 340 mm (13 3/8") by width: 340 mm (13 3/8")

**When the oven is on, do not leave the door open for longer than necessary, otherwise the knobs may get very hot.**

- Always leave a "finger's width" between dishes on the same shelf. This allows the heat to circulate freely around them.
- To help keep your oven clean, cover meat when roasting, with foil or use a roasting bag.
- To reduce fat splashing when you add vegetables to hot fat around a roast, dry them thoroughly or brush lightly with cooking oil.
- Where dishes may boil and spill over during cooking, place them on a baking tray.
- If you want to brown the base of a pastry dish, preheat the baking tray for 15 minutes before placing the dish in the centre of the tray.

## 4. Cooking Table

The oven control settings and cooking times given in the table below are intended to be used **as a guide only**. Individual tastes may require the temperature to be altered to provide a preferred result.

Food is cooked at lower temperature in a fan oven than in a conventional oven. When using recipes, reduce the fan oven temperature by 10°C and the cooking time by 5-10 minutes. The temperature in the fan oven does not vary with height in the oven so you can use any shelf.

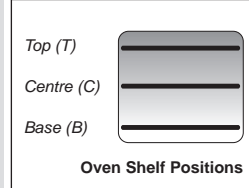

Food	Conventional Oven °C (Shelf Position)	Fan Oven Temperature	Approximate Cooking Time		
<b>Meat</b>					
Beef (no bone)	160 (C)	150 °C	30-35 minutes per 500g +30-35 minutes.	Thoroughly thaw frozen joints before cooking. Meat may be roasted at 220°C (210°C for fan oven) and the cooking time adjusted accordingly. For stuffed and rolled meats, add approximately 10 minutes per 500g, or cook at 200°C (190°C) for 20 minutes then 160°C (150°C) for the remainder.	
	200 (C)	190 °C	20-25 minutes per 500g +20-25 minutes.		
Lamb	160 (C)	150 °C	30-35 minutes per 500g +30-35 minutes.		
	200 (C)	190 °C	25-30 minutes per 500g +25-30 minutes.		
Pork	160 (C)	150 °C	35-40 minutes per 500g +35-40 minutes.		
	200 (C)	190 °C	25-30 minutes per 500g +25-30 minutes.		
<b>Poultry</b>					
Chicken	160 (C)	150 °C	20-25 minutes per 500g +20-25 minutes.		For stuffed poultry, you could cook at 200°C (190°C) for 20 minutes then 160°C (150°C) for remainder. Do not forget to include the weight of the stuffing. For fresh or frozen pre-packed poultry, follow instructions on the pack. Thoroughly thaw frozen poultry before cooking.
	200 (C)	190 °C	15-20 minutes per 500g +15-20 minutes.		
Turkey	160 (C)	150 °C	20 minutes per 500g +20 minutes.		
	200 (C)	190 °C	15 minutes per 500g +15 minutes.		
Duck	160 (C)	150 °C	25-30 minutes per 500g.		
	200 (C)	190 °C	20 minutes per 500g.		
<b>Casserole</b>	140-150 (C)	130 °C-140 °C	2-4 hours according to recipe.		
<b>Yorkshire Pudding</b>	220 (C)	210 °C	Large tins 30-35 minutes; individual 10-20 minutes.		
<b>Cake</b>					
Very rich fruit - Christmas, wedding, etc.	140 (C/B)	130 °C	45-50 minutes per 500g of mixture.	Using the conventional oven: When two tier cooking leave at least one runner space between shelves. Position the baking tray with the front edge along the front of the oven shelf.  Up to three tiers can be cooked on, in a fan oven, at the same time. But make sure to leave at least one runner space between each shelf being cooked on.	
Fruit 180 mm tin	150 (C/B)	140 °C	2-2½ hours.		
Fruit 230 mm tin	150 (C/B)	140 °C	Up to 3½ hours.		
Madeira 180 mm	160 (C/B)	150 °C	80-90 minutes.		
Queen cakes	190 (C/B)	180 °C	15-25 minutes.		
Scones	220 (C/B)	210 °C	10-15 minutes.		
Victoria sandwich					
180 mm tin	180 (C/B)	170 °C	20-30 minutes.		
210 mm tin	180 (C/B)	170 °C	30-40 minutes.		
<b>Desserts</b>					
Shortcrust tarts	200 (C/B)	190 °C	20-30 minutes on a preheated tray.	Up to three tiers can be cooked on, in a fan oven, at the same time. But make sure to leave at least one runner space between each shelf being cooked on.	
Fruit pies	200 (C/B)	190 °C	35-45 minutes.		
Tartlets	200 (C/B)	190 °C	10-20 minutes according to size.		
Puff pastry	210 (C/B)	200 °C	20-40 minutes according to size.		
Meringues	100 (C/B)	90 °C	2-3 hours.		
Baked egg custard	160 (C/B)	150 °C	45-60 minutes.		
Baked sponge pudding	180 (C/B)	170 °C	40-45 minutes.		
Milk pudding	140-150 (C/B)	130 °C-140 °C	2 to 3 hours.		
<b>Bread</b>	210 (C)	200 °C	20-30 minutes.		
<b>Fish</b>					
Fanned Grilling					
Fillet	190 (C/B)	190 °C (C/B)	15-20 minutes		
Whole	190 (C/B)	190 °C (C/B)	15-20 minutes per 500g.		
Steak	190 (C/B)	190 °C (C/B)	Steaks according to thickness.		

## 5. Cleaning your cooker

### Essential Information

Isolate the electricity supply before carrying out any thorough cleaning. Allow the cooker to cool.

**⚠ Never use paint solvents, washing soda, caustic cleaners, biological powders, bleach, chlorine based bleach cleaners, coarse abrasives or salt.**

**⚠ Do not mix different cleaning products: they may react together with hazardous results.**

All parts of the cooker can be cleaned with hot soapy water – **but take care that no surplus water seeps into the appliance.**

Remember to switch on the electricity supply before re-using the cooker.

#### Daily care

Cleaning the cooker is not a welcomed chore, but it has to be done to maintain efficiency and appearance. Remember it is better to wipe up any spills as they occur, this will prevent them burning on and becoming more difficult to remove later.

**⚠ Make sure the flow of combustion and ventilation air to the cooker is unobstructed: for example by build-up of fats or grease.**

#### Cleaning for spills

For spills and boil-overs that occur while cooking, as soon as possible turn off the burner and allow to cool. **DO NOT** clean until the area is completely cooled down. Wipe up spills as soon as possible.

**DO NOT** allow surplus water to seep into the cooker.

#### Cooktop burners

The burner heads and caps can be removed for cleaning. Make sure they are absolutely dry before replacing (**Fig. 5.1**).

When replacing a burner head, make sure that it locates properly within the base (**Fig. 5.2**). If you look at the bottom of the burner head you will see two 'pips': these fit into the two notches in the burner base (**Fig. 5.3**).

Check the burner ports are not blocked. If a blockage occurs, remove stubborn particles using a piece of fuse wire.

#### The wok cradle

Recommended cleaning materials are hot soapy water, a moistened soap pad, cream cleaner or a nylon scourer.

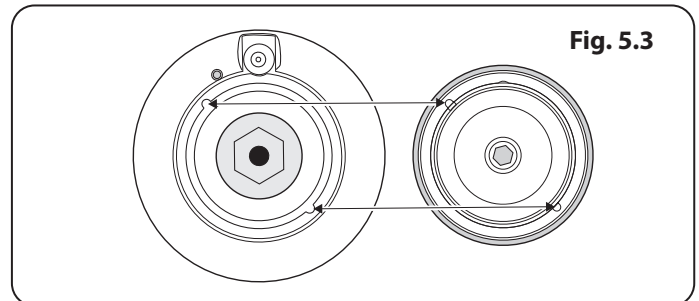
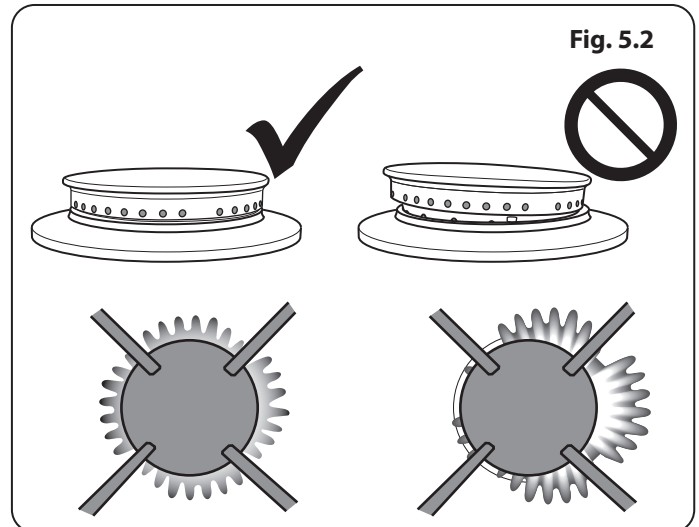
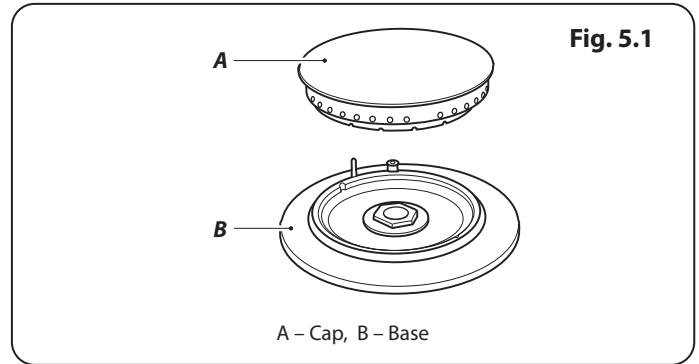
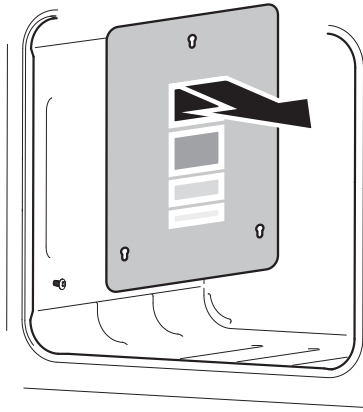

Fig. 5.4



## Main top

Lift away pots or pans from the main top. Remove the pan supports from the spillage area and carefully place in a sink of warm soapy water.

Wipe loose debris from main top. Avoid using any abrasive cleaners including cream cleaners. For best results use a liquid detergent cleaner. Rinse with cold water and thoroughly dry with a clean, soft cloth. Make sure all parts are dry before repositioning.

**⚠ Never use caustic or abrasive cleaners as these will damage the surface.**

## Control panel and oven doors

The control panel and control knobs should only be cleaned with a soft cloth wrung out in clean hot soapy water but take care that no surplus water seeps into the appliance. Wipe with a clean dampened cloth then polish with a dry cloth.

The oven doors should only be cleaned with a soft cloth wrung out in clean hot soapy water.

## Ovens

Some of the lining panels can be removed for cleaning and for cleaning behind.

### Removing the oven linings

If you wish to clean the enamel interior of the oven, you will need to remove the shelves before removing the linings.

The side panels of either oven can be removed.

You do not have to remove the support brackets to remove the linings. Lift each lining upward and slide forward off the support brackets (**Fig. 5.4**).

Once the panels have been removed, the oven enamel interior can be cleaned.

**⚠ DO NOT use steel wool (or any other materials that will scratch the surface).**

**⚠ DO NOT use oven cleaning pads.**

Refit in the reverse order.



## Cleaning table

Cleaners listed (**Table 5.1**) are available from supermarkets or electrical retailers as stated.

For enamelled surfaces use a cleaner that is approved for use on vitreous enamel.

Regular cleaning is recommended. For easier cleaning, wipe up any spillages immediately.

<b>Hotplate</b>		
<b>Part</b>	<b>Finish</b>	<b>Recommended Cleaning Method</b>
Hob top	Enamel or stainless steel	Hot soapy water, soft cloth. Any stubborn stains remove gently with a nylon scourer.
Ceramic/induction hob	Toughened glass	Hot soapy water; cream cleaner/scourer if necessary.
Griddle plate (some models only)	Non-stick surface	Allow to cool. Wash in hot soapy water. Do not use abrasive cleaners/scourers. Dishwasher.
Warming zone (some models only)	Toughened glass	Hot soapy water, cream cleaner/scourer if necessary.
<b>Outside of Cooker</b>		
<b>Part</b>	<b>Finish</b>	<b>Recommended Cleaning Method</b>
Door, door surround and storage drawer exterior	Enamel or paint	Hot soapy water, soft cloth. Any stubborn stains, remove gently with a liquid detergent.
	Stainless steel	E-cloth or microfibre all-purpose cloth (supermarket).
Sides and plinth	Painted surface	Hot soapy water, soft cloth.
Splashback/rear grille	Enamel or stainless steel	Hot soapy water, soft cloth. Cream cleaner, with care, if necessary.
Control panel	Paint, enamel or stainless steel	Warm soapy water. Do not use abrasive cleaners on lettering.
Control knobs/handles & trims	Plastic/chrome, aluminium, copper or lacquered brass	Warm soapy water, soft cloth.
	Brass	Brass polish.
Oven door glass/glass lid	Toughened glass	Hot soapy water, cream cleaner/scourer if necessary.
<b>Oven</b>		
<b>Part</b>	<b>Finish</b>	<b>Recommended Cleaning Method</b>
Sides, floor & roof of oven NOT 'COOK & CLEAN' OVEN PANELS (see below)	Enamel	Any proprietary oven cleaner that is suitable for enamel. <b>CAUTION: CORROSIVE/CAUSTIC OVEN CLEANERS: FOLLOW MANUFACTURER'S INSTRUCTIONS.</b> Do not allow contact with the oven elements.
'Cook & Clean' oven panels (some models only)	Special enamel that partly cleans itself	This surface cleans itself at 200°C and above, or the panels can be removed and washed with hot soapy water and a nylon brush.
Oven shelves, Handyrack, grill trivet, Handygrill rack	Chrome	An oven interior cleaner that is suitable for chrome. Soap filled pad. Dishwasher.
Grill pan/meat tin (some models only)	Enamel	Hot soapy water. Soap filled pad. Dishwasher.

**Table 5.1**

## 6. Troubleshooting

---

### Hotplate/Cooktop ignition or hotplate burners faulty

Is the power on? If not, there maybe something wrong with the power supply.

Are the sparkers (ignition electrode) or burner slots blocked by debris?

Are the burner trim and caps correctly located? See the section on 'Cleaning'.

### Hotplate/Cooktop burners will not light

Make sure that the burner parts have been replaced correctly after wiping or removing for cleaning.

Check that there is not a problem with your gas supply. You can do this by making sure that other gas appliances you may have are working.

### Do the burners spark when you push the button?

If not, verify that the power is on.

### Steam is coming from the oven

When cooking foods with high water content (e.g. oven fries) there may be some steam visible at the rear grille.

Take care when opening the oven door, as there may be a momentary puff of steam when the oven door is opened. Stand well back and allow any steam to disperse.

### What cleaning materials are recommended for the cooker?

See the 'Cleaning' section for recommended cleaning materials.

**⚠ Never use caustic or abrasive cleaners as these will damage the surface.**

### An oven fan is noisy

The note of the oven fan may change as the oven heats up – this is perfectly normal.

### If there is an installation problem and I don't get my original installer to come back to fix it who pays?

You do. Service organizations will charge for their call outs if they are correcting work carried out by your original installer. It is in your interest to track down your original installer.

### Food is cooking too slowly, too quickly, or burning

Cooking times may differ from your previous oven.

Check that you are using the recommended temperatures and shelf positions – see the oven cooking guide. The oven control settings and cooking times are intended to be used only as a guide.

Individual tastes may require the temperature to be altered either way, to get the results you want.

### The oven is not cooking evenly

**DO NOT** use a baking tray with dimensions larger than those specified in the section on 'General Oven Tips'.

If you are cooking a large item, be prepared to turn it round during cooking.

If two shelves are used, check that space has been left for the heat to circulate. When a baking tray is put into the oven, make sure that it is placed centrally on the shelf.

Check that the door seal is not damaged and that the door catch is adjusted so that the door is held firmly against the seal.

A dish of water when placed on the shelf should be the same depth all over. (For example, if it is deeper at the back, then the back of the cooker should be raised up or the front lowered.) If the cooker is not level, arrange for your supplier to level it for you.

### Oven not coming on

Is the power on? If not, there may be something wrong with the power supply.

Is the cooker supply on at the isolator switch?

### Oven temperature getting hotter as the cooker gets older

If turning the temperature down using the oven control knob has not worked, or has only worked for a short time, then you may need a new thermostat. This should be fitted by a qualified service person.

### Oven light is not working

The bulb has probably burnt out. You can buy a replacement bulb (which is not covered under the warranty) from a good electrical shop. Ask for a 40W – 230V halogen lamp (G9) (**Fig. 6.1**).

Before removing the existing bulb, turn off the power supply and make sure that the oven and bulb have cooled. Open the oven door and remove the oven shelves.

Remove the bulb cover by turning it a quarter turn, counter-clockwise. It may be very stiff (**Fig. 6.2**).

Pull the existing bulb to remove it. When handling the replacement bulb, avoid touching the glass with your fingers, as oils from your hands can cause premature failure. Push, click in the replacement bulb.

Replace the bulb cover by turning it a quarter turn, clockwise. Turn on the circuit breaker and check that the bulb now lights.

### The oven door is misaligned

The bottom hinge of either oven door can be adjusted to alter the angle of the door (**Fig. 6.3**). Loosen the bottom hinge fixing screws and use the notch and a flat bladed screwdriver to move the position of the hinge to set the hinge position (**Fig. 6.4**).

Retighten the hinge screws.

### The fascia gets hot when I use the oven

The cooker is cooled by a fan. If the fascia becomes excessively hot when the cooker is in use then the cooling fan may have failed. Should this occur please contact your installer, a qualified repair engineer or Customer Service to arrange for its repair.

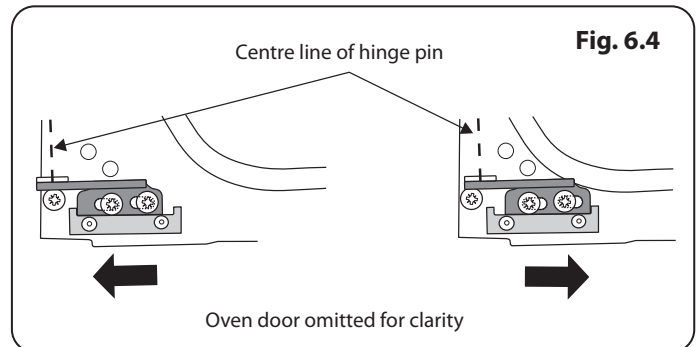
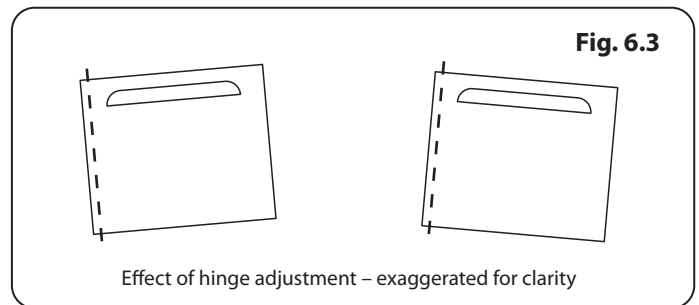
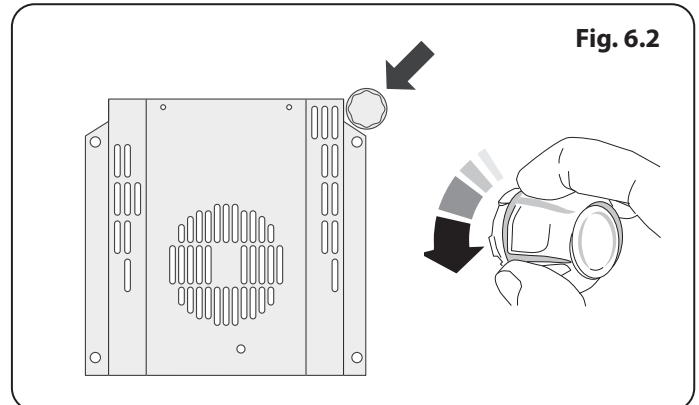
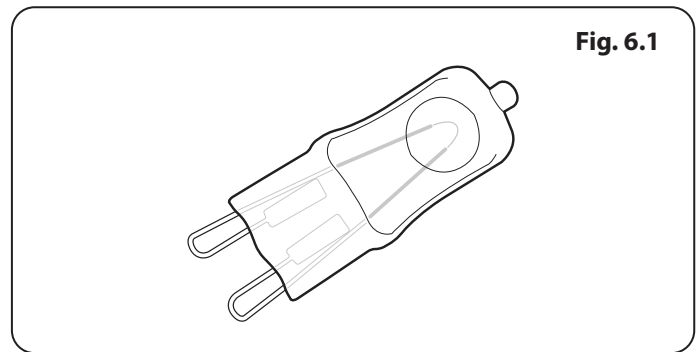

## INSTALLATION

Check the appliance is electrically safe and gas sound when you have finished.

# 7. Installation

## Dear installer

Before you start your installation, please complete the details below, so that, if your customer has a problem relating to your installation, they will be able to contact you easily.

<b>Installer's Name</b>
<b>Installer's Company</b>
<b>Installer's Telephone Number</b>
<b>Appliance Serial Number</b>

## Safety requirements and regulations

- ⚠ This cooker must be installed in accordance with the relevant instructions in this booklet, with the relevant national and local regulations, and with the local gas and electricity supply companies' requirements.**
- ⚠ If the appliance is to be installed in Switzerland, the following regulations and directives should be observed:**
  - SVGW - Gas principles G1: Gas installation.
  - EKAS - Form. 1942: Liquid gas directive, Part 2.
  - Cantonal instances regulations (e.g. fire safety regulators).
- ⚠ This cooker is a Class 2 Subclass 1 appliance.**
- ⚠ Before installation, make sure that the cooker is suitable for your gas type and supply voltage. See the data badge.**
- ⚠ The appliance must be installed in accordance with the regulations in force and only in a well ventilated space.**
- ⚠ Read the instructions before installing or using this appliance.**

**⚠ In your own interest and that of safety, it is law that all gas appliances be installed by competent persons. Failure to install the appliance correctly could invalidate any warranty or liability claims and lead to prosecution.**

**⚠ This appliance can be converted for use on another gas.**

## Provision of ventilation

This appliance is not connected to a combustion products evacuation device. Particular attention shall be given to the relevant requirements regarding ventilation.

All rooms require a window that can be opened, or equivalent, while some rooms require a permanent vent in addition to the window.

## Location of cooker

The cooker may be installed in a kitchen/kitchen diner but **NOT** in a room containing a bath or shower.

This appliance is designed for domestic cooking only. Use for any other purpose could invalidate any warranty or liability claim.

**Note:** An appliance for use on LPG must not be installed in a room or internal space below ground level, e.g. in a basement.

## Conversion

A conversion kit for another gas is available for the cooker.

If the appliance is to be converted to another gas we recommend that this is carried out before installation.

**⚠ We recommend an overpressure shut-off device or pressure relief valve be used in any LPG installation to prevent exposure of downstream fittings / appliances to excessive pressure (over 75mbar) in event of regulator failure.**

After converting the appliance, please attach the Gas Conversion sticker over the appropriate area of the data badge – this will identify the gas type for which the appliance is now set.

## INSTALLATION

Check the appliance is electrically safe and gas sound when you have finished.

### You will need the following equipment to complete the cooker installation satisfactorily:

- Stability bracket: If the cooker is to be supplied with gas through a flexible hose, a stability bracket or chain must be fitted.  
**These are not supplied with the cooker but are available at most builders' merchants.**
- Gas pressure tester/manometer.
- Flexible gas hose: Must be in accordance with the relevant standards.
- Multimeter: For electrical checks.

### You will also need the following tools:

1. Electric drill
2. Masonry drill bit (only required if fitting the cooker on a stone or concrete floor)
3. Wall plugs (only required if fitting the cooker on a stone or concrete floor)
4. Steel tape measure
5. Cross head screwdriver
6. Flat head screwdriver
7. Spirit level
8. Pencil
9. Adjustable spanner
10. Screws for fitting stability bracket
11. 4 mm & 3 mm Allen keys
12. 13 mm spanner or socket wrench

### Checking the parts:

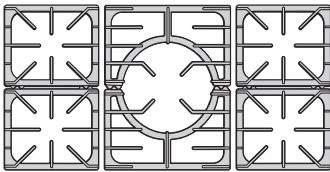
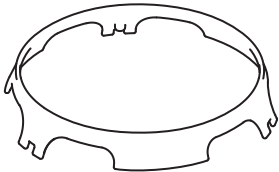
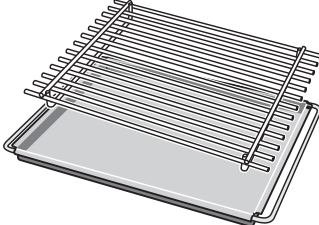
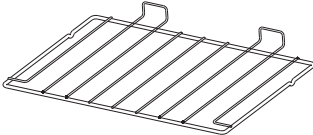
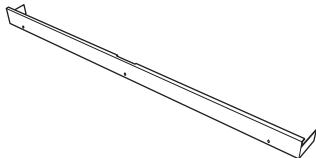
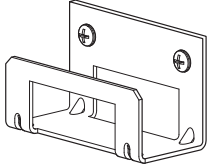
6 pan supports 	Wok cradle 
Deluxe grill tray & trivet 	4 flat shelves 
Plinth 	Stability location bracket 

## INSTALLATION

Check the appliance is electrically safe and gas sound when you have finished.

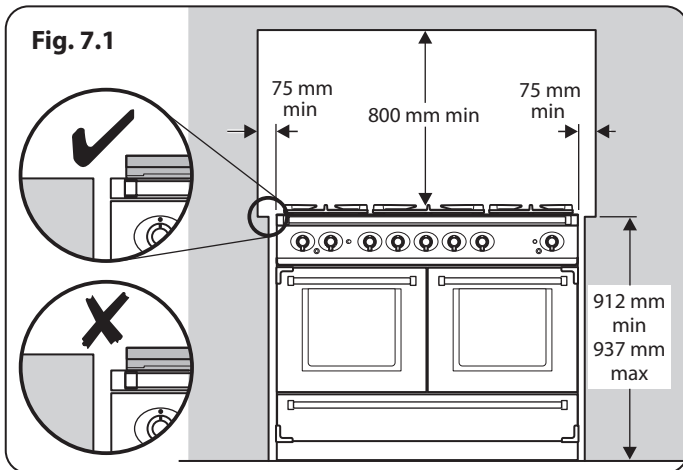

## Positioning the cooker

**Fig. 7.1** and **Fig. 7.2** shows the minimum recommended distance from the cooker to nearby surfaces.

The cooker should not be placed on a base.

Above hotplate surround should be level with, or above, any adjacent work surface.

A gap of 75 mm should be left between each side of the cooker **ABOVE** the hotplate level and any adjacent vertical surface.

For non-combustible surfaces (such as unpainted metal or ceramic tiles), this can be reduced to 25 mm.

A minimum space of 800 mm is required between the top of the hotplate and a horizontal combustible surface.

\*Any cookerhood should be installed in accordance with the hood manufacturer's instructions.

\*\*Any splashback must be fitted in accordance with the manufacturers instructions. Allowance should be made for the additional height of the flue trim, which is fitted to the cooker hob.

Surfaces of furniture and walls at the sides and rear of the appliance should be heat, splash and steam resistant. Certain types of vinyl or laminate kitchen furniture are particularly prone to heat damage and discolouration.

We cannot accept responsibility for damage caused by normal use of the cooker to any material that de-laminates or discolours at temperatures less than 65 °C above room temperature

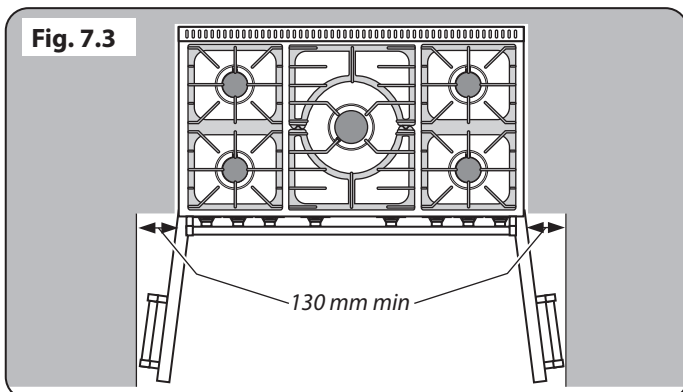
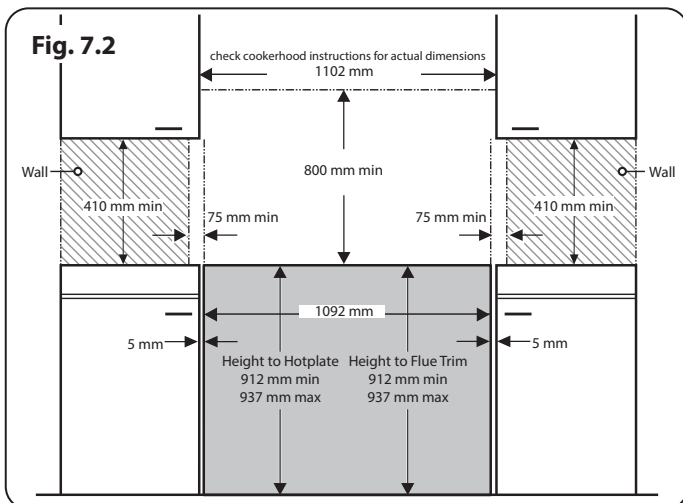

We recommend a gap of 1102 mm between units to allow for moving the cooker. **Do not** box the cooker in: it must be possible to move the cooker in and out for cleaning and servicing.

If the cooker is near a corner of the kitchen, a clearance of 130 mm is required to allow the oven doors to open (**Fig. 7.3**). The actual opening of the doors is slightly less but this allows for some protection of your hand as you open the door.

## Moving the cooker

**⚠ On no account try and move the cooker while it is plugged into the electricity supply.**

**⚠ The cooker is very heavy, so take great care.**

We recommend that two people manoeuvre the cooker. Make sure that the floor covering is firmly fixed, or removed, to prevent it being disturbed when moving the cooker around.

To help you, there are two levelling rollers at the back, and two screw-down levelling feet at the front.

Remove the polystyrene base pack. From the front, tilt the cooker backwards and remove the front half of the polystyrene base (**Fig. 7.4**).

Repeat from the back and remove the rear half of the polystyrene base.

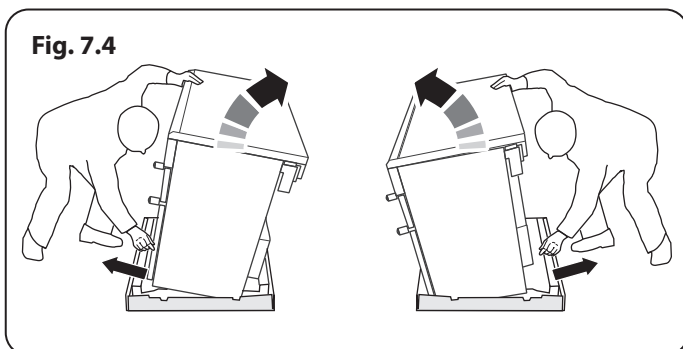



## INSTALLATION

Check the appliance is electrically safe and gas sound when you have finished.

### Lowering the two rear rollers

To adjust the height of the rear of the cooker, first fit a 13 mm spanner or socket wrench onto the hexagonal adjusting nut (**Fig. 7.5**). Rotate the nut – clockwise to raise – counter-clockwise to lower.

Make 10 complete (360°) turns clockwise.

Make sure you lower BOTH REAR ROLLERS.

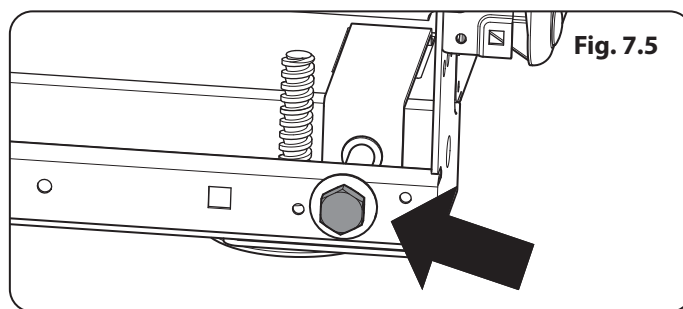

### Completing the move

Unfold the rear edge of the cardboard base tray. Open the oven doors so that you can get a good grip on the bottom of the fascia panel as you move the oven (**Fig. 7.6**).

Carefully push the cooker backwards off the base tray. Remove the base tray.

Position the cooker close to its final position, leaving just enough space to get behind it.

**⚠ Do not use the door handles or control knobs to manoeuvre the cooker.**

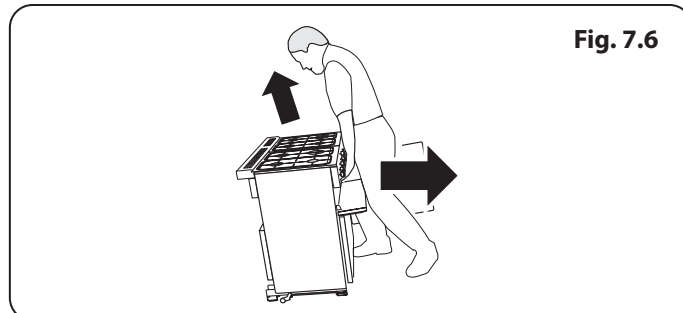

### Levelling

You are recommended to use a spirit level on a shelf in one of the ovens to check for level.

Place the cooker in its intended position taking care not to twist it within the gap between the kitchen units as damage may occur to the cooker or the units.

The front feet and rear rollers can be adjusted to level the cooker.

To adjust the height of the rear of the cooker use a 13 mm spanner or socket wrench to turn the adjusting nuts at the front bottom corners of the cooker.

To set the front turn the feet bases to raise or lower.

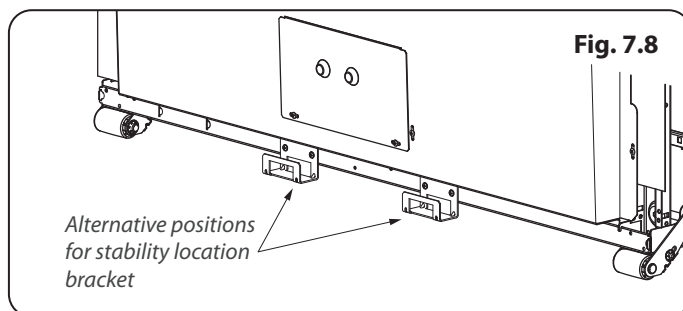
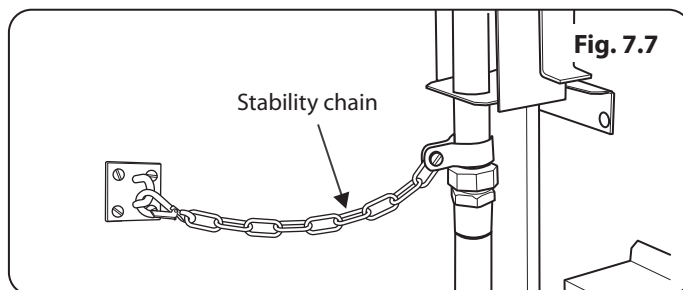

### Fitting a stability bracket or chain

Unless otherwise stated, a cooker using a flexible gas connector must be secured with a suitable stability device.

Suitable stability devices are shown in **Fig. 7.7** and **Fig. 7.8**.

If you are using a stability chain (**Fig. 7.7**) then the chain should be kept as short as is practicable and fixed firmly to the rear of the cooker.

If you are using a stability bracket; first attach the bracket location device to the rear of the cooker (**Fig. 7.8**). Then adjust the bracket to engage through the slot of the device (**Fig. 7.9** and **Fig. 7.10**).

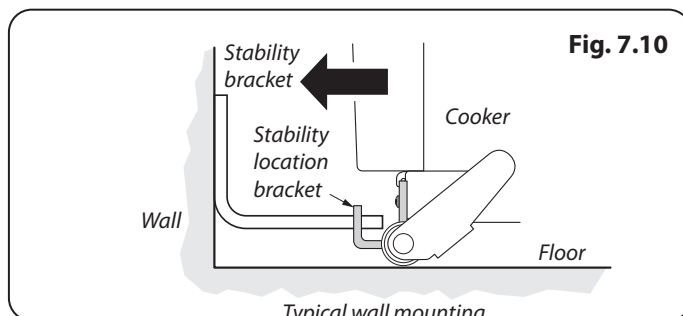
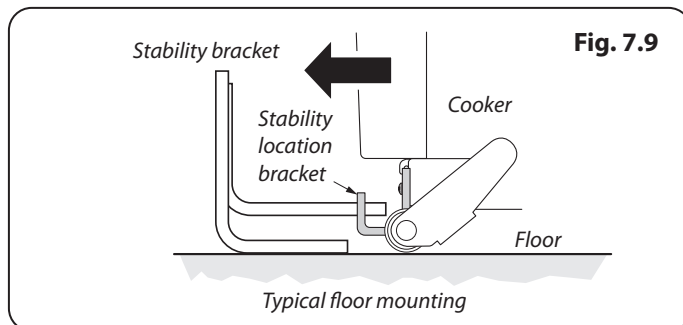

## INSTALLATION

Check the appliance is electrically safe and gas sound when you have finished.

**Fig. 7.11**

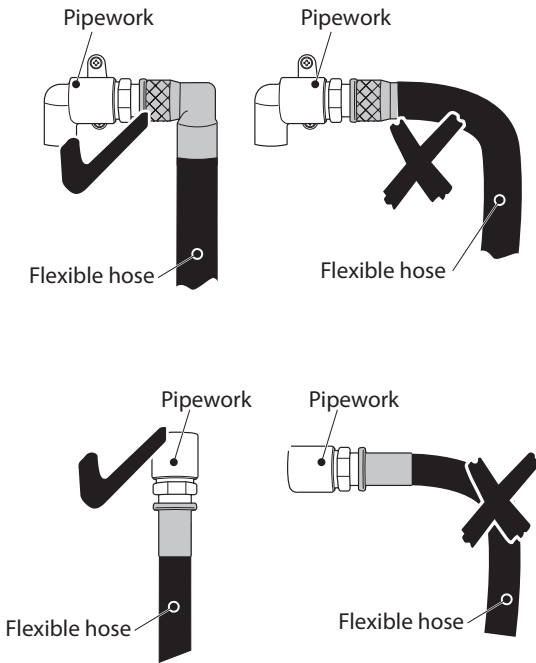

## Repositioning the cooker following connection

If you need to move the cooker once it has been connected then you need to unplug it and, having gripped under the fascia panel and lifted the front of the cooker slightly (**Fig. 7.6**), you need to check behind the cooker to make sure that the gas hose is not caught.

As you progress, make sure that both the electricity cable and gas hose always have sufficient slack to allow the cooker to move.

With a stability chain fitted, release it as you ease the cooker out. Do not forget to refit it when you replace the cooker.

When you replace the cooker, again check behind to make sure that the electricity cable and gas hose are not caught or trapped.

## Gas connection

This must be in accordance with the relevant standards.

The flexible hose (not supplied with the cooker) must be in accordance with the relevant standards. Hoses may be purchased at most builders' merchants.

The connector is located just below the hotplate level at the rear of the cooker. If in doubt contact your supplier.

The rear cover boxes limit the position of the supply point.

Because the height of the cooker can be adjusted and each connection is different, it is difficult to give precise dimensions.

Although a 900 mm hose can be used, a 1250 mm hose will allow slightly more flexibility in the positioning of the bayonet and make moving the cooker easier.

The hose should be fitted so that both inlet and outlet connections are vertical so that the hose hangs downwards in a 'U' shape.

Ideally the hose supply connection should be within the shaded area 'A' (**Fig. 7.12**).

For Natural Gas, the flexible hose must be in accordance with local codes and regulations. For LP Gas, it should be capable of 50 mbar pressure and 70 °C temperature rise. If in doubt contact your supplier.

Screw connect the threaded end of the hose into the gas inlet.

After completing the gas connection, make sure that the cooker is gas sound with a pressure test.

**Fig. 7.12**

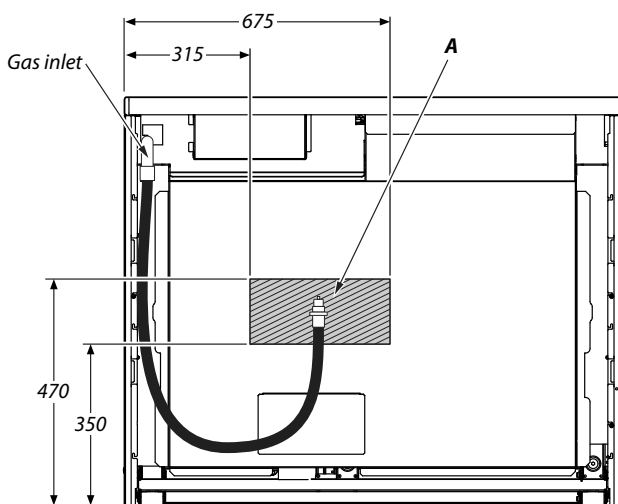

All dimensions in millimetres

## INSTALLATION

Check the appliance is electrically safe and gas sound when you have finished.

### Pressure testing

The gas pressure can be measured at the pressure test point on the gas connection block.

Connect the pressure gauge. Turn on and light one of the hotplate burners.

Turn on the control knob for the burner with the pressure gauge fitted to let gas through.

See the data badge for test pressures.

Turn off the burners. Make sure that you reassemble the burner top in the correct way on the burner body.

### Electrical connection

This appliance must be installed by a suitably qualified electrician to comply with the relevant electrical regulations, and also the local electricity supply company requirements.

**⚠ Warning: the appliance must be earthed.**

**Note:** The cooker must be connected to the correct electrical supply as stated on the voltage label on the cooker, through a suitable cooker control unit incorporating a double-pole switch, having a contact separation of at least 3 mm in all poles.

**⚠ The cooker must not be connected to an ordinary domestic power point.**

Access to the mains terminal is gained by removing the electrical terminal cover box on the back panel. Connect the mains cable to the correct terminals for your electrical supply type (**Fig. 7.13** and **Fig. 7.14**). Check that the links are correctly fitted and that the terminal screws are tight.

Secure the mains cable using the cable clamp.

#### Current Operated Earth Leakage Breakers

The combined use of your cooker and other domestic appliances may cause nuisance tripping, so we recommend that the cooker is protected on an individual RCD (Residual Current Device) or RCBO (Residual Current Breaker with Overload).

**IF IN DOUBT, PLEASE CONSULT A SUITABLY QUALIFIED ELECTRICIAN.**

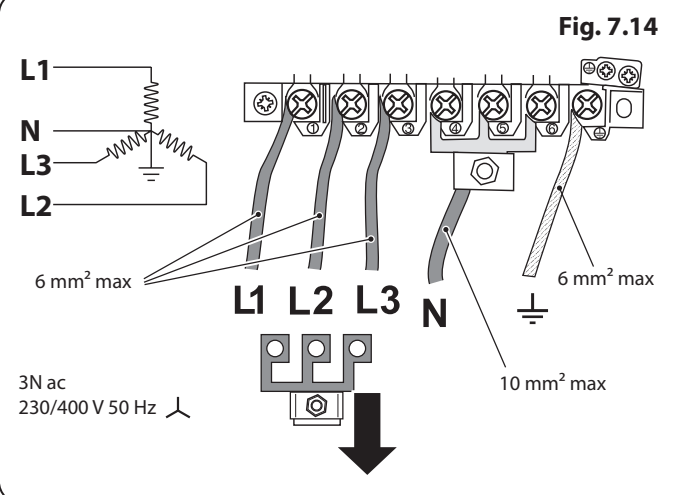
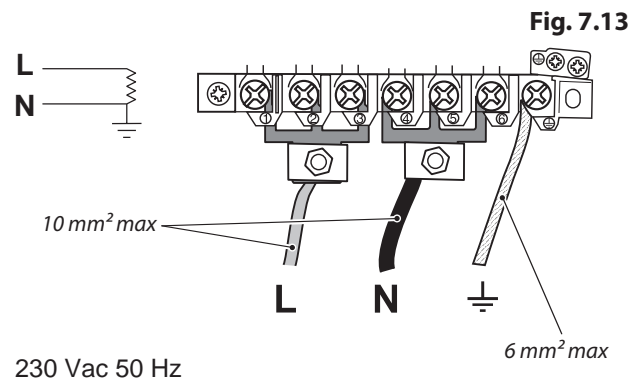

## INSTALLATION

Check the appliance is electrically safe and gas sound when you have finished.

Fig. 7.15

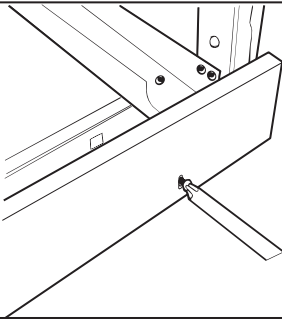

## Final checks

### Hotplate check

Check each burner in turn (refer to the 'Hotplate Burners' section at the front of the instructions).

### Oven check

Turn on the ovens. Check that the oven fans start to turn and that the ovens start to heat up.

Turn off the oven.

## Final fitting

### Fitting the plinth

Loosen the 3 screws along the front bottom edge of the cooker. Hook the central keyhole over the central screw. Twist and fit each end keyhole over their respective screws. Tighten the fixing screws (**Fig. 7.15**).

## Customer care

**Installer:** Please complete your details in this guide, inform the user how to operate the cooker and hand over the instructions.

Thank you.

## INSTALLATION

Check the appliance is electrically safe and gas sound when you have finished.

### Fitting the drawer

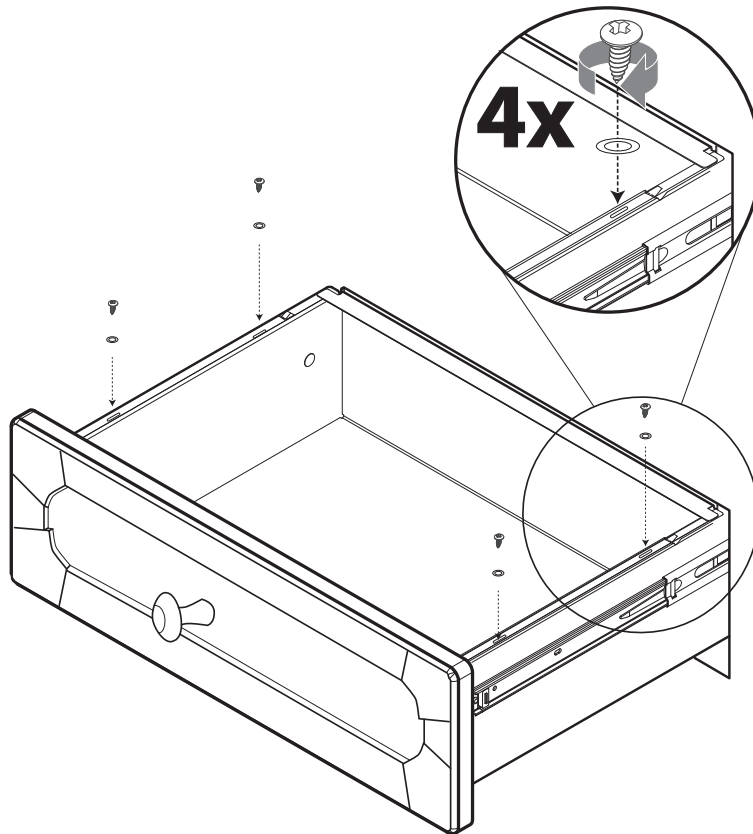

### Removing the drawer

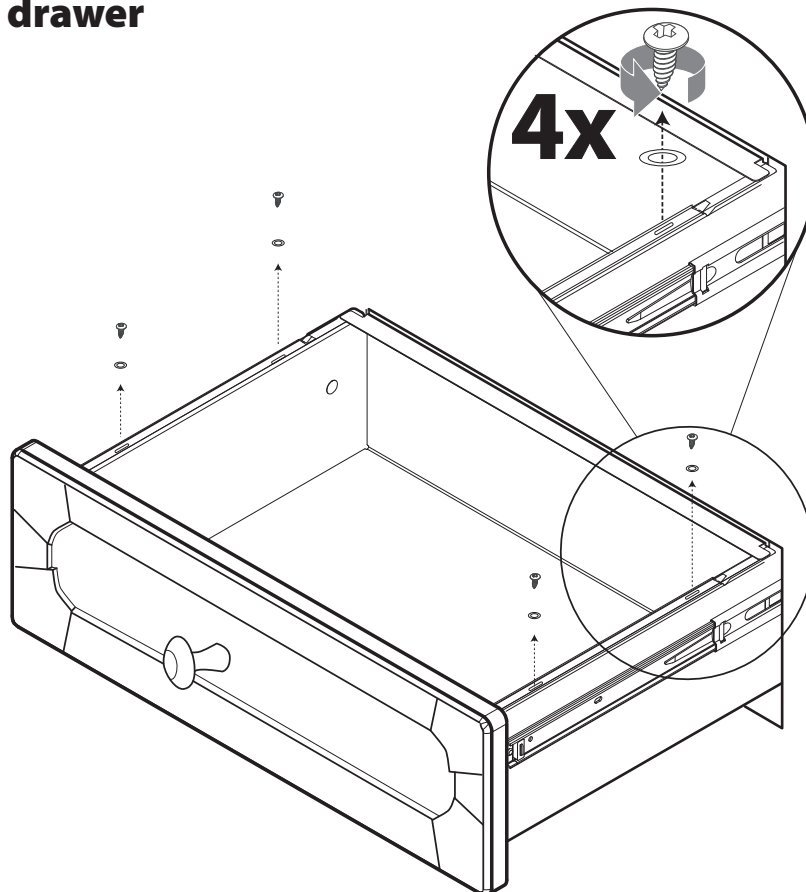

## 8. Circuit diagram

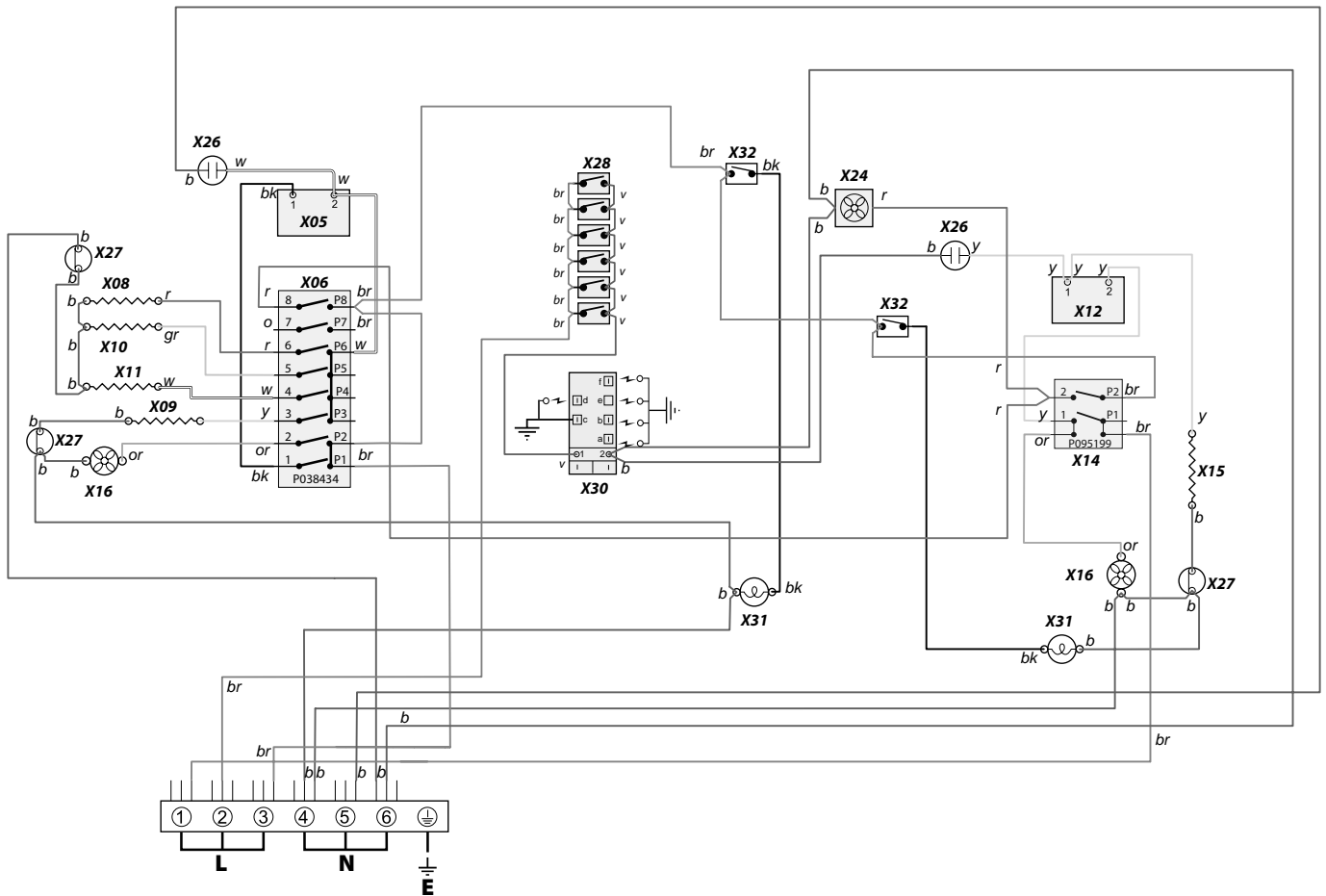

### Key

The connections shown in the circuit diagram are for single-phase. The ratings are for 230V 50 Hz. Component positions viewed from the front of the cooker

Code	Description	Code	Description
X05	Left-hand oven thermostat	X16	Oven fan
X06	Left-hand oven multifunction switch	X24	Cooling fan
X08	Left-hand oven base element	X26	Neon
X09	Left-hand oven fan element	X27	Thermal cut-out
X10	Left-hand oven top element (outer)	X28	Ignition switches
X11	Left-hand oven top element (inner)	X30	Spark generator
X12	Right-hand oven thermostat	X31	Oven light
X14	Right-hand oven front switch	X32	Oven light switch
X15	Right-hand oven fan element		

Code	Colour
b	Blue
br	Brown
bk	Black
or	Orange
r	Red
v	Violet
w	White
y	Yellow
g/y	Green/yellow
gr	Grey

## 9. Technical Data

**INSTALLER:** Please leave these instructions with the user.

**DATA BADGE LOCATION:** Cooker back, serial number repeater badge below oven door opening.

**COUNTRY OF DESTINATION:** GB, IE, FR, NL, DE, SE, IT, AT, CH, LU, BE.

### Gas Category & Pressure Settings

This appliance is supplied set for one of the gas categories listed in the table below, dependant on country of destination.

Category	Country	Natural Gas	L.P. Gas
Cat II <sub>2</sub> H3+	GB, IE	G20 20mbar	G30 butane 29mbar G31 propane 37mbar
Cat II <sub>2</sub> E3B/P Cat II <sub>2</sub> ELL3B/P	DE	G20 20mbar G25 20mbar	G30 butane 29mbar G31 propane 29mbar G30 butane 50mbar G31 propane 50mbar
Cat II <sub>2</sub> E+3+	FR, BE	G20 20/25mbar	G30 butane 29mbar G31 propane 37mbar
Cat II <sub>2</sub> H3B/P	SE	G20 20mbar	G30 butane 29mbar G31 propane 29mbar
Cat II <sub>2</sub> L3B/P	NL	G25 25mbar	G30 butane 29mbar G31 propane 29mbar

### Hotplate Ratings

See the data badge for information on the gas and pressure for which the appliance is set.

If a conversion is required follow the conversion instructions.

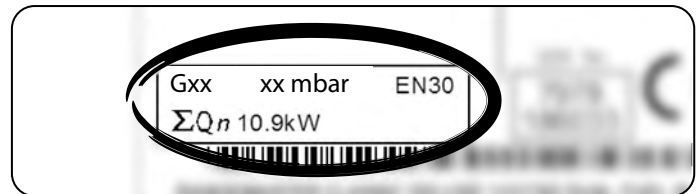

Hotplate	Bypass Screw*	Natural Gas G20 20 mb		L.P. Gas 29 / 37 mb	
			Injector		Injector
Centre burner	57	5.0 kW	165	5.0 kW (364g/h)	107
Large burner	40	3.0 kW	120	3.0 kW (218g/h)	82
Semi Rapide/ small	32	1.70 kW	95	1.70 kW (124g/h)	64
Hotplate	Bypass Screw*	Natural Gas G25 25 mb		L.P. Gas 29 mb	
			Injector		Injector
Centre burner	57	5.0 kW	163	5.0 kW (364g/h)	107
Large burner	40	3.0 kW	123	3.0 kW (218g/h)	82
Semi Rapide/ small	32	1.70 kW	96	1.70 kW (124g/h)	64
Hotplate	Bypass Screw*	Natural Gas G25 20 mb		L.P. Gas 50 mb	
			Injector		Injector
Centre burner	57	5.0 kW	173	5.0 kW (364g/h)	92
Large burner	40	3.0 kW	130	3.0 kW (218g/h)	71
Semi Rapide/ small	32	1.70 kW	102	1.70 kW (124g/h)	53



\* The valves in this cooker are fitted with adjustable bypass screws. If the appliance is supplied set for natural gas, the bypass screws will be unscrewed. For LPG conversion the bypass screws must be screwed all the way down.

If the appliance is supplied set for LPG, the bypass screws will be screwed all the way down. For Natural Gas conversion the bypass screws must be screwed out in accordance with the instruction in the conversion kit supplied.

## Connection

Electric	230/400V 50 Hz
----------	----------------

## Dimensions

Model	Continental Dual Fuel	
Overall height	minimum 912 mm	maximum 937 mm
Overall width	1092 mm	
Overall depth	600 mm excluding handles, 660 mm including handles	
Minimum height above the hotplate	650 mm	

### Hotplate energy saving tips

Use cookware with a flat base.

Use the correct size cookware.

Use cookware with a lid.

Minimise the amount of liquid or fat.

When liquid starts boiling, reduce the setting.

Consumption is based on G30.

### Oven energy saving tips

Cook meals together, if possible.

Keep the pre-heating time short.

Do not lengthen cooking time.

Do not open the oven door during the cooking period.

Do not forget to turn the appliance off at the end of cooking.

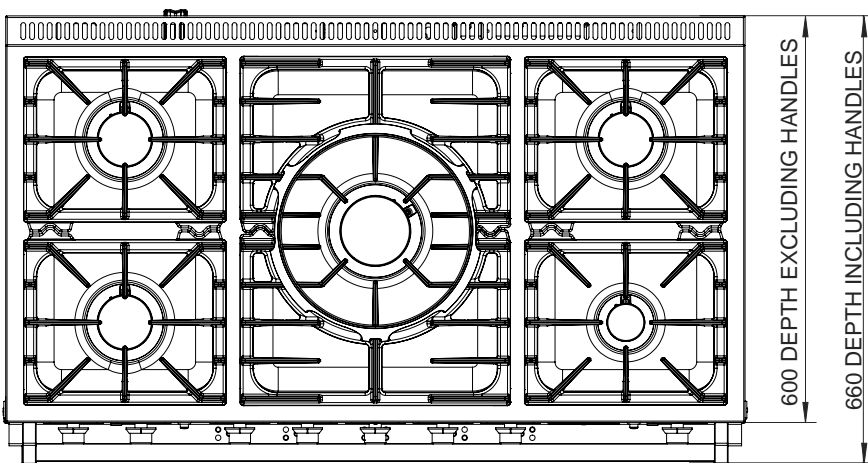
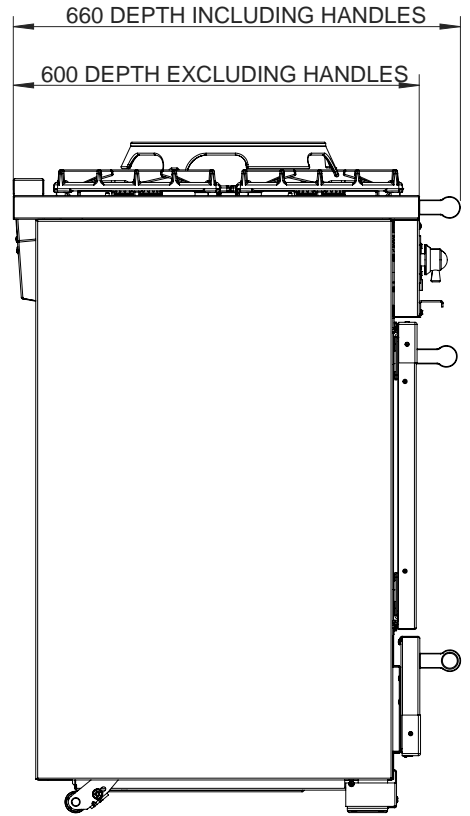
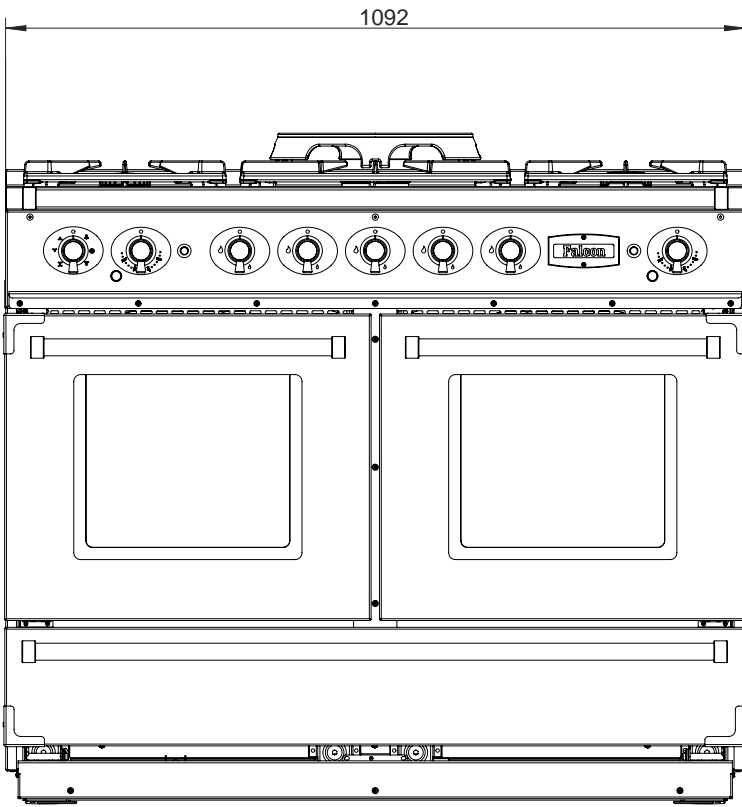

## English

### Hotplate efficiency data

Brand	Falcon
Model Identification	Continental
Size	1092
Type	Dual Fuel

Type of Hob	GAS
Number of gas burners	5
Auxiliary / Small Burner (EE gas burner)	-
Semi Rapide / Medium Burner (EE gas burner)	60.8%
Semi Rapide / Medium Burner (EE gas burner)	-
Rapide / Large Burner (EE gas burner)	58.5%
Rapide / Large Burner (EE gas burner)	58.5%
Rapide / Large Burner (EE gas burner)	58.5%
Ultra Rapide / large burner EEGas Burner (%)	55.4%
Wok (EE gas burner)	-
Wok (EE gas burner)	-
Hotplate EE gas hob (*)	58.3%

Information marked thus (\*) is not required with mixed fuel hobs

## Oven data

Brand	Falcon	
Model identification	1092 Continental	
Type of oven	Electric	
Mass	kg	146
Number of cavities	2	
<b>Left-hand Efficiency</b>		
Fuel type	Electric	
Cavity type	Multifunction	
Power - conventional	2.2	
Power - forced air convection	2.5	
Volume	Litres	79
Energy consumption (electricity) - conventional	kWh / cycle	1.01
Energy consumption (electricity) - forced air convection	kWh / cycle	0.88
Energy efficiency index - conventional	114	
Energy efficiency index - forced air convection	100	
Energy class	A	
<b>Right-hand Efficiency</b>		
Fuel type	Electric	
Cavity type	Fanned	
Power - conventional	-	
Power - forced air convection	2.5	
Volume	Litres	79
Energy consumption (electricity) - conventional	kWh / cycle	-
Energy consumption (electricity) - forced air convection	kWh / cycle	0.83
Energy efficiency index - conventional	-	
Energy efficiency index - forced air convection	94.4	
Energy class	A	

<b>Additional Information</b>		
The oven complies with EN 60350-1		
Maximum output @ 230V 50Hz		
Conventional	2.2 kW	
Multifunction	2.5 kW	
Multifunction (with Rapid Response)	-	
Forced Air Convection	2.5 kW	
Grill	-	
Slow Oven	-	
Bread Proving Drawer	-	

<b>Maximum total electrical load at 230 V</b> (approximate total including hob, oven lights, oven fan, etc.):	5.15 kW
---	---------

## NOTES

---

## NOTES

---

Clarence Street, Royal Leamington Spa,  
Warwickshire, CV31 2AD, England.  
[www.falconworld.com](http://www.falconworld.com)

CE  
UK  
RA